

HAWK 8000 Controller

MOUNTING INSTRUCTIONS

E Keep these instructions together with the device or with the equipment documentation!	F Cette instruction est à conserver avec le contrôleur ou avec la documentation de l'installation !	P Guarde estas instruções junto do regulador ou junto da documentação da instalação!
D Diese Anleitung ist beim Gerät oder in der Anlagendokumentation aufzubewahren!	I Queste istruzioni devono essere conservate insieme al lettore o con la documentazione dell'impianto!	S Denna instruktion skall förvaras tillsammans med regler eller anläggningsdokumentationen!
DK Opbevar denne vejledning sammen med regler eller med anlægsdokumentationen!	N Denne vejledningen skal opbevares sammen med regler eller anlægsdokumentationen!	FI Tätä ohjetta tulee säilyttää laitteen läheisyydessä tai yhdessä muiden dokumenttien kanssa!
ES Conserve estas instrucciones con el recalar o con la documentación de la instalación.	NL Deze handleiding moet bij de regelaar, of met de documentatie van de installatie worden bewaard!	PL Instrukcję obsługi należy przechowywać przy urządzeniu albo w dokumentacji technicznej.

0A: INFO!

HAWK 8000 CONTROLLER
MOUNTING INSTR. (MU1Z-1016GE51)

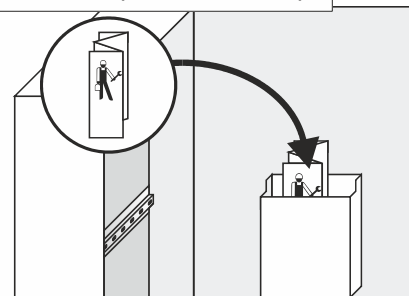

i → www.centraline.com
HAWK 8000 CONTROLLER...
● PRODUCT DATA (EN0Z-1016GE51)
● INSTALLATION & COMM. INSTRUCTIONS (EN1Z-1016GE51)
● GENERAL SECURITY BEST PRACTICES (EN0Z-1017GE51)

i → www.tridium.com/en/resources/library
HON-NXEM-xxx EXPANSION MODULES
● INSTALLATION INSTRUCTIONS (MU1Z-1031GE51)
● END USER LICENSE AGREEMENT (EULA)

0B: INFO!

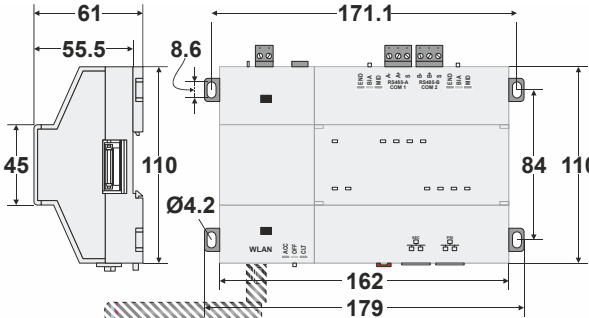

LICENSING INFORMATION
TO OBTAIN PURCHASED LICENSE, GO TO www.niagara-central.com
LOG IN, ENTER YOUR **HOST-ID** AND THEN DOWNLOAD THE LICENSE.



NETWORK SECURITY

Honeywell hereby expressly states that the HAWK 8000 is not inherently protected against cyber attacks from the Internet and that it is therefore intended solely for use in private, protected networks. For more information, see also section "Network Security" of **HAWK 8000 Controller – Product Data (EN0Z-1016GE51)** and **General Security Best Practices – Security Document (EN0Z-1017GE51)**.

For fixes, guidance, patches, etc., see also:

<https://www.tridium.com/en/support/products/technical-bulletins>

1A. DIN RAIL MOUNTING

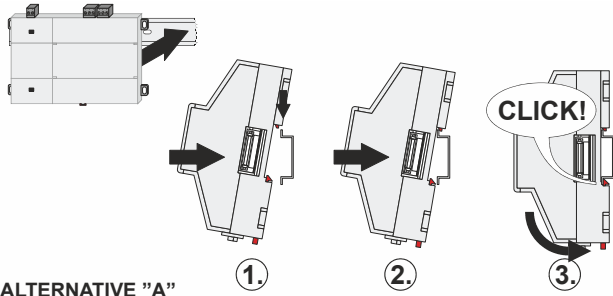

ALTERNATIVE "A"

ALTERNATIVE "B"

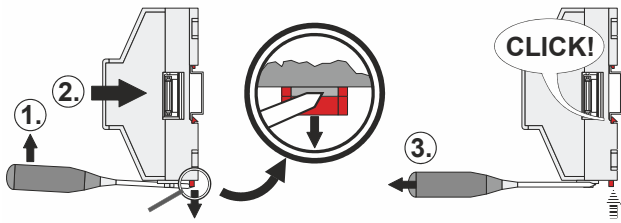

1B. DIN RAIL DISMOUNTING

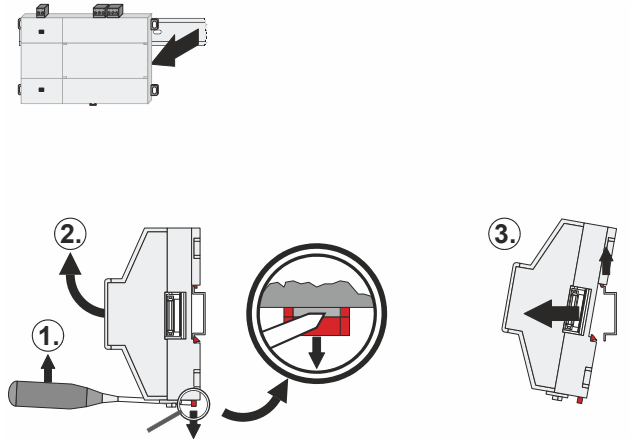

2. WALL MOUNTING

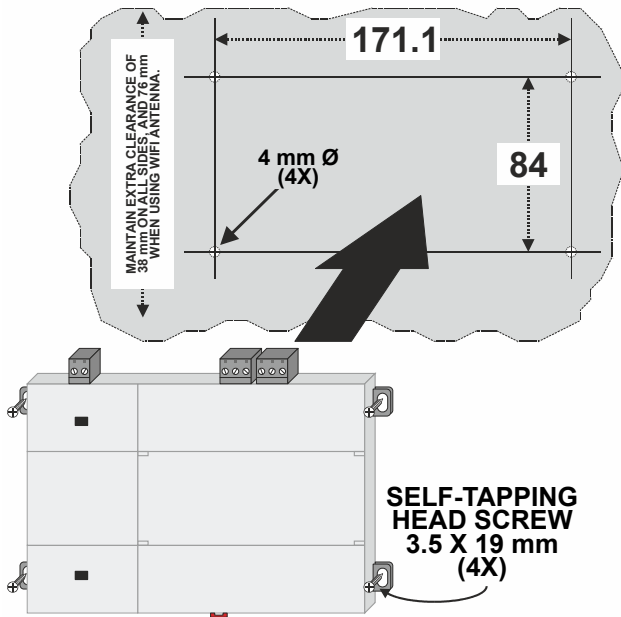

3A. EXPANSION MODULES

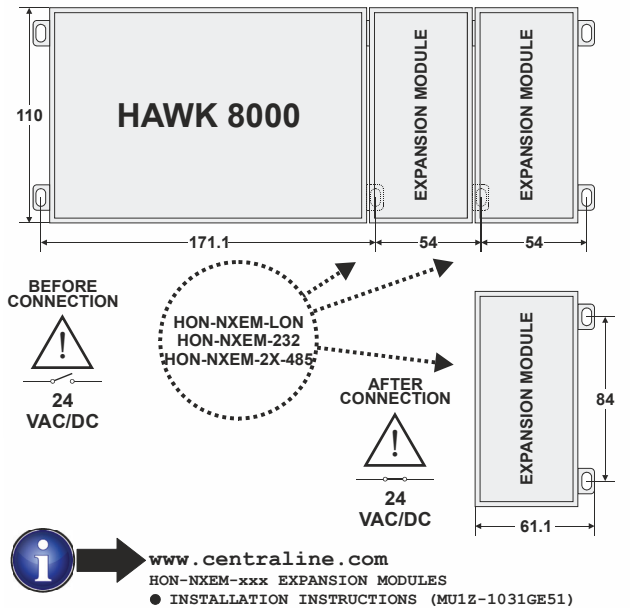

3B. EXPANSION MODULES



MAX. 3 EXPANSION MODULES



MAX. 4 EXPANSION MODULES

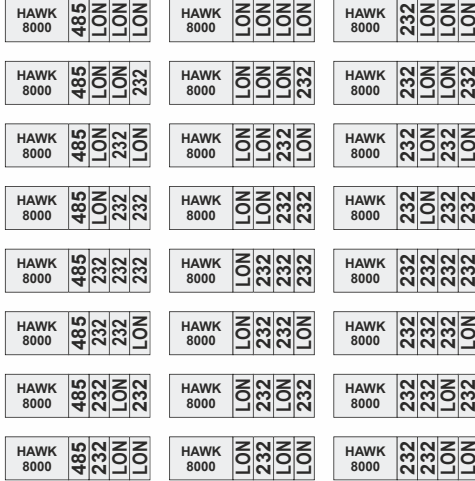

4. WIFI ANTENNA, SD MICROCARD

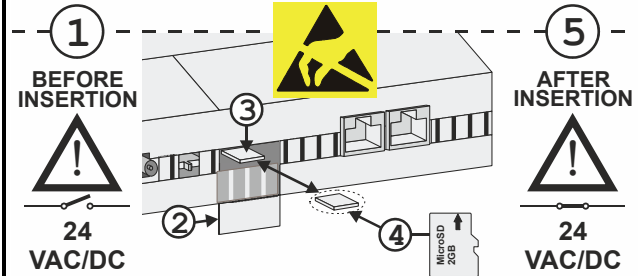
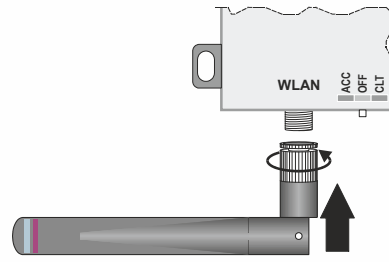

5A. WIRING POWER

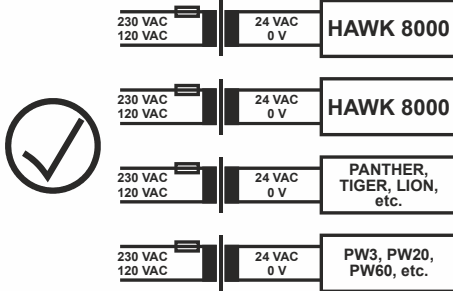
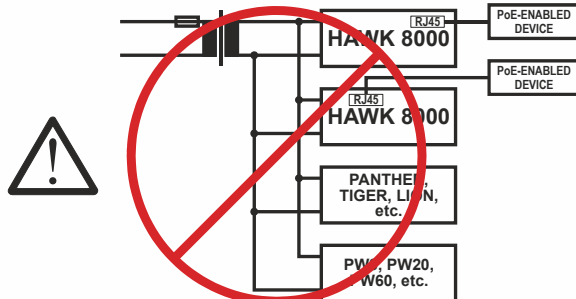

5B. EARTH GROUND and POWER

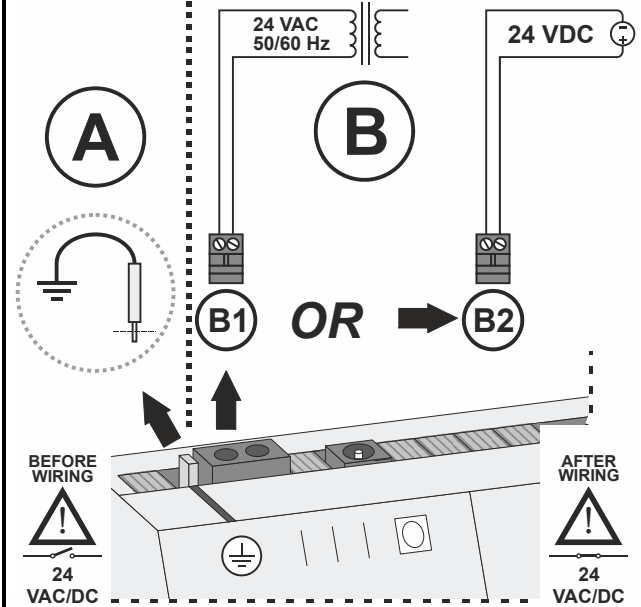

SPECIFICATIONS OF CONTROLLER

Power supply	24 VAC ± 10%, 50/60 Hz 24 VDC ± 10%
Ambient operating temperature	-20 ... +60 °C
Storage temperature	-40 ... +85 °C
Humidity	5 ... 95% r.h. non-condensing
Dimensions	See pictures 0B, 3A.
Degree of protection	IP20 (mounted outside panels) IP30 (mounted inside panels)

CABLE SPECIFICATIONS

plug gauge	0.2 ... 1.50 mm ² (18...22 AWG)
solid conductor H05(07) V-K	
stranded conductor H05(07) V-K	
stranded conductor with wire end ferrules (w/o plastic collar)	

WEEE DIRECTIVE

WEEE: Waste Electrical and Electr. Equipment Directive	
	<ul style="list-style-type: none"> At the end of the product life, dispose of the packaging and product in an appropriate recycling center. Do not dispose of the device with the usual domestic refuse. Do not burn the device.

COMPLIANCE WITH DIRECTIVE 2014/53/EU

E:	Honeywell hereby declares that the radio equipment types CLNXSERIES8, CLNXHAWK8, and CLNXSERIES8W02, CLNXHAWK8W02 are in compliance with Directive 2014/53/EU. The full text of the EU declaration of conformity is available at the following Internet address: http://products.centraline.com/en/
D:	Hiermit erklärt Honeywell, dass der Funkanlagentyp CLNXSERIES8, CLNXHAWK8, CLNXSERIES8W02 und CLNXHAWK8W02 der Richtlinie 2014/53/EU entspricht. Der vollständige Text der EU-Konformitätserklärung ist unter der folgenden Internetadresse verfügbar: http://products.centraline.com/en/
F:	Le soussigné, Honeywell, déclare que l'équipement radio-électrique du type CLNXSERIES8, CLNXHAWK8, CLNXSERIES8W02 et CLNXHAWK8W02 est conforme à la directive 2014/53/UE. Le texte complet de la déclaration UE de conformité est disponible à l'adresse internet suivante: http://products.centraline.com/en/

STANDARDS, APPROVALS, ETC.

UL 916, Energy Management Equipment – Edition 4
CE: 2014/53/EU RED, 2011/65/EU RoHs
FCC Part 15, Class B, Subpart C, Subpart E
C-UL listed to Canadian Standards Assoc. (CSA) C22.2 No. 205-M1983 "Signal Equipment"
Ethernet: IEEE802.3
Purpose of the device is: multifunctional non-safety control intended for HVAC in home (residential, commercial, and light-industrial) environments
NOTE: Keep AC mains supply/load cables separate from signal wiring!

CHINA EEP HAZARDOUS SUBSTANCE INFO

 RESTRICTED MATERIAL ABOVE THRESHOLD

部件名称 Assembly Name	有害物质 Hazardous Substances					
	铅 (Pb)	汞 (Hg)	镉 (Cd)	六价铬 (Cr6+)	多溴联苯 (PBB)	多溴二苯醚 (PBDE)
PWB组件 PWB Assemblies	X	O	O	O	O	O
本表格依据 SJ/T 11364 的规定编制。 This table is prepared in accordance with the provisions of SJ/T 11364.						
O: 表示该有害物质在该部件所有均质材料中的含量均在 GB/T 26572 规定的限量要求以下 Indicates that said hazardous substance contained in all of the homogeneous materials for this part is below the limit requirement of GB/T 26572.						
X: 表示该有害物质至少在该部件的某一均质材料中的含量超出 GB/T 26572 规定的限量要求 Indicates that said hazardous substance contained in all of the homogeneous materials for this part is above the limit requirement of GB/T 26572.						
未列入表内的其他部件· 皆不含任何超出限量要求的限制使用物质 All other components not listed in the table do not contain restricted substances above the threshold level.						
电子电气产品的环保使用期限依据SJ/T11388 标准的规定确定。 The EPUP value of EEP is defined according to SJ/T 11388 standard.						

Manufactured for and on behalf of the Environmental & Energy Solutions Division of Honeywell Technologies Sàrl, Rolle, Z.A. La Pièce 16, Switzerland by its Authorized Representative:

CentraLine Honeywell GmbH Böblinger Strasse 17 71101 Schönaich, Germany Phone +49 (0) 7031 637 845 Fax +49 (0) 7031 637 740 info@centraline.com www.centraline.com	 by Honeywell
Subject to change without notice MU1Z-1016GE51 R0517A	