

IRM

Application Guide





APPLICATION GUIDE

Software License Advisory

This document supports software that is proprietary to Honeywell GmbH, Honeywell Control Systems Ltd. and/or to third party software vendors. Before software delivery, the end user must execute a software license agreement that governs software use. Software license agreement provisions include limiting use of the software to equipment furnished, limiting copying, preserving confidentiality, and prohibiting transfer to a third party. Disclosure, use, or reproduction beyond that permitted in the license agreement is prohibited.

Trademark Information

Centraline and 'close to you' are trademarks of Honeywell Inc.

Windows 7 and Windows 8 and Word are registered trademarks of Microsoft Corp.

CONTENTS

VERSIONING	8
	New Application Functions	8
REVISION HISTORY	8
INTRODUCTION	9
	Application Overview	10
APPLICATION COMPONENTS AND FUNCTIONS	11
	Fan Coil Unit (FCU)	11
	Basic Features	12
	Advanced Features	13
	Sequence Logic, Conditions and Overrides	13
	Water Cooling	13
	Water Heating	14
	DX-Cooling Coils	15
	E-Heating Coils	16
	Fan	17
	Ceiling	19
	Basic Features	21
	Advanced Features	22
	Sequence Logic, Conditions and Overrides	22
	Ceiling Cooling Stage	22
	Ceiling Heating Stage	23
	Switchover Piping Configuration	24
	Radiator	26
	Basic Features	27
	Advanced Features	27
	Sequence Logic, Conditions and Overrides	27
	Underfloor Heating	29
	Advanced Features	30
	Sequence Logic, Conditions and Overrides	30
	Intake Air	32
	Basic Features	32
	Advanced Features	33
	Cooling	33
	Sequence Logic, Conditions and Overrides	34
COMMON SETTINGS	35
	Space Temperature Setpoints	35
	Occupancy Mode	36
	Limit Control	36
	Dewpoint	36
	Temperature Protection	37
	Night Purge	37
EFFECTIVE CONTROL MODE	39
	Effective Space Setpoint	40
	Effective Setpoint Mode	40
CONTROL STRATEGY	41
	Space Temperature Control	41
	Sequence Configuration	41
	Space Temperature with Limit Control	42
	Space Temperature with Low Limit Control	42
	Space Temperature with High Limit Control	43
	Space Temperature as Cascade Control	43
FANS	47
	Types	47
	Multi-Speed Fan	47
	Multi-speed Fan Wiring	47
	Multi-Speed Fan Settings	48
	Variable-Speed Fan	49
	Fan Control Strategy	49
	Occupancy Optimization	51
	Fan Override Settings	51

WALL MODULES	52
Conventional Wall Modules.....		52
Wall Module Functions and Types.....		52
Space Temperature Setpoint Adjustments.....		52
Relative Setpoint Adjustment.....		52
Absolute Setpoint Adjustment.....		53
Delays and Reset.....		53
Demand Limit Control.....		53
Summer Compensation.....		54
LED Indication Modes.....		54
On-Off / Fanspeed Selection / Button Adjustments.....		55
Bus-Capable Syk Wall Modules.....		55
Wall Module Functions and Types.....		55
Setpoint Adjustments.....		56
Delays and Reset.....		56
OCCUPANCY MODES	57
Occupancy Mode Control.....		57
Sensor Switching Configuration.....		57
Effective Occupancy Mode.....		58
BACnet Occupancy Override.....		60
FREE INPUTS AND OUTPUTS	61
Free Inputs.....		61
Free Outputs.....		62
Room Controller Overview.....		65
Features.....		65
Overview of Terminals and Functions.....		66
SENSORS	70
Air Quality Sensor.....		70
Ceiling Cold Water Temperature Sensor.....		70
FCU Discharge Temperature Sensor.....		70
Cool / Heat Changeover Temperature.....		71
Humidity Sensor.....		71
Intake Air Temperature Sensor.....		72
Radiator Radiation Temperature Sensor.....		72
Space Temperature Sensor.....		72
Underfloor Heating Temperature Sensor.....		73
Airflow Sensor.....		73
Card Reader.....		74
Condensation.....		74
Door Contact.....		74
Drip-Pan Contact.....		75
Occupancy Sensor.....		75
Window Contact.....		75
ACTUATORS	76
Actuator Types.....		76
Analog 0/2..10 V Actuator.....		76
Floating Actuator.....		76
PWM Actuators.....		77
Staged Actuators.....		77
On/Off Actuators.....		78
6-Way MID Valve.....		78
MASTER-SLAVE CONTROLLERS	80
System Architecture.....		80
Functional Description.....		80
Common Temperature Control.....		80
Communication and Value Aggregation.....		81
Communication.....		82
Value Aggregation.....		82
Control Output Processing.....		84
FIRE MODE	86
ALARMING	87
Sensor Failure Behavior.....		88
ACCESS IRM CONTROLLER PARAMETERS		90

Load Parameters	90
Change Parameters	92
Binding of Parameters	94
Updating Parameters	94

APPENDIX

.....	96
BACnet Variables Overview	96
BACnet Information	104
Troubleshooting	104

VERSIONING

This application guide is applicable to the **IRM_H_0005** application.

NEW APPLICATION FUNCTIONS

The application IRM_H_0005 replaces application IRM_H_0004. It is fully backwards compatible.

The following application changes are newly added.

- The Cascade control, the fan adjustment, and the fan control are improved.
- FCU 2-pipe Cooling + Heating + E-Heating supports E-Heating with staged output for relay and triac

REVISION HISTORY

Based on the changes and new functions of the **IRM_H_0005** application in comparison to the **IRM_H_0004** application, the following changes are made to this document in comparison to the previous version:

Text addition in section:

Space Temperature as Cascade Control, p. 43 et seq.

Revision in section:

New Application Functions, p. 853

Space Temperature as Cascade Control, p. 43 et seq.

Text replacement in section:

New Application Functions, p. 853

revision history, p. 8

System Architecture, p. 80, 0004 replaced by 0005

Updating Parameters, p. 94, 0004 replaced by 0005

Term replacement in whole document and all graphics:

Discharge air temperature replaced by FCU Discharge Temperature

Revised table in section:

BACnet Variables Overview, pgs 96 103 Table 15: BACnet Objects Parameter List

Figure addition in section:

Space Temperature as Cascade Control, p. 43 et seq.

Figure changed or replaced in section:

Application Overview, p. 10, Discharge air temperature replaced by FCU Discharge Temperature in Sensors

Fan Coil Unit (FCU), p. 11, Discharge air temperature replaced by FCU Discharge Temperature

Fan Control Strategy, p. 49

INTRODUCTION

The IRM (integrated room management) system provides temperature and air-conditioning control for individual rooms based on the BACnet MS/TP bus. For one room, the system typically includes at least the following:

- 1 room controller (incl. a configurable standard application)
- 1 plant controller (including scheduler, sharing hot/cold water info, night purge, outside air temp, etc.)
- 1 wall module (incl. a temperature sensor)
- 1 BACnet router
- control equipment and corresponding functions in the room controller:
fan coil unit, ceiling, underfloor heating, radiator heating, and/or intake air
- sensors according to the configured application (optional)
- actuators and valves according to the configured application

A room controller includes the configurable standard application supporting fan coil unit, ceiling, underfloor heating, radiator heating as well as intake air applications. It is possible to handle a mix of these applications in one controller, that is, the applications can be used alone or in any kind of combination.

One controller with its configurable application controls one room temperature. Controllers can be used in a master-slave arrangement. The configured application will be quickly commissioned using the RoomUp Android app.

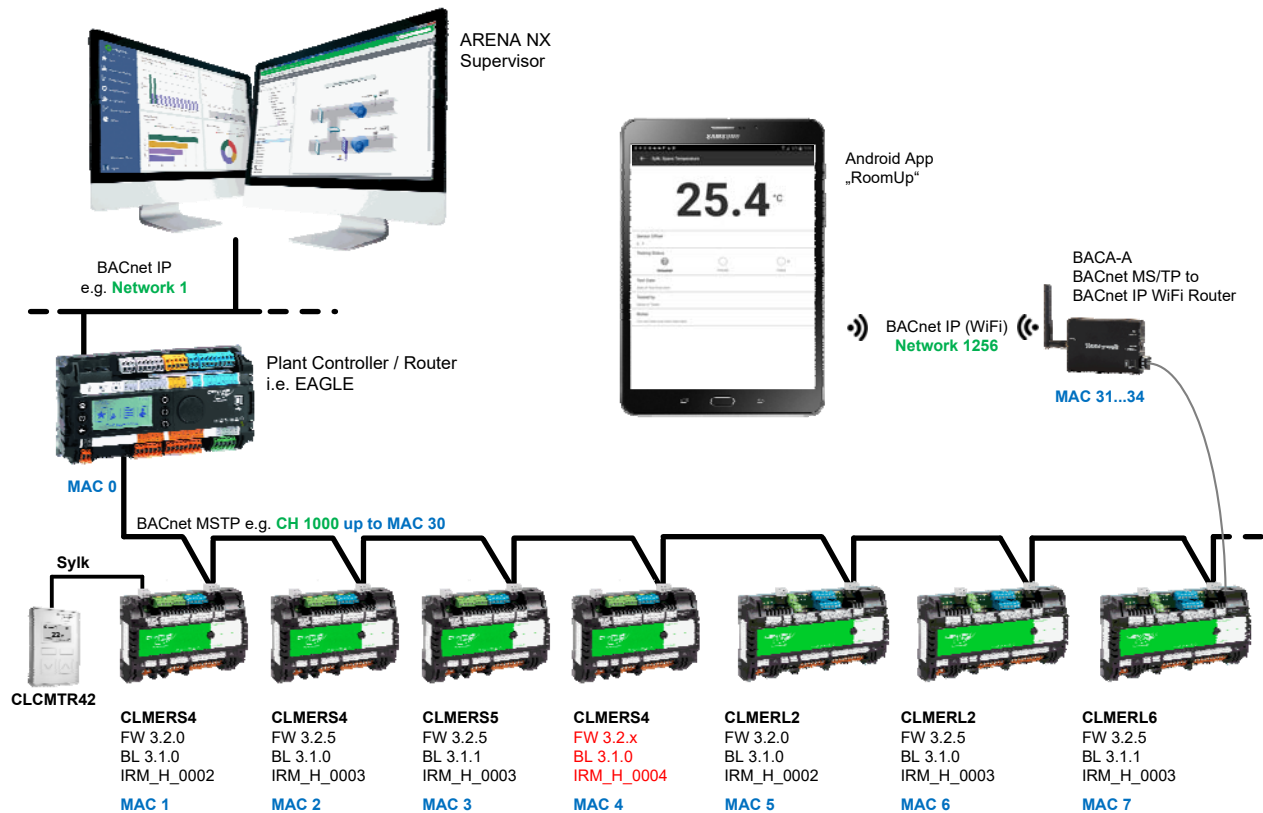

Fig. 1. System Architecture

Application Overview

The standard application supports 5 main types of applications which can be enabled separately and configured individually. The physical inputs and outputs available on the selected controller model will determine which functions can be selected. Multiple functions can be enabled at the same time up to the limit of the physical hardware inputs and outputs available in the controller model selected. The application running in the controller supports conventional wall modules and bus-capable Sylk wall modules and sensor values via BACnet. All controller models are delivered with the configurable standard application. The standard application provides the following functions:

Fan Coil Unit	Ceiling	Intake Air	Radiator Heating	Underfloor Heating
Equipment Configurations				
Chilled Water Cooling	Cooling	Cooling	Heating	Heating
DX-Cooling	Heating	Intake Air Damper		
Hot Water Heating				
Electric Heating				
2-Pipe Changeover or 4-Pipe System 6-Way MID Valve	2-Pipe Changeover, 4-Pipe System, or 6-Way MID Valve			
Control Strategy Modes				
Room Temperature Control	Room Temperature Control	Room Temperature Control	Room Temperature Control	Room Temperature Control
Cascade Temperature Control		Room Temperature Control with Low Limit Cooling	Room Temperature Control with Low Limit Heating	Room Temperature Control with High Limit Heating
Room Temperature Control with Low Limits for Heating and Cooling		Air Quality and Cooling Control (optional with Low Limit Cooling)		
1,- 2-, 3-Speed Fan*				
Variable-Speed Fan**		Air Quality Control only		

*/** The fan speed can be independent of heat and cooling sequences.

The following schematic gives an overview of the supported applications:

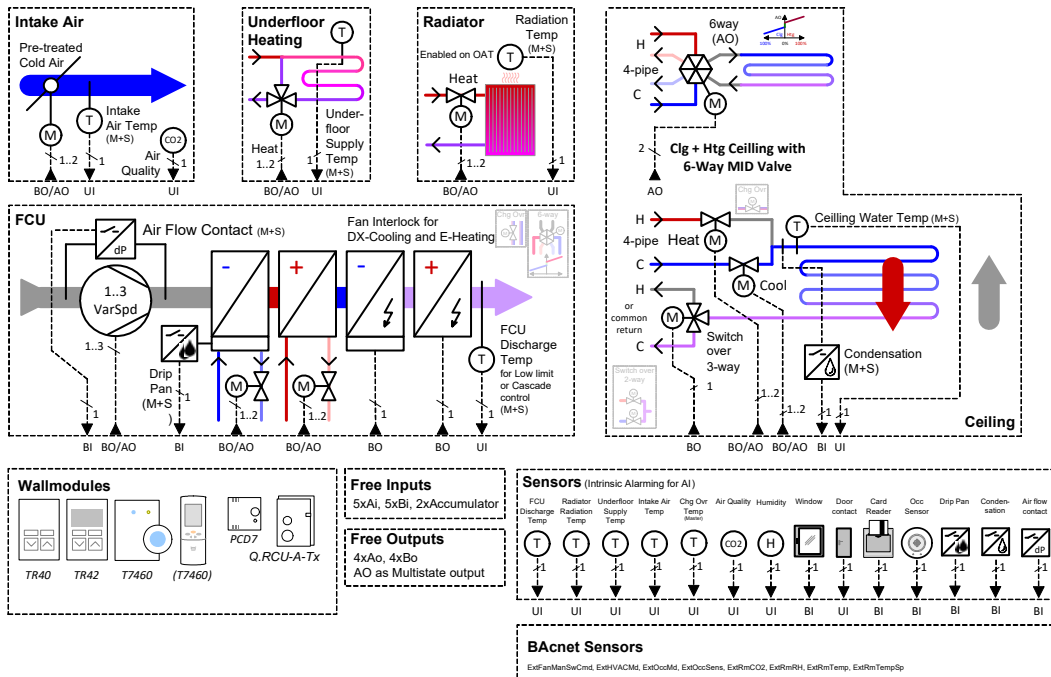

Fig. 2. Application Overview

APPLICATION COMPONENTS AND FUNCTIONS

Fan Coil Unit (FCU)

FCU systems control the space temperature in a given room by regulating the heating and/or cooling equipment which control the temperature of that space and the fan which controls air flow. Reheat coils are often included at the fan coil unit. In addition, a discharge temperature sensor can be applied in order to control the discharge temperature.

The room controlled by the room controllers will typically use a wall module with a temperature sensor for space temperature measurement, setpoint selection, occupancy/unoccupancy override, and heat/cool mode selection.

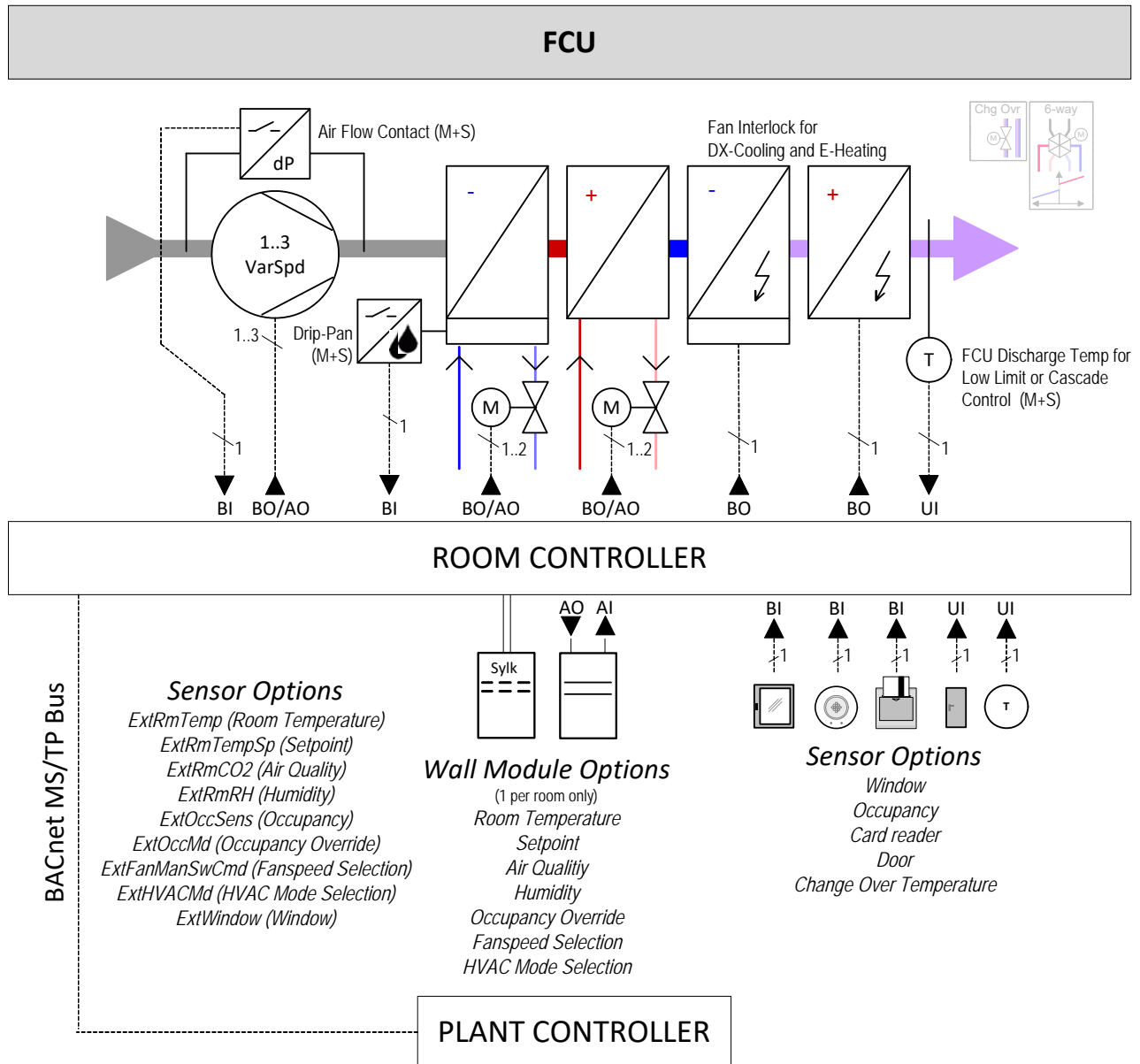

Fig. 3. Fan Coil Unit control application

Basic Features

The FCU application type supports:

Inputs

- Assigned via wall module and explicit sensor selection (see section “Advanced Features“, p. 13)

Equipment Configurations

- water cooling and water heating (2-pipe or 4-pipe or 4-pipe with 6-way valve)
- E-heating and DX-cooling (incl. fan interlock)
- 1-, 2-, and 3-speed, or variable-speed fan (incl. fan override and optimization for occupancy mode) dependent or independent from heat/cool sequences

For detailed information on equipment configuration, please refer to the section “Sequence Logic, Conditions and Overrides“, p. 13.

Control Strategy Modes

- space temperature control
- space temperature with low limit control (heating and/or cooling)
- space temperature as cascade control
- fan can be controlled:
 - depending on cooling / heating sequences output signal
 - by a separate PID function

For detailed information on control strategy, please refer to the section “Control Strategy“, p. 41.

Control Sequence Configuration

- Start and end levels for cooling, heating and fan

For detailed information on control sequence configuration, please refer to the section “Sequence Configuration“, p. 41.

Outputs

- 0/2 .. 10 V
- Floating
- PWM
- 1-Stage
- 2-Stage parallel or serial
- 3-Stage

For detailed information on outputs, please refer to the sections “Actuators“, p. 76 and “Free inputs and outputs“, p. 61.

FCU Equipment Combinations

The following FCU equipment combinations are possible:

Cooling	Heating	DX-Cooling	E-Heating	4-Pipe, or 2-Pipe Changeover System	2-Pipe System
X	X	X	X	X	-
X	X	X		X	-
X	X		X	X	-
X	X			X	-
X		X	X	-	X
X		X		-	X
X			X	-	X
X				-	X
	X	X	X	-	X
	X	X		-	X
	X		X	-	X
	X			-	X
		X	X	-	-
		X		-	-
			X	-	-

Advanced Features

Additionally, the following functions can be selected for the FCU application:

- Window contact
- Frost protection
- Overheat protection
- Drip-pan protection
- Night purge
- Airflow sensor
- Fan interlock (DX-cooling and E-heating only)
- Fan overrun time
- Fan start and stop levels and min. and max. speeds for heating and cooling

For detailed information on the settings of the advanced functions, please refer to the section “Sequence Logic, Conditions and Overrides”, p. 13. and the following sections:

- Window contact: “Window Contact”, p. 75
- Airflow sensor: “Airflow Sensor”, p. 73
- Drip-pan alarming: “Drip-Pan Contact”, p. 75
- Frost and overheat protection: “Temperature Protection”, p. 37
- Night purge: “Night Purge”, p. 37
- Fan interlock
- Fan overrun time
- Fan start and stop levels and min. and max. speeds for heating and cooling

Sequence Logic, Conditions and Overrides

Water Cooling

Whenever FCU cooling is selected, the cooling coil modulates in parallel with other cooling sequences based on the cooling demand. The chilled water cooling coil can be configured for 2-pipe changeover or 4-pipe control.

Sequence Logic

The following schematic shows the logic for the FCU cooling stage (master-slave behavior included). For a general description of a sequence logic in master-slave configuration, please refer to section “Master-Slave Controllers”, p. 80.

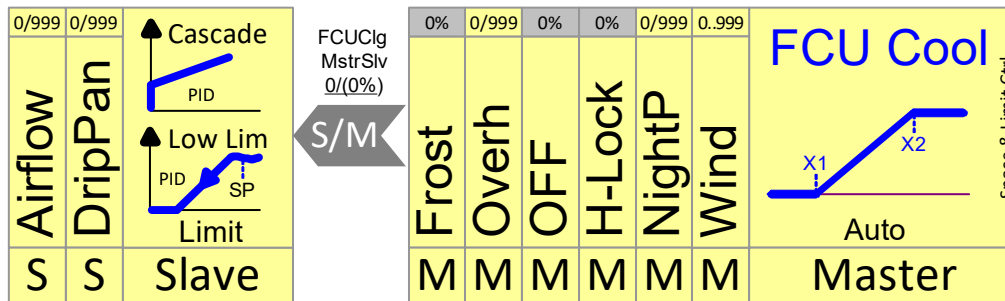

Conditions and Overrides

The cooling signal can be overridden in the following ways:

If... condition If ... configured	Then Override / Action for Cooling coil is...	Master (M) Slave (S)	Priority
Effective Control Mode	If the mode is not cooling, cooling coil is closed	M	
Window contact	If window is open, cooling coil is set to configurable position or the window contact can be ignored	M	
Night purge	It can be configured whether the cooling coil ignores Night Purge or it closes to 0%.	M	
H-Lock	If the setpoint is in heating mode, the cooling signal is set to 0 %	M	
OFF	If OFF selected on wall module, cooling coil is closed (= %)	M	
Overheat	If overheat condition is true, cooling coil is set to fixed position (= %) or can be ignored	M	
Frost	If frost condition is true, cooling coil is closed (= %) or can be ignored	M	
Drip-pan	If drip-pan alarm is activated, cooling coil is set to fixed position (= %) or can be ignored	M+S	
Airflow contact	If fan command is active and airflow is not confirmed, cooling coil is set to fixed position (= %) or can be ignored. The fixed level is maintained for a predefined time period after airflow has been established.	M+S	

NOTE: Balancing is triggered via RoomUp bulk command. A bulk command allows you to open a selectable amount of actuators as one bulk operation. The bulk command is a manual override via BACnet to the priority 8 of the corresponding BACnet object. Please make sure to relinquish the manual overrides in order to allow the controller to start with automatic control again. During balancing, the cooling coil is in a fully open or closed state (configurable in RoomUp) irrespective of other settings. During frost, cooling is closed for all cooling sequences and vice a versa for heating (over heat).

Water Heating

Whenever FCU heating is selected, the heating coil modulates in parallel with other heating sequences based on the heating demand from the selected temperature control type. The hot water heating coil is configured for 2 - pipe changeover or 4-pipe control.

Sequence Logic

The following schematic shows the logic for the FCU Heating stage (master-slave behavior included). For a general description of a sequence logic in master-slave configuration, please refer to section "Master-Slave Controllers", p. 80.

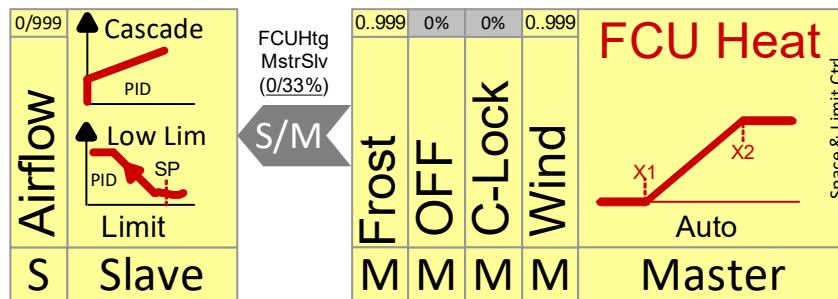

Conditions and Overrides

The heating signal can be overridden in the following ways:

If ... condition If ... configured	Then Override / Action for Heating coil is...	Master (M) Slave (S)	Priority
Effective Control Mode	If the mode is not heating, heating coil is closed	M	<p>low</p> <p>high</p>
Window contact	If window is open, heating coil is set to configurable position or the window contact can be ignored	M	
C-Lock	If the setpoint is in cooling mode, the heating signal is set to 0 %	M	
OFF	If OFF selected on wall module, heating coil is closed (=0%)	M	
Frost	If frost condition is true, heating coil is opened (=100 %) or can be ignored	M	
Airflow contact	If fan command is active and airflow is not confirmed, heating coil is set to fixed position (= %) or can be ignored. The fixed level is maintained for a predefined time period after airflow has been established	M+S	

DX-Cooling Coils

Whenever FCU DX-Cooling is selected, the DX-Cooling coil runs in conjunction with other cooling sequences based on the cooling demand from the selected temperature control type. The DX-Cooling signal is represented as a percentage and the output are staged on this percentage via pre-configured thresholds, hysteresis and time delays.

Fan Interlock

The DX cooling stage is only enabled if the fan is already running. A time delay can be configured between fan = On and valve opening = On.

Sequence Logic

The following schematic shows the logic for the FCU DX-Cooling stage (master-slave behavior included). For a general description of a sequence logic in master-slave configuration, please refer to section "Master-Slave Controllers", p. 80.

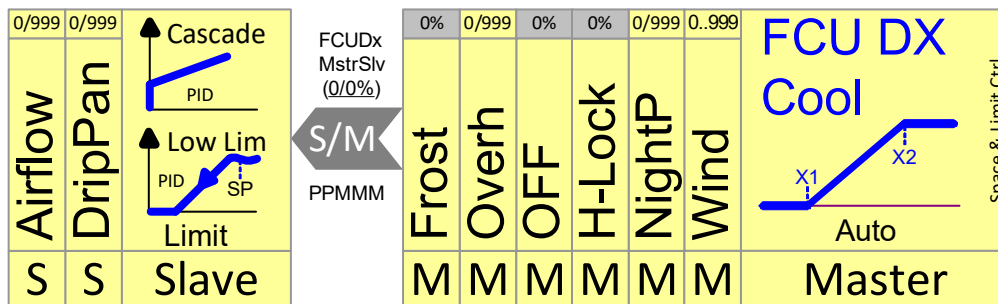

Conditions and Overrides

The DX-cooling signal can be overridden in the following ways:

If ... condition If ... configured	Then Override / Action for Cooling coil is...	Master (M) Slave (S)	Priority
Effective Control Mode	If the mode is not cooling, cooling coil is closed	M	
Window contact	If window is open, cooling coil is set to set to configurable position or the window contact can be ignored	M	
Night purge	It can be configured whether the cooling coil ignores Night Purge or it closes to 0%.	M	
H-Lock	If the setpoint is in heating mode, the cooling signal is set to 0 %	M	
OFF	If OFF selected on wall module, cooling coil is closed (= %)	M	
Overheat	If overheat condition is true, cooling coil is set to fixed position (= %) or can be ignored	M	
Frost	If frost condition is true, cooling coil is closed (= %) or can be ignored	M	
Drip-pan	If drip-pan alarm is activated, cooling coil is set to fixed position (= %) or can be ignored	M+S	
Airflow contact	If fan command is active and airflow is not confirmed, dx cooling coil is set to fixed position (= %) or can be ignored. The fixed level is maintained for a predefined time period after airflow has been established	M+S	

E-Heating Coils

Whenever FCU E-Heating is selected, the electrical heating coil runs in conjunction with other heating sequences based on the heating demand from the selected temperature control type. The electrical heating signal will be represented as a percentage and the outputs are staged on this percentage via pre-configured thresholds, hysteresis and time delays.

Fan Interlock:

The electrical heating stage is only enabled if the fan is already running. A time delay can be configured between fan = On and valve opening = On.

Sequence Logic

The following schematic shows the logic for the FCU E-Heating stage (master-slave behavior included). For a general description of a sequence logic in master-slave configuration, please refer to section "Master-Slave Controllers", p. 80.

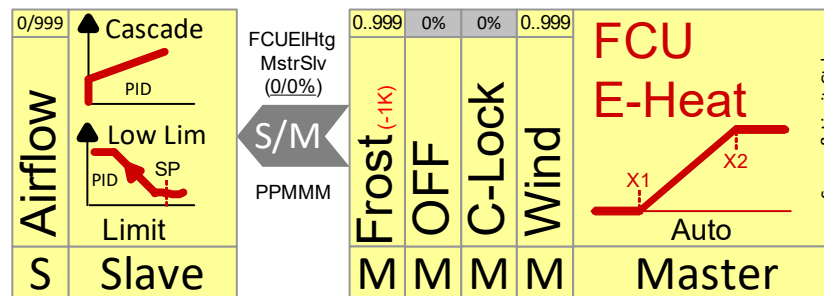

Conditions and Overrides

The electrical heating signal can be overridden in the following ways:

If ... condition If ... configured	Then Override / Action for Heating coil is...	Master (M) Slave (S)	Priority
Effective Control Mode	If the mode is not heating, heating signal is ignored	M	
Window contact	If window is open, heating coil is set to configurable position or the window contact can be ignored	M	
C-Lock	If the setpoint is in cooling mode, the heating signal is set to 0 %	M	
OFF	If OFF selected on wall module, heating signal is set to off (=0%)	M	
Frost	If frost condition is true, heating coil is opened (=100 %) or can be ignored	M	
Airflow contact	If fan command is active and airflow is not confirmed, heating coil is set to fixed position (= %) or can be ignored. The fixed level is maintained for a predefined time period after airflow has been established	M+S	

Fan

Fan Sequence Logic

The following schematic shows the logic for the fan (master-slave behavior included). For a general description of a sequence logic in master-slave configuration, please refer to section "Master-Slave Controllers", p. 80.

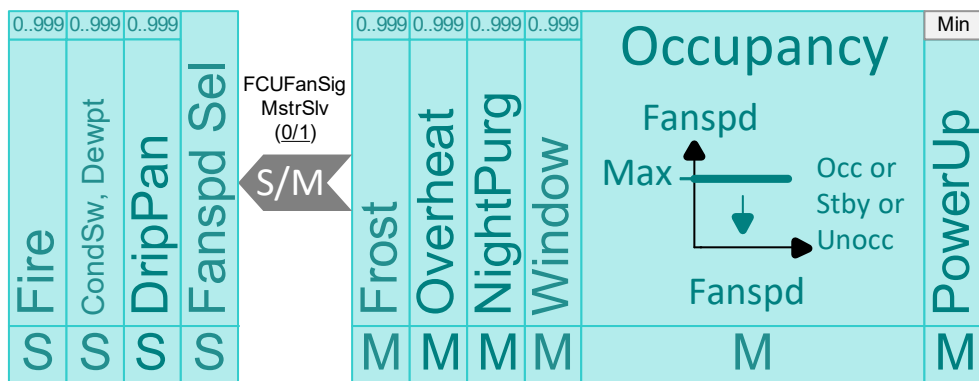

Conditions and Overrides

The fan control signal can be overridden in the following ways:

If ... configured If ... condition	Then Override / Action for Fan is...	Master (M) Slave (S)	Priority
PowerUp	If enabled, the fan switches after powerup to configured minimum fan speed. If disabled, it may take some minutes until the fan is turned on according to the overall temperature control. Recommended for countries with high temperatures.	M	low
Occupancy mode	The fan speed can be optimized for different occupancy modes. For occupied (including bypass) and standby min. and max. fan speeds can be configured. For unoccupied mode (including holiday) a max. fan speed can be configured. Settings are considered for countries with high-temperatures and noise reduction.	M	
Window contact	If window is open, the fan is set to configurable position or the window contact can be ignored	M	
Night Purge	If Night Purge condition is true, the fan is set to configurable position or can be ignored.	M	
Overheat	If overheat condition is true, fan is set to fixed position or can be ignored	M	
Frost	If frost condition is true, fan is set to fixed position or can be ignored	M	
Fan speed selection	The fan speed control of the wall module can be used to override the fan speed for all occupancy modes	M+S	
Drip-pan	If drip-pan alarm is activated, fan speed is set to fixed position or can be ignored	M+S	
Condensation	If condensation (switch or dewpoint calculation) is activated, fan speed is set to fixed position or can be ignored	M+S	
Fire	If fire switch is activated, fan speed is set to fixed position or can be ignored	M+S	

For further basic and detailed descriptions on the fan, please refer to the section "Fans", p. 47.

CEILING

Ceiling systems in commercial buildings control room temperature through the control of cold and/or hot water valves. Connection of a humidity sensor allows calculation of the dewpoint and the chilled cold water temperature sensor allows condensation prevention. Condensation can also be prevented via condensation switch.

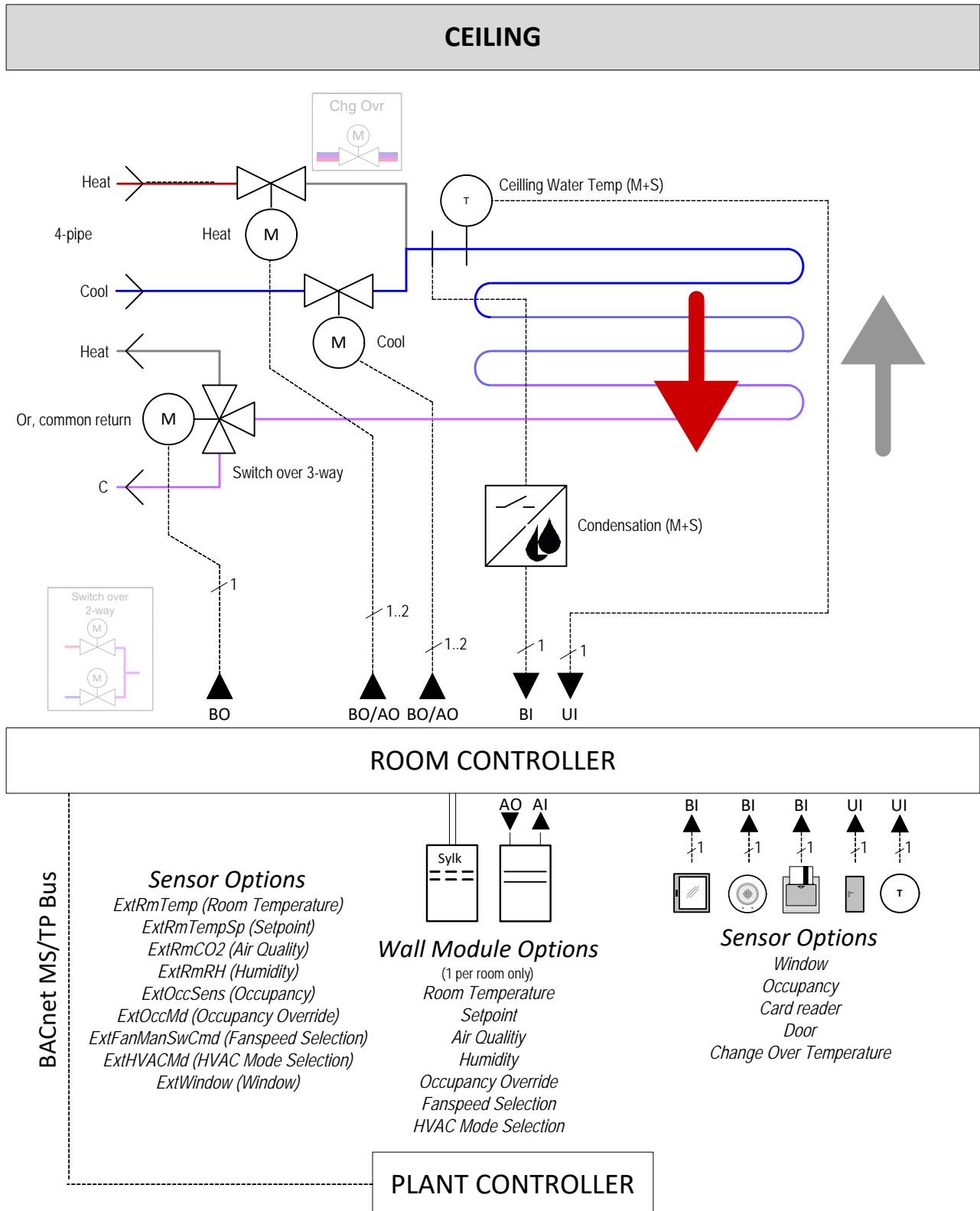

Fig. 4. Ceiling control application

CEILING (6-WAY-MID VALVE)

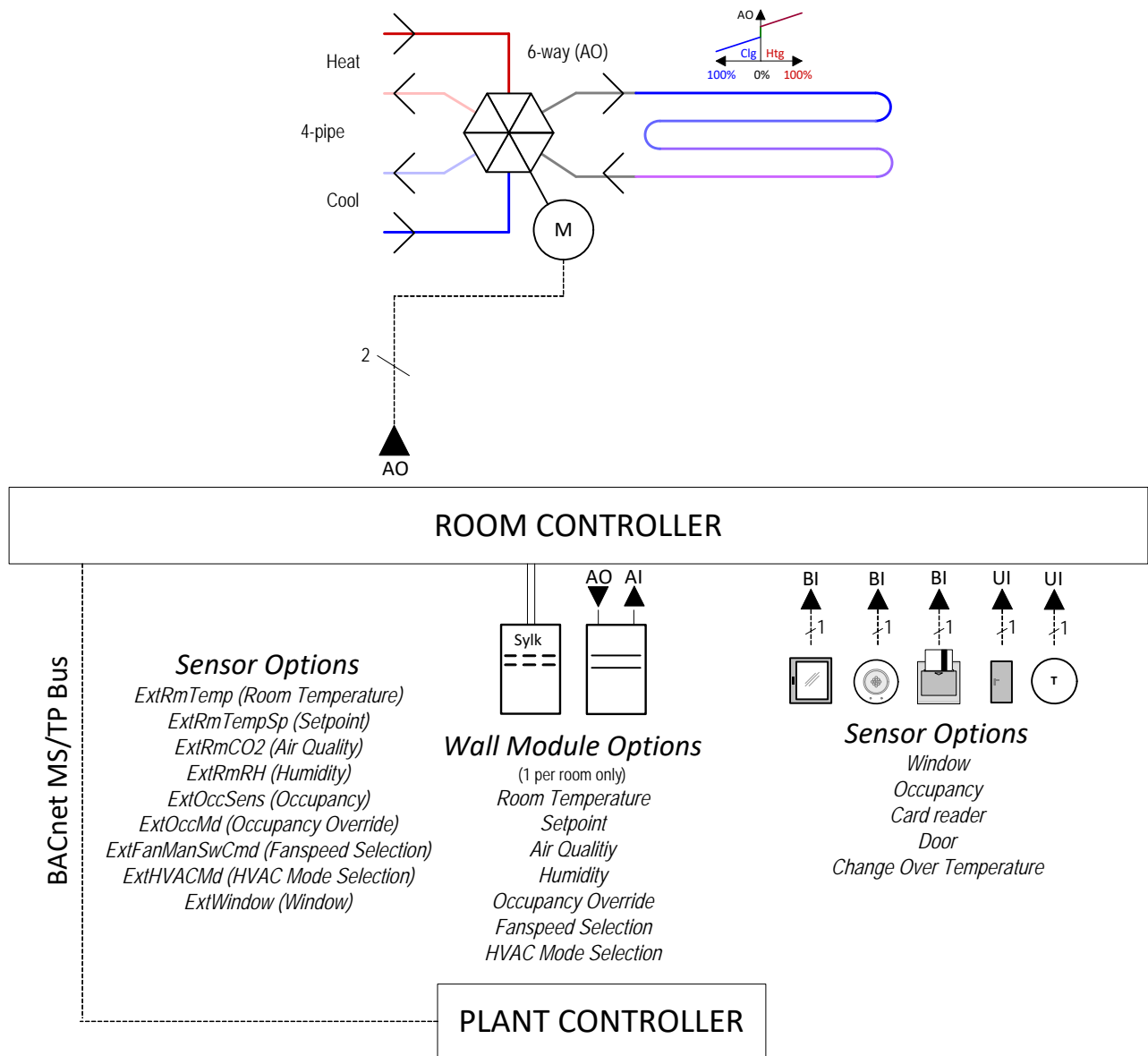

Fig. 5. Ceiling 6-Way-MID Valve control application

Basic Features

The ceiling application type supports:

Inputs

- Assigned via wall module and explicit sensor selection (see section “Advanced Features”, p. 2222).

Equipment Configurations

- water cooling and water heating
- 2-pipe changeover, 4-pipe systems
- 4-pipe system with 6-way MID valve (AO)
- Cooling / Heating switchover for 2-way and 3-way valves
- Wall module Off (applies to conventional wall modules only)

For detailed information on equipment configuration, please refer to the section “Sequence Logic, Conditions and Overrides”, p. 22.

Control Strategy

- Space temperature control
- Condensation detection

For detailed information on control strategy, please refer to the section “Control Strategy”, p. 41.

Control Sequence Configuration

- Start and end levels for cooling and heating

For detailed information on control sequence configuration, please refer to the section “Sequence Configuration”, p. 41.

Outputs

- 0/2..10 V
- Floating
- PWM

For detailed information on outputs, please refer to the sections “Actuators”, p. 76 and “Free inputs and outputs”, p. 61.

Advanced Features

Additionally, the following functions can be selected for the ceiling application:

- Window contact
- Frost protection
- Overheat protection
- Night purge
- Condensation switch

For detailed information on the settings of the advanced functions, please refer to the “Sequence Logic, Conditions and Overrides”, p. 22 and the following sections:

- Window contact: “Window Contact”, p. 75
- Frost and overheat protection: “Temperature Protection”, p. 37
- Night purge: “Night Purge”, p. 37
- Condensation Switch: “Condensation”, p. 74

Sequence Logic, Conditions and Overrides

Ceiling Cooling Stage

If ceiling is configured as cooling stage, the cooling stage will modulate in parallel with other cooling sequences based on the space temperature control setpoints.

This stage will only be controlled by space temperature control and will not be affected by cascade or limiting control.

Sequence Logic

The following schematic shows the logic for the ceiling cooling stage (master-slave behavior included). For a general description of a sequence logic in master-slave configuration, please refer to section “Master-Slave Controllers”, p. 80.

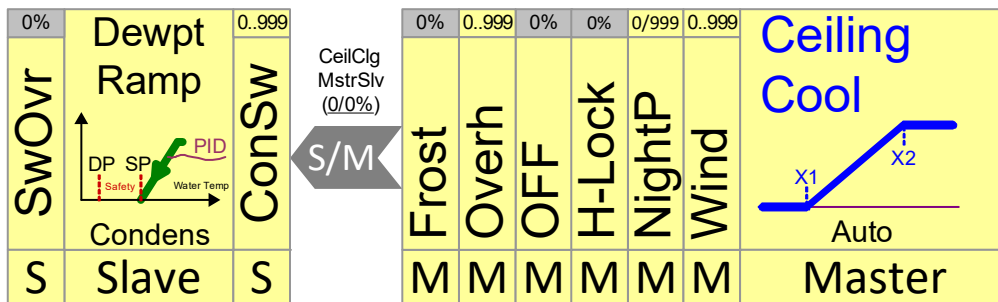

Conditions and Overrides

The ceiling cooling stage can be overridden in the following ways:

If ... configured If ... condition	Then Override / Action for Cooling stage is...	Master (M) Slave (S)	Priority
Effective Control Mode	If the mode is not cooling, cooling stage is closed	M	 <p>low</p> <p>high</p>
Window contact	If window is open, cooling stage is set to configurable position or the window contact can be ignored	M	
Night purge	It can be configured whether the cooling stage ignores Night Purge or it closes to 0%.	M	
H-Lock	If the setpoint is in heating mode, the cooling signal is set to 0 %	M	
OFF	If OFF selected on wall module, cooling stage is closed (= %)	M	
Overheat	If overheat condition is true, cooling stage is set to fixed position (= %) or can be ignored	M	
Frost	If frost condition is true, cooling stage is closed (= %) or can be ignored	M	
Condensation Switch	If the condensation switch is activated, the cooling stage is overridden to fixed position.	M	
Dewpoint	To protect against condensation forming, the ceiling cooling stage will modulate to close (as the ceiling chilled water temperature decreases to approach the ceiling dewpoint temperature.	M	
Switch Override	As long as the switchover process is not finished (change be heating and cooling mode and vice versa) the valve remains closed.	M+S	

NOTE: Balancing is triggered via RoomUp bulk command. The bulk command is a manual override via BACnet to the priority 8 of the corresponding BACnet object. Please make sure to relinquish the manual overrides in order to allow the controller to start with automatic control again. During balancing the ceiling cooling stage is in a fully open or closed state (configurable in RoomUp) irrespective of other settings.

Ceiling Heating Stage

If ceiling is configured as heating stage, the ceiling heating stage modulates in conjunction with other heating sequences based on the space temperature control setpoints. This stage is controlled by space temperature control and is not affected by cascade or limiting control.

Sequence Logic

The following schematic shows the logic for the ceiling heating stage (master-slave behavior included). For a general description of a sequence logic in master-slave configuration, please refer to section "Master-Slave Controllers", p. 80.

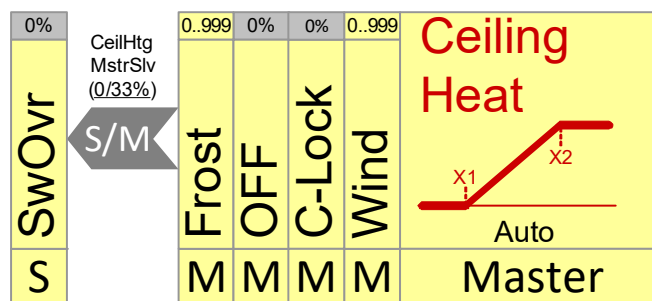

Conditions and Overrides

The ceiling heating stage can be overridden in the following ways:

If ... configured If ... condition	Then Override / Action for Heating stage is...	Master (M) Slave (S)	Priority
Effective Control Mode	If the mode is not heating, heating stage is closed	M	
Window contact	If window is open, heating stage is set to configurable position or the window contact can be ignored	M	
Night purge	It can be configured whether the heating stage ignores Night Purge or it closes to 0%.	M	
C-Lock	If the setpoint is in cooling mode, the heating signal is set to 0 %	M	
OFF	If OFF selected on wall module, heating stage is closed (=0%)	M	
Frost	If frost condition is true, heating stage is opened (=100 %) or can be ignored	M	
Switch Override	As long as the switchover process is not finished (change be heating and cooling mode and vice versa) the valve keeps closed.	M+S	

NOTE: Balancing is triggered via RoomUp bulk command. The bulk command is a manual override via BACnet to the priority 8 of the corresponding BACnet object. Please make sure to relinquish the manual overrides in order to allow the controller to start with automatic control again. During balancing the ceiling heating stage is in a fully open or closed state (configurable in RoomUp) irrespective of other settings

Switchover Piping Configuration

Since a ceiling application uses only one register, RoomUp provides the switch-over function which allows the external switching from heating to cooling and vice versa.

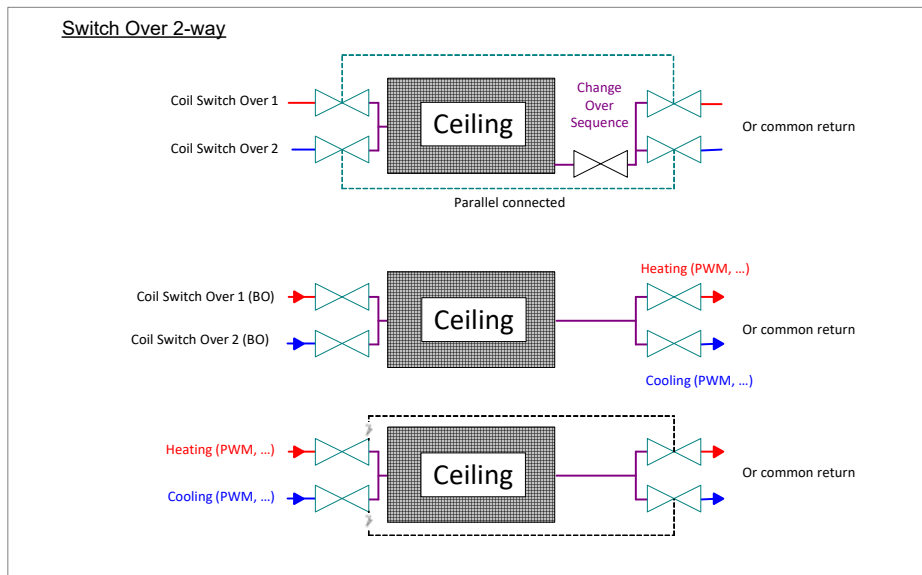

Fig. 6. Ceiling Switch-Over Configuration with 2-way valve

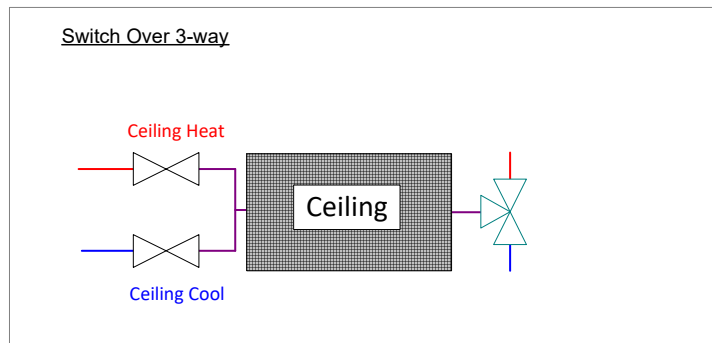

Fig. 7. Ceiling Switch-Over Configuration with 3-way valve

Radiator

The radiator application controls the room temperature in parallel with other heating sequences based on the space temperature control setpoints.

Additionally, low limit control strategy can be used by adding a radiation sensor (typically below the window) and enabling low limit depending on the outside air temperature signal.

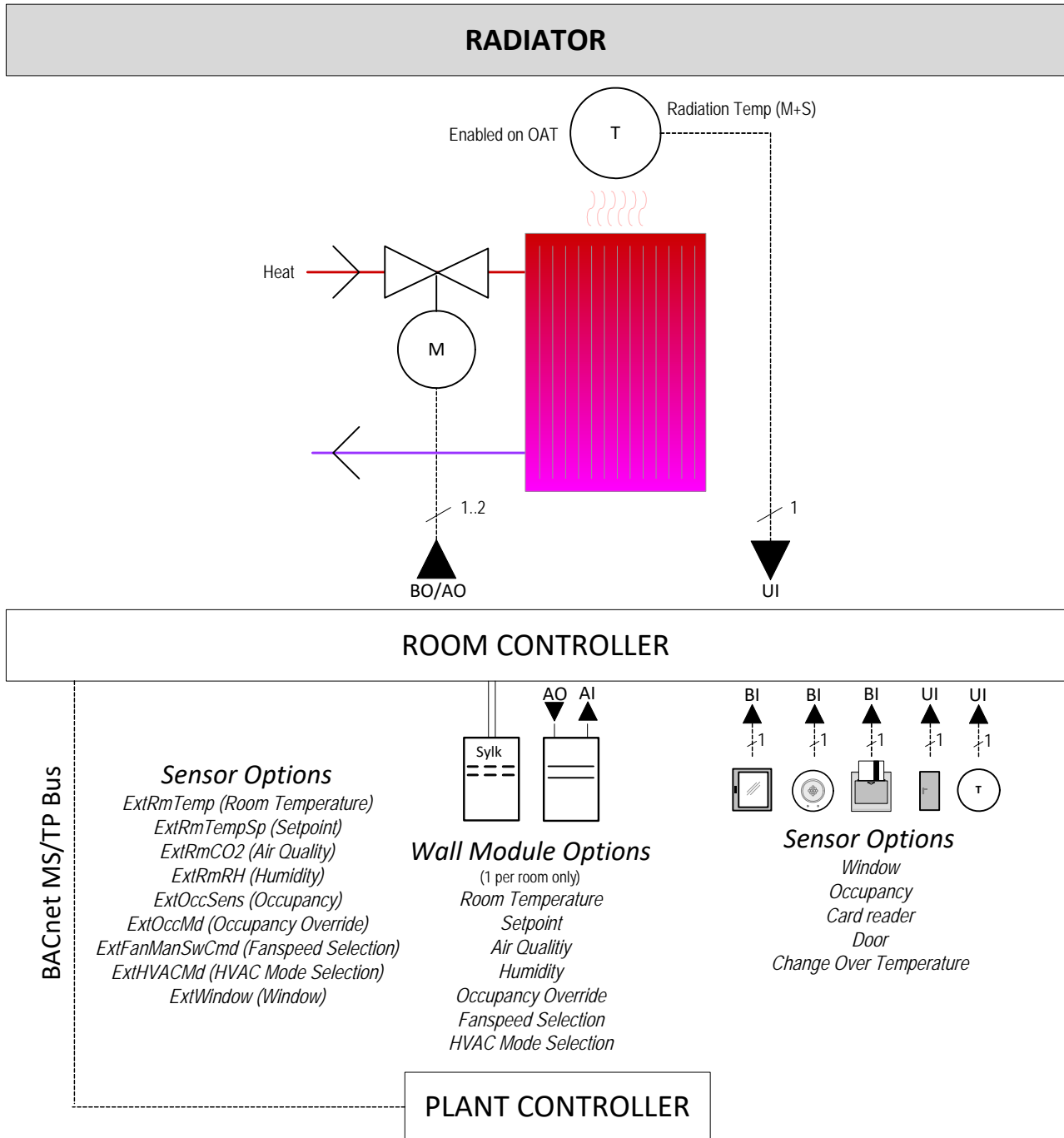

Fig. 8. Radiator control application

Basic Features

The radiator application type supports:

Inputs

- Assigned via wall module and explicit sensor selection (see section “Advanced Features”, p. 27).

Equipment Configurations

- Heating
- Wall module Off (applies to conventional wall modules only)

For detailed information on equipment configuration, please refer to the section “Sequence Logic, Conditions and Overrides”, p. 27.

Control Strategy

- Space temperature control
- Low limit heating control

For detailed information on control strategy, please refer to the section “Control Strategy”, p. 41.

Control Sequence Configuration

- Start and end levels for heating

For detailed information on control sequence configuration, please refer to the section “Sequence Configuration”, p. 41.

Outputs

- 0/2..10 V
- Floating
- PWM

For detailed information on outputs, please refer to the sections “Actuators”, p. 76 and “Free inputs and outputs”, p. 61.

Advanced Features

Additionally, the following functions can be selected for the radiator application:

- Window contact
- Frost protection

For detailed information on the settings of the advanced functions, please refer to the section “Sequence Logic, Conditions and Overrides”, p. 27 and the following sections:

- Window contact: “Window Contact”, p. 75
- Frost and overheat protection: “Temperature Protection”, p. 37

Sequence Logic, Conditions and Overrides

Sequence Logic

The following schematic shows the logic for the Radiator Heating stage (master-slave behavior included). For a general description of a sequence logic in master-slave configuration, please refer to section “Master-Slave Controllers”, p. 80.

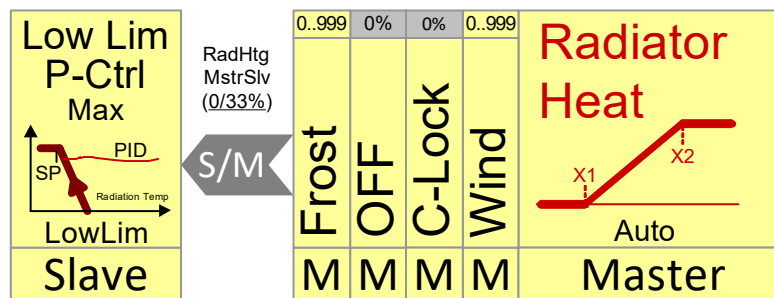

Conditions and Overrides

The radiator heating valve can be overridden in the following ways:

If ... condition If ... configured	Then Override / Action for Radiator is...	Master (M) Slave (S)	Priority
Effective Control Mode	If the mode is not heating, heating signal is ignored	M	 low high
Window contact	If window is open, heating valve is set to configurable position or the window contact can be ignored	M	
Night purge	It can be configured whether the heating valve ignores Night Purge or it closes to 0%.	M	
C-Lock	If the setpoint is in cooling mode, the heating signal is set to 0 %	M	
OFF	If OFF selected on wall module, heating valve is closed (=0%)	M	
Frost	If frost condition is true, heating valve is opened (=100 %) or can be ignored	M	
Low limit control	If the radiation temperature is below the defined low limit setpoint and below the defined outside air temperature, the heating valve is opened to max. position	M+S	

NOTE: Balancing is triggered via RoomUp bulk command. The bulk command is a manual override via BACnet to the priority 8 of the corresponding BACnet object. Please make sure to relinquish the manual overrides in order to allow the controller to start with automatic control again. During balancing the radiator heating valve is in a fully open or closed state (configurable in RoomUp) irrespective of other settings.

Underfloor Heating

The underfloor application modulates the room temperature in conjunction with other heating sequences based on the space temperature control setpoints. In addition, an underfloor discharge sensor can be applied in order to prevent overheating of the underfloor.

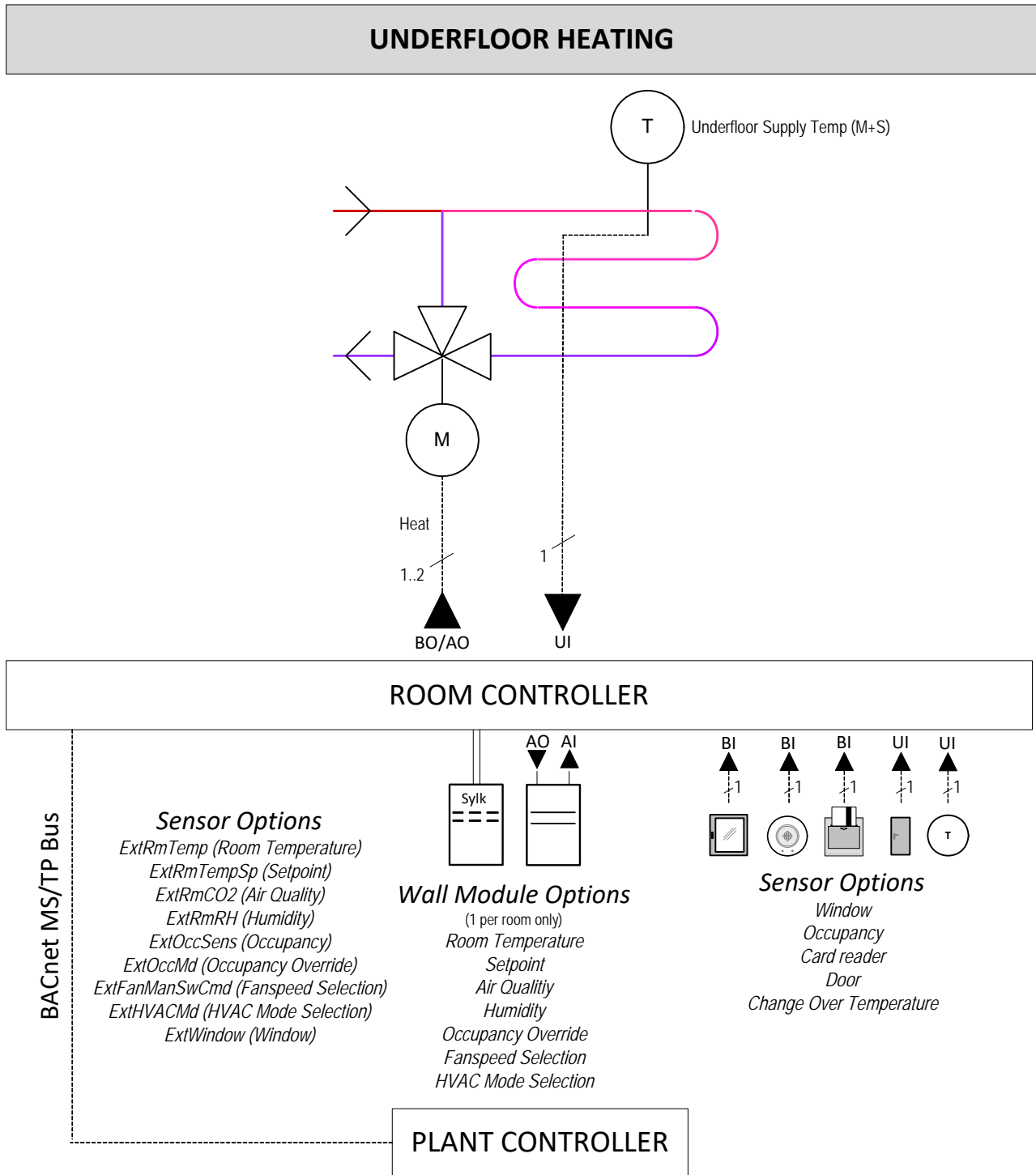

Fig. 9. Underfloor Heating Control Application

The underfloor application type supports:

Inputs

- Assigned via wall module and explicit sensor selection (see section “Advanced Features“, p. 30).

Equipment Configurations

- Heating
- Wall module Off (applies to conventional wall modules only)

For detailed information on equipment configuration, please refer to the section “Sequence Logic, Conditions and Overrides“, p. 30.

Control Strategy

- Space temperature control
- High limit heating control

For detailed information on control strategy, please refer to the section “Control Strategy“, p. 41.

Control Sequence Configuration

- Start and end levels for heating

For detailed information on control sequence configuration, please refer to the section “Sequence Configuration“, p. 41.

Outputs

- 0/2..10 V
- Floating
- PWM
- 1-Stage

For detailed information on outputs, please refer to the sections “Actuators“, p. 76 and “Free inputs and outputs“, p. 61.

Advanced Features

Additionally, the following functions can be selected for the underfloor application:

- Window contact
- Frost protection

For detailed information on the settings of the advanced functions, please refer to the “Sequence Logic, Conditions and Overrides“, p. 30 and the following sections:

- Window contact: “Window Contact“, p. 75
- Frost and overheat protection: “Temperature Protection“, p. 37

Sequence Logic, Conditions and Overrides

Sequence Logic

The following schematic shows the logic for the underfloor heating stage (master-slave behavior included). For a general description of a sequence logic in master-slave configuration, please refer to section “Master-Slave Controllers“, p. 80.

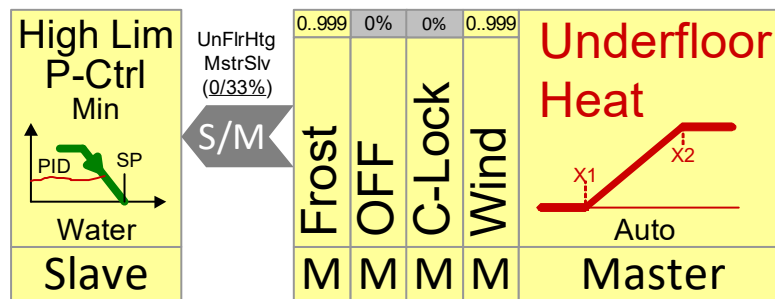

Conditions and Overrides

The underfloor heating valve position can be overridden in the following ways:

If ... condition If ... configured	Then Override / Action for Underfloor heating is...	Master (M) Slave (S)	Priority
Effective Control Mode	If the mode is not heating, heating signal is ignored	M	
Window contact	If window is open, heating valve is set to configurable position or the window contact can be ignored	M	
Night purge	It can be configured whether the heating valve ignores Night Purge or it closes to 0%.	M	
C-Lock	If the setpoint is in cooling mode, the heating signal is set to 0 %	M	
OFF	If OFF selected on wall module, heating valve is closed (=0%)	M	
Frost	If frost condition is true, heating valve is opened (=100 %) or can be ignored	M	
High limit control	To prevent overheating, the underfloor heating valve will be modulated to close position if the heating water temperature increases towards the high limit heating setpoint	M+S	

NOTE: Balancing is triggered via RoomUp bulk command. The bulk command is a manual override via BACnet to the priority 8 of the corresponding BACnet object. Please make sure to relinquish the manual overrides in order to allow the controller to start with automatic control again. During balancing the heating valve is in a fully open or closed state (configurable in RoomUp) irrespective of other settings

Intake Air

If configured as a stage of cooling, the intake air damper modulates the room temperature in parallel with other cooling sequences based on the space temperature control setpoints. In addition, air quality measurement and control can be applied.

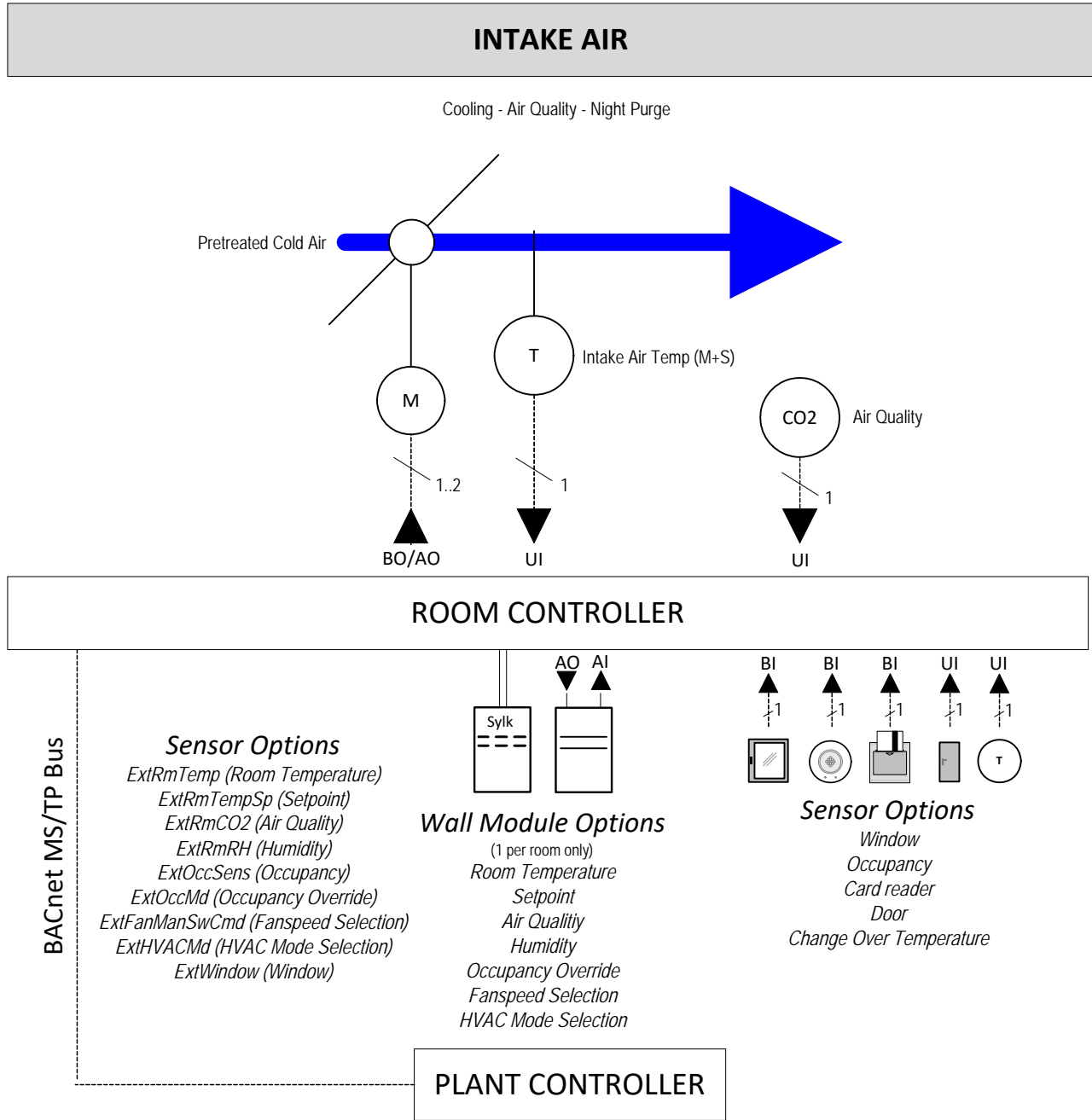

Fig. 10. Intake Air control application

Basic Features

The intake air application type supports:

Inputs

- Assigned via wall module and explicit sensor selection (see section “Advanced Features”; p. 33).

Equipment Configurations

- Cooling
- Air Quality control
- Cooling and Air Quality control
- Wall module Off (applies to conventional wall modules only)

For detailed information on equipment configuration, please refer to the section "Sequence Logic, Conditions and Overrides", p. 34.

Control Strategy

- Space temperature control
- Space temperature with low limit cooling

For detailed information on control strategy, please refer to the section "Control Strategy", p. 41.

Control Sequence Configuration

- Start and end levels for cooling

For detailed information on control sequence configuration, please refer to the section "Sequence Configuration", p. 41.

Outputs

- 0/2..10 V
- Floating
- On-Off

For detailed information on outputs, please refer to the sections "Actuators", p. 76 and "Free inputs and outputs", p. 61.

Advanced Features**Cooling**

Additionally, the following advanced functions can be selected for the cooling part of the intake air application:

- Window contact
- Overheat protection
- Night purge

For detailed information on the settings of the advanced functions, please refer to the section "Sequence Logic, Conditions and Overrides", p. 34 and the following sections:

- Window contact: "Window Contact", p. 75
- Frost and overheat protection: "Temperature Protection", p. 37
- Night purge: "Night Purge", p. 37

Sequence Logic, Conditions and Overrides

Sequence Logic

The following schematic shows the logic for the Intake Air stage (master-slave behavior included). For a general description of a sequence logic in master-slave configuration, please refer to section “Master-Slave Controllers”, p. 80.

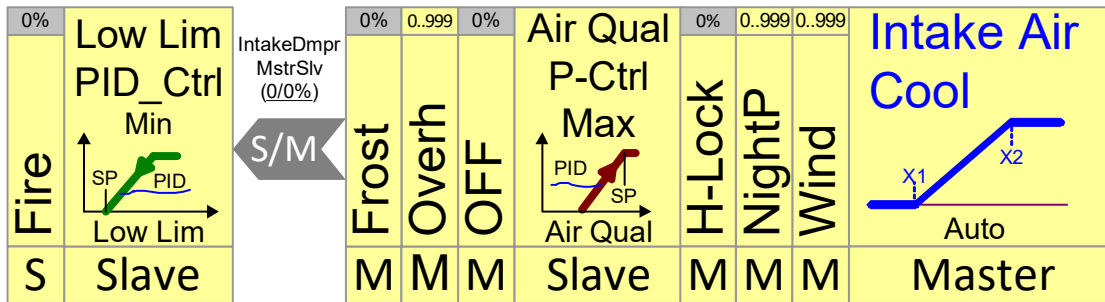

Conditions and Overrides

The intake air damper can be overridden in the following ways:

If ... condition If ... configured	Then Override / Action for Intake air is...	Master (M) Slave (S)	Priority
Effective Control Mode	If the mode is not cooling, intake air damper is closed	M	
Window contact	If window is open, intake air damper is set to configurable position or the window contact can be ignored	M	
Night purge	It can be configured whether the intake air damper ignores Night Purge or a value 0..100%.	M	
H-Lock	If the setpoint is in heating mode, the cooling signal is set to 0 %		
Air Quality P-Control	The intake air damper is overridden to maintain air quality. In the event the room carbon dioxide sensor detects levels greater than the effective air quality setpoint, the intake air damper will be opened to lower these levels. Air quality function can be applied in cooling and/or heating mode or enabled in general		
OFF	If OFF selected on wall module, intake air damper is closed (=0%)	M	
Overheat	If overheat condition is true, intake air damper is set to fixed position (= %) or can be ignored	M	
Frost	If frost condition is true, intake air damper is closed (= %) or can be ignored	M	
Low limit control	The intake air damper is controlled to maintain intake air intake temperatures above a configured low limit cooling setpoint	M+S	
Fire	If condition is true, intake air damper is closed (0 %)	M+S	

NOTE: Balancing is triggered via RoomUp bulk command. The bulk command is a manual override via BACnet to the priority 8 of the corresponding BACnet object. Please make sure to relinquish the manual overrides in order to allow the controller to start with automatic control again. During balancing, the intake air damper will be overridden fully open.

COMMON SETTINGS

The following common settings are valid for all cooling and heating applications if applicable.

Space Temperature Setpoints

The heating and cooling space temperature setpoints are configurable for the following room modes:

- occupied/bypass
- standby
- unoccupied/holiday

The setpoints are switched as the occupancy changes.

Parameter	Range / Selection	Default
Cooling Occupied [OccClgSp.RelDefault]	-50..150 °C	23 °C
Cooling Standby [StbyClgSp.RelDefault]	-50..150 °C	25 °C
Cooling Unoccupied [UnOccClgSp.RelDefault]	-50..150 °C	28 °C
Heating Occupied [OccHtgSp.RelDefault]	-50..150 °C	21 °C
Heating Standby [StbyHtgSp.RelDefault]	-50..150 °C	19 °C
Heating Unoccupied [UnOccHtgSp.RelDefault]	-50..150 °C	16 °C

In addition, the following advanced settings can be defined:

Parameter	Range / Selection	Default	Description
Delay before Cool / Heat Mode change	0..3600 sec	60 sec	Time delayed switching to reduce toggling.
Delay after Cool / Heat Mode change	0..3600 sec	225 sec	Valves are closed (Off), no energy mixture.
Wall module rel/abs Setpoint shift during Occupancy Mode [WM_Sp_Calc_Occ_Sp_Shift_Rng]	0..18	5	Base = 21 °C/69.8 °F: setpoint shift of +/- defined value via module in occupancy mode
Wall module rel/abs Setpoint shift during Standby Mode [WM_Sp_Calc_Stby_Sp_Shift_Rng]	0..18	5	Base = 21 °C/69.8 °F: setpoint shift of +/- defined value via module in standby mode
Wall module rel/abs Setpoint shift during Unoccupancy Mode [WM_Sp_Calc_UnOcc_Sp_Shift_Rng]	0..18	0	Base = 21 °C/69.8 °F: setpoint shift of +/- defined value via module in unoccupancy mode
Reset wall module Setpoint, Override Occupancy, Fan Speed Selection, HVAC Mode	No Reset Scheduler change to Unocc	No Reset	
Summer compensation, start of outside air temp (X1)	-50..150 °C	28	Outside air temperature where the summer compensation starts.
Summer compensation, end of outside air temp (X2)	-50..150 delta °C	38	Outside air temp where the setpoint has the maximum increase
Increase of summer compensation [SummerComp_Rst_Rng]	-50..150 delta °C	9	Maximum increase of the setpoint at X2

Occupancy Mode

These settings define common occupancy functions of the:

- bypass button of the wall module:
short and long press behavior and the bypass time (conventional wall modules only)
- card reader:
time delay for detecting the pulled-out card
- occupancy sensor / door contact:
occupancy sensor and door contact usage for occupancy detection and time limits for occupancy detection

Setting	Range / Selection	Default	Description
Button Short Press	Leaving = Switch to Unoccupied until Scheduler changes	"none"	When leaving and pressing bypass button short, mode switches to unoccupied until scheduler changes next time (applies to conventional wall modules only)
Button Long Press	Holiday = Switch to Unoccupied until next press or until the WMExtRst*	"none"	When pressing bypass button long during occupied, mode switches to holiday/unoccupied until next press or until the WMExtRst (applies to conventional wall modules only)
Occupancy Sensor / Card Reader (Scheduler default = Occ)	Switch from Unocc / Stby to Occ Switch from Stby to Occ Switch from Occ to Stby Switch from Occ to Unocc	Not used	Defines the action executed when detecting presence / non-presence via occupancy sensor and/or card reader
Bypass Time [WM_Push_Button_Bypass_Time]	0..10080 min	180 min	Bypass mode is active for defined time when the bypass button was pressed
Card Reader Off Hold Time	0..86400 sec	60 sec	Time delay. Application detects card as "pulled out" after this time
Logic for Occupancy Sensor and Door Contact	Occ Sensor only Occ Sensor only + Door contact	Occ Sensor only	Detects occupancy using sensor only, or using both, sensor and door contact
Occupancy Sensor On Delay Time	0..86400 sec	15 sec	Time after which occupancy is detected at the earliest
Occupancy Sensor Off Hold Time	0..86400 sec	900 sec	Delay after the last detection of occupancy

*Holiday mode can be reset by using the WMExtRst function

Limit Control

This setting defines that the heating low limit control (FCU and Radiator) only works as long as the outside air temperature is below a defined temperature value. This setting is important for cold regions, e.g. Northern Europe.

Setting	Range	Default	Remark
Low Limit Heating works until outside air temperature is below (1 K Hyst)...	-50..150 °C	-25 °C	Hysteresis = 1K applied

Dewpoint

This setting defines a dewpoint temperature if the dewpoint cannot be calculated due to missing dewpoint and/or humidity sensors.

Setting	Range	Default
Dewpoint if it cannot be calculated [Ceil_Dew_Point_Calc_Sp]	0..150 °C	35 °C

Temperature Protection

Temperature protection is provided for frost and overheat conditions. Both functions are supported by the common space temperature sensor of the wall module.

Setting	Range / Value	Default
Frost space temperature [RmFrostSp.ReDefault]	-50..150 °C	8 °C
Frost space hysteresis	0.25..100 K	1 K
Overheat space temperature [RmOvrHtgSp.RelDefault]	-50..150 °C	35 °C
Overheat hysteresis	0.25..100 K	1 K

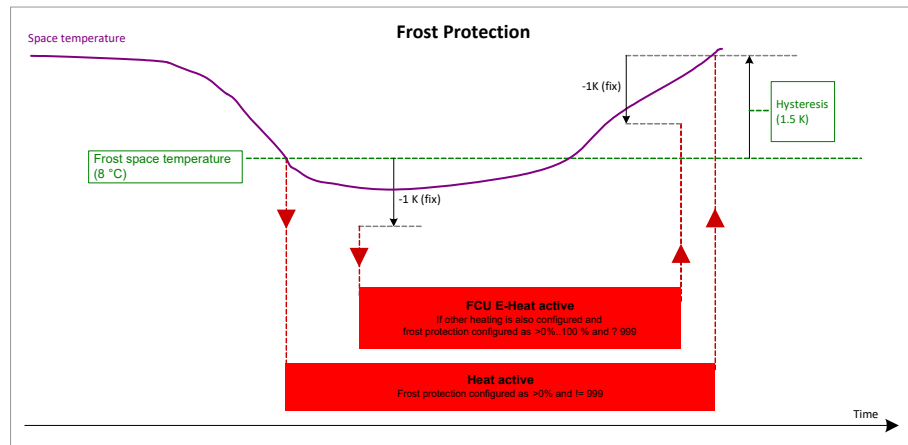

Fig. 11. Frost Protection Example

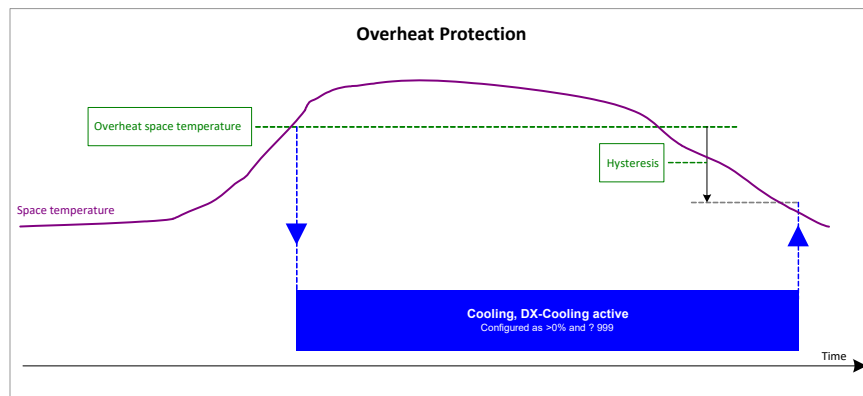

Fig. 12. Overheat Protection Example

Night Purge

These settings define the occupancy modes (grouped) for which night purge can be enabled. It can also be defined if night purge should be enabled or not if the unit and the fan are Off.

Setting	Range / Selection	Default
Enabled if Occupancy Mode [OccMode] is	Holiday, Unoccupied, Standby, Occupied, Bypass Holiday, Unoccupied, Standby Holiday, Unoccupied	Holiday, Unoccupied, Standby, Occupied, Bypass

Setting	Range / Selection	Default
Enabled during Unit Off / Fanspeed Selection Off [WMFanManSwCmd]	No Yes	No

The night purge mode uses untreated outside air [OaTemp] to reduce the space temperature during times when the outside air temp is cold enough (i.e. during night or in the early morning). Night purge is initiated from the plant controller [PltNiPrgEn] when outside air conditions are appropriate, e.g. after heat-waves. When night purge is enabled from Plant and all other night purge conditions (occupancy mode, setpoint mode, space temp, and fanspeed switch) are right [NiPurgEff], the intake air damper opens with a pre-configured position and remains open until the space temperature lies in the ZEB (zero-energy-band). This results in a comfort temperature between cooling and heating (e.g. 21 – 23 °C -> 22°C) and the cooling sequences are set to pre-defined positions.

NOTE: Nightpurge is only available if the HVAC mode [PltHVACMd] is cooling or off.

Night Purge Enable

The night purge function can be configured to operate based on the:

- occupancy mode
- fan switch position on the wall module
- room temperature relative to the occupied cooling setpoint

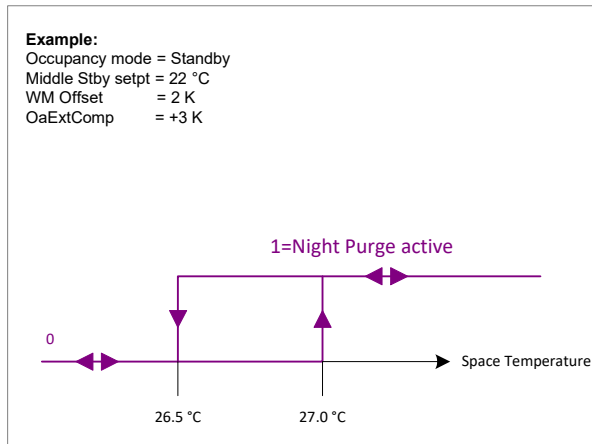

EFFECTIVE CONTROL MODE

The effective control mode [CtrlMd] is the determining base for the automatic switching between cooling and heating modes depending on the room temperature.

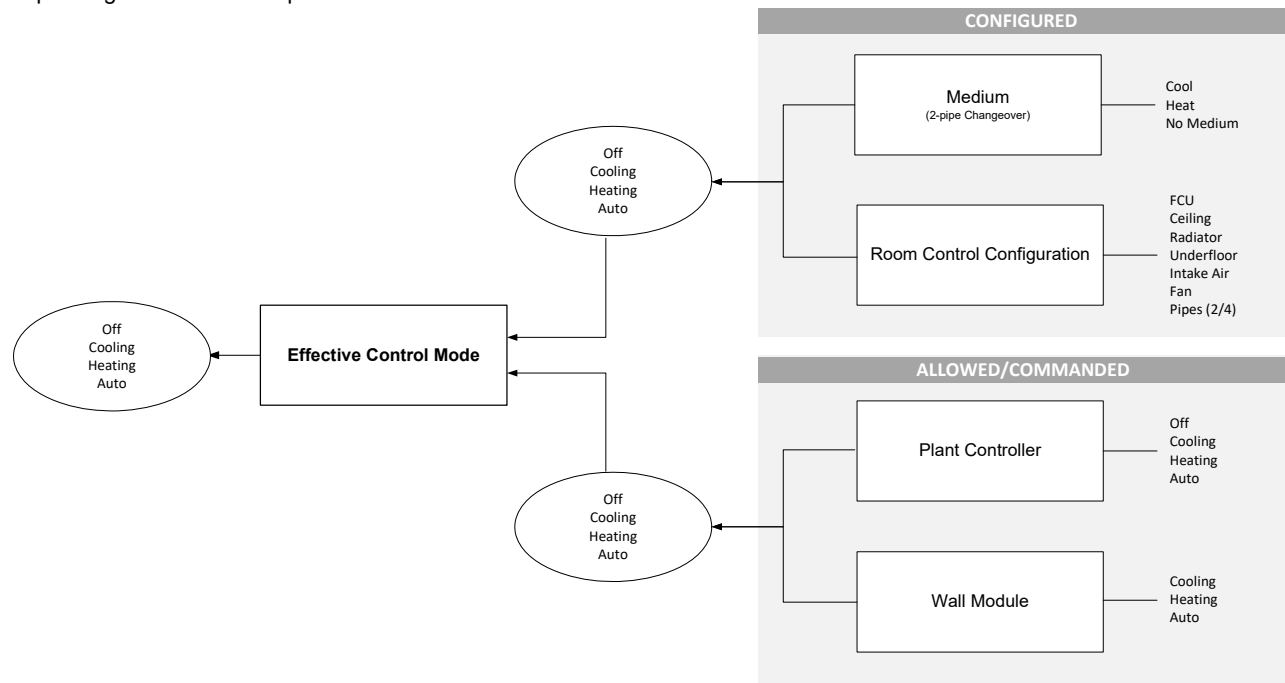

Fig. 13. Effective Control Mode

The effective control mode, that is, which control mode is executed actually, is determined by the:

- Room control configuration, e.g. ceiling cooling + radiator heating
- Medium provided for changeover applications [PltCngOvtMed] = off, cool medium, heat medium, or cool/heat changeover sensor. Sensor has higher priority than [PltCngOvrMed]
- HVAC mode from Plant controller [PltHVACMd] = off, cooling, heating, auto (cooling+heating)
- HVAC mode from wall module [WMHVACMd] = heating, cooling, auto

First, the room controller analyzes the room control configuration, that is, what kind of control, water cooling and/or heating has been configured. In addition, for 2-pipe changeover applications it analyzes the presence of the appropriate water medium [PltCngOvrMed], (cool water, hot water, no water). These are the decisive conditions based on the room configuration.

The plant controller tells the room controller by sending the HVAC mode [PltHVACMd] whether the cooling plant and/or heating plant is working. In the summer, only the cooling plant is typically working, in the winter only the heating plant is working. In the seasons between summer and winter, both, cooling and heating are working depending on the outside air temperature.

Via Syk wall module, the user can select whether he/she wants to have cooling, heating, or cooling plus heating (auto) [WMHVACMd]. By doing so, inadvertent heating or cooling is prevented. Selecting auto results in an automatic switching from cooling and heating. The active wall module setting can be reset to auto via BACnet command [WMExtRst]. These are the decisive conditions determined by plant controller and the wall module commanding.

NOTE: When applying different reset commands sequentially using [WMExtRst], you must either enter the value 1 = no reset, or wait 60 sec, before entering the next command. Otherwise the next command is ignored.

NOTE: Conventional wall modules do not support control mode commanding.

Finally, the effective control mode executed by the application for controlling the space temperature can be any of the following:

- Off
- Heating
- Cooling
- Auto (Heating + Cooling)

Effective Space Setpoint

The effective space temperature setpoint [RmTempEffSp] is calculated based on the following:

- 6 space temperature setpoints for heating and cooling [UnOccClgSp.RelDefault, StbyClgSp.RelDefault, OccClgSp.RelDefault, OccHtgSp.RelDefault, StbyHtgSp.RelDefault, UnOccHtgSp.RelDefault] for the occupancy states:
 - occupied
 - unoccupied
 - standby
- wall module setpoint (relative or absolute) [WMRmTempSp]
- BACnet object [OaExtComp]

Please refer also the section "Space Temperature Setpoint Adjustments", p. 52.

Effective Setpoint Mode

The effective setpoint mode is the same as the effective control mode, except for the Auto (Cooling+Heating) condition. Based on the room temperature, the cooling + heating (Auto) condition results in a Cooling or Heating setpoint according the following conditions:

The effective setpoint mode switches between heating and cooling based on the current space temperature in relation to the heating and cooling setpoints for occupied, unoccupied and standby modes. When the space temperature is above the cooling setpoint, the effective setpoint mode will change to cooling mode. If the space temperature is below the heating setpoint, the effective setpoint mode will change to heating mode. When the space temperature is between the heating and cooling setpoints, the current effective control mode will be maintained.

This prevents a permanent change between cooling and heating and vice versa.

After changes of the effective setpoint mode between cooling / heating, the setpoint mode is set to Off for a configurable time to avoid cold and hot water mixture.

Note that if there is no cooling sequence configured, the setpoint mode will never be set to cooling. If there is no heating sequence configured, the control mode will never be set to heating.

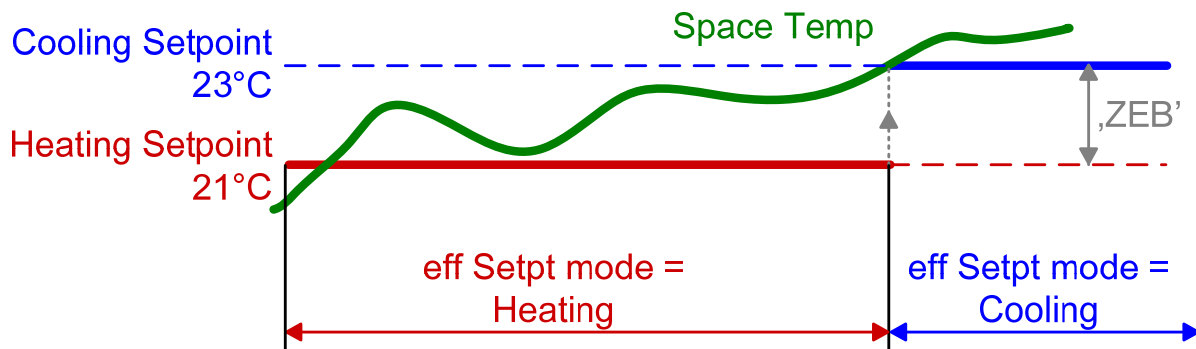

Fig. 14. Effective Setpoint Mode

CONTROL STRATEGY

The following control strategies can be applied to heating and cooling sequences:

- Space Temperature Control (all applications)
- Space Temperature with Low Limit Control for heating and/or cooling (FCU and Radiator heating only)
- Space Temperature with High Limit Control for heating (Underfloor heating only)
- Space Temperature as Cascade Control (FCU only)
- Air Quality Control (Intake air only)

Space Temperature Control

When the control application is configured to control space temperature, the heating and cooling demand signals are modulated to maintain the space temperature at the effective setpoint [RmTempEffSp]. The effective space temperature setpoint will be determined based on the controlmode (Off, Heating, Cooling, or Auto).

The basic control sequence for space temperature control is shown in Fig. 12. As space temperature [RmTemp] falls below the effective setpoint [RmTempEffSp] in case of effective setpoint mode = heating mode [CtrlSpEffMd], the heating output is increased. As space temperature increases above the effective setpoint in case of setpoint mode = cooling mode, the cooling output is modulated to 100%. Room controller uses a PID control algorithm where each of the three parameters (P-band, I-time, D-time) [Rm_Ctrl_XpClg, Rm_Ctrl_TiClg, Rm_Ctrl_TdClg, Rm_Ctrl_XpHtg, Rm_Ctrl_TiHtg, Rm_Ctrl_TdHtg] can be configured. The controller is delivered with factory defaults for each of the parameters.

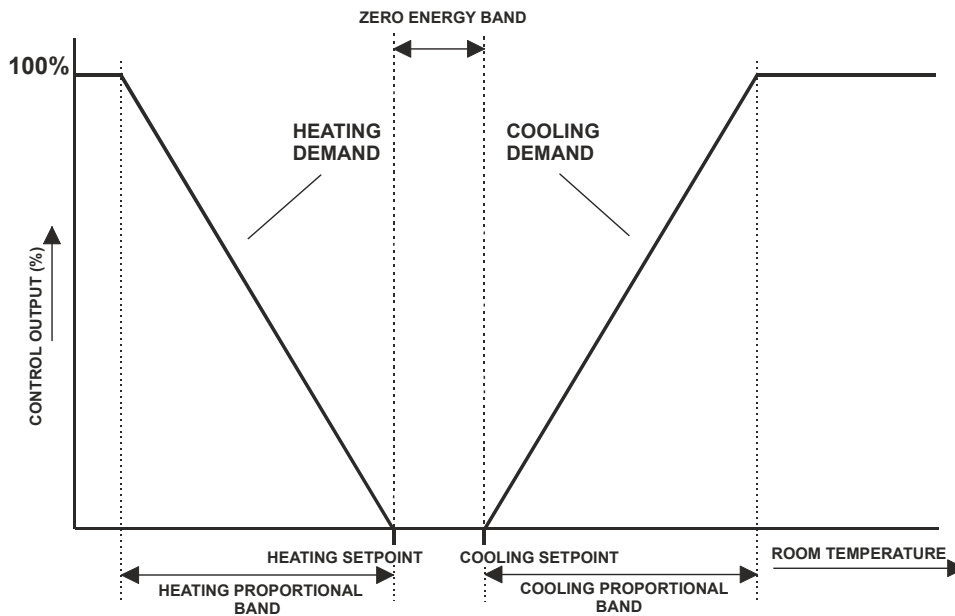

Fig. 15. Control sequence diagram (P-Control Example)

Sequence Configuration

The controller determines the control output for a sequence based on the PID input value and the configurable X1 and X2 parameters.

The X1 and X2 parameters are as follows:

Parameter	Range	Description
Start Level X1	0 – 100 %	PID controller value for starting (open valve)
End Level X2	0 – 100 %	PID controller value for ending (close valve)

The X1 and X2 parameters define the start and end levels (limits of the control range) for the sequence in %. When using the default values, 0 % for start level and 100 % for end level, multiple control sequences will work in parallel (e.g. FCU cooling and Ceiling cooling). The parameters can be used to shift parallel working sequences as follows:

Example:

First open the ceiling cooling valve and then open the FCU cooling valve by configuring X1 and X2 as follows:

Ceiling cooling: x1=0%, x2=50%

FCU cooling: x1=50%, x2=100%.

NOTE: The parameters x1, x2 are used for normal heating and cooling control and for limit control but not for cascade control.

The calculated control output via PID input value and the configurable X1 and X2 parameters is the automatic control output (lowest priority) that is visible in RoomUp and on BACnet.

For PID controller values below the start and above the end level, the control output is limited to 0 % or 100 %.

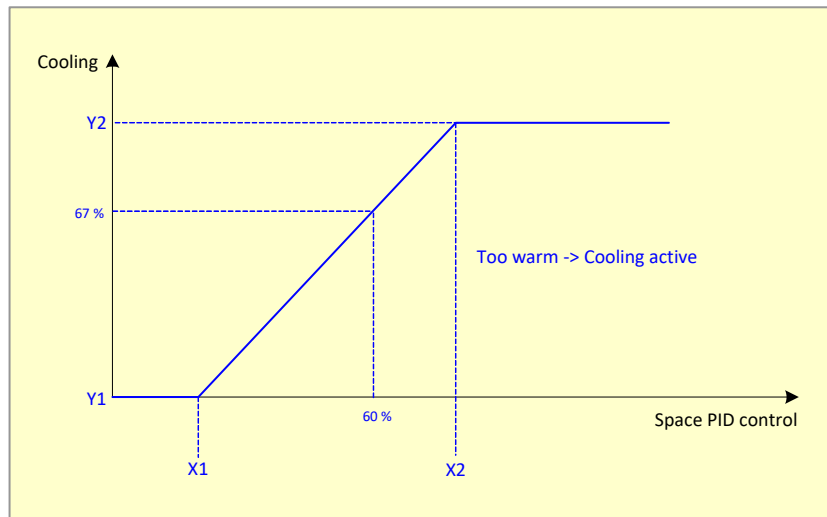

Fig. 16. Sequence Configuration (FCU Cooling Example)

Space Temperature with Limit Control

NOTE: The diagrams for the space temperature control strategy apply in principle also to the space temperature with limit control strategy.

NOTE: When applying space temperature limit control in FCU, radiator, underfloor and intake air applications, an additional temperature sensor must be installed. For configuration of the corresponding sensors, please refer to the following sections:

FCU:	“FCU Discharge Temperature Sensor“, p. 70
Radiator:	“Radiator Radiation Temperature Sensor“, p. 72
Underfloor:	“Underfloor Heating Temperature Sensor“, p. 73
Intake Air:	“Intake Air Temperature Sensor“, p. 72

Space Temperature with Low Limit Control

For FCU heating and cooling and for radiator heating, the space temperature can be controlled with a low limit control in order to maintain the discharge temperature and the radiation temperature above a minimum setpoint.

The FCU cooling sequence decreases the cooling sequence signal to maintain the discharge temperature above a minimum setpoint [FCUSaClgLoLimSp.RelinquishDefault]. The FCU heating sequence increases the heating sequence signal to maintain the discharge temperature above a minimum setpoint [FCUHtgLoLimSeq.RelinquishDefault].

The radiator heating sequence increases the heating sequence signal to maintain the radiation temperature above a minimum setpoint [Rad_Lo_Lim_Ctrl_Sp].

Space Temperature with High Limit Control

For underfloor heating, the space temperature can be controlled with a high limit control in order to maintain the underfloor discharge below a maximum setpoint [UnFlr_Htg_Hi_Lim_Ctrl_Sp].

The underfloor heating sequence decreases the heating sequence signal to maintain the underfloor discharge below a maximum setpoint.

Space Temperature as Cascade Control

Cascade control reduces uncontrolled oscillation of the space temperature due to e.g. oversized registers and/or high response times of the wall module.

Cascade control improves the performance and comfort of the plant. When the FCU is configured to control as cascade control, in a first stage, the setpoint for the discharge temperature [SaTempSp] is calculated based on the deviation between effective setpoint and current space temperature. The higher the deviation, the higher (heating) or lower (cooling) will be the calculated setpoint. The fan is also calculated as a function of the setpoint deviation. The start value is adjustable. The leading PI controller is typically a pure P controller.

In a second stage, the calculated discharge temperature setpoint will be set to a final value between the pre-configured low and high limit values [SaMinTempSp.RelDefault, SaMaxTempSp.RelDefault]. The heating and cooling control sequences are modulated to maintain the discharge temperature at the final discharge temperature setpoint.

The fan is switched off if the room temperature is within the ZEB (between cooling and heating set point) and the cooling and heating outputs are closed (0%). If both conditions are TRUE, a delay of 2 min is active until the fan stops.

As long as the heating and cooling outputs are switched on, the fan is operated at least at a minimum speed. There is a delay of 5 min if the heating and cooling outputs are closed (0%) until the fan is no longer at a minimum speed.

NOTE: For cascade control an additional FCU discharge temperature sensor must be installed [SaTemp].

If the FCU includes 2 sequences, e.g. Heating and E-Heating or Cooling and DX-Cooling, the order of sequences can be configured. The second sequence is switched On only if the first sequence is not able to reach the discharge temperature setpoint.

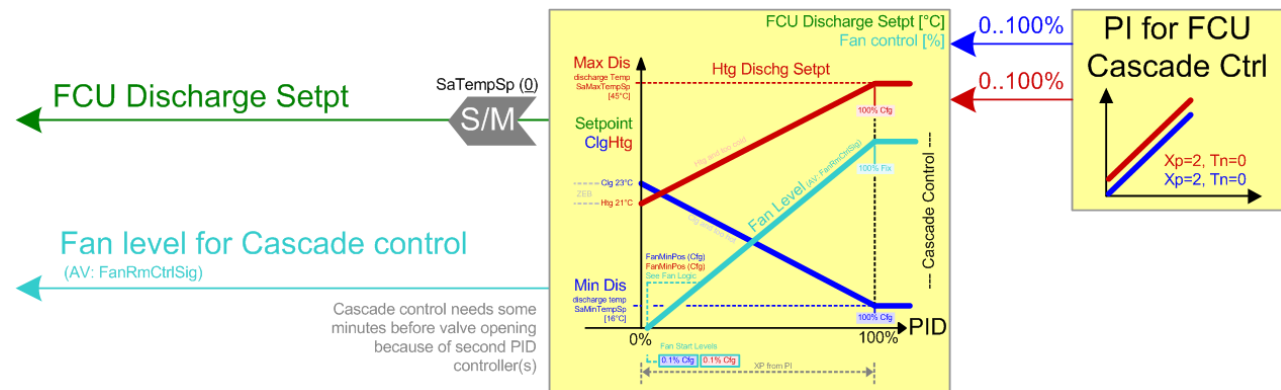

Fig. 17. Example 1: Temperature Configuration via Cascade Control

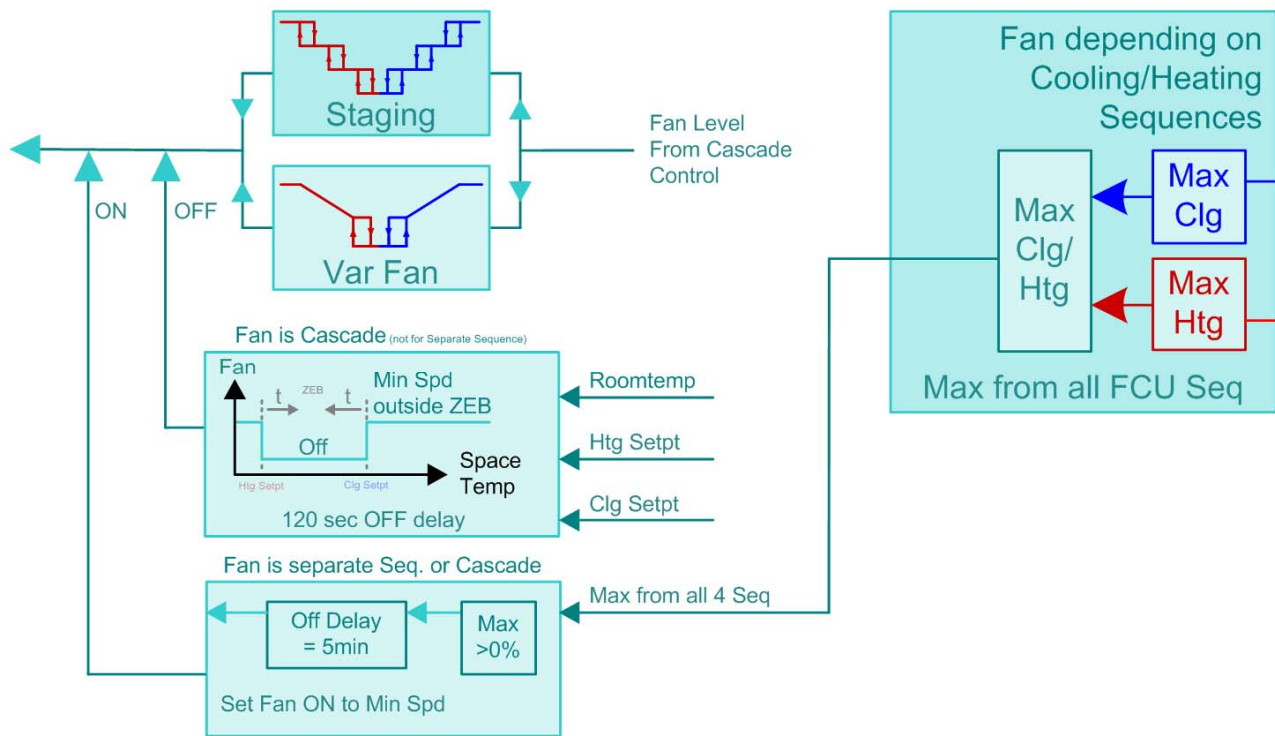

Fig. 18. Example 2 Temperature Configuration via Cascade Control

Configuration Examples

Configuration for Variable Fanspeed

Wallmodule and Sensors	
Sylk WM – TR42 (Temp °C, Humidity, CO2)	
Space Temperature – UI1	
FCU Discharge Temp - UI4	
Window contact – UI8	
Drip Pan Contact – UI2	
General Device Settings	
Space Temp Setpoints	
Advanced – Space Temp Setpts (Only for faster testing)	
Advanced – Delay before Cool/Heat Mode change – 0 sec	
Advanced – Delay after Cool/Heat Mode change – 0 sec	

Room Control – HVAC - FCU	
General	
FCU Type – Cooling+Heating	
FCU Water Pipe System – 4-pipe system	
FCU Temperature Control Type – Space Temp as Cascade ctrl	
Fan Type – Variable Speed Fan	
Fan Control Strategy – Depending on Clg / Htg Sequence	
FCU Cooling	
Analog 0/2..10V, AO1, Window Open=0%, Drip Pan 0%	
FCU Heating	
Analog 0/2..10V, AO2, Window Open=0%	
Fan	

Room Control – HVAC - FCU	
	Variable Speed
	Output Analog Output – AO3 Output Fanspeed BO – RO4 Advanced Variable Speed: 0/0.1/10/100% 0/0.1/10/70%
	Override
	Window Open - 0% Drip Pan - 0%
	FCU Ctrl Parameter
	Cascade controller Clg (Master) - Xp=2, Tn=0 Cascade controller Htg (Master) - Xp=2, Tn=0 Limits Discharge Temp - 16/45°C Cascade, PI Level for lowest/highest Setpt - 100%, 100% Cascade, PI Level from which fan is controlled - 0.1%, 0.1% Cascade Ctrl Reset Time / Xp Clg (Slave) - 8K, 300sec Cascade Ctrl Reset Time / Xp Htg (Slave) - 8K, 300sec

Configurations for Staged Fanspeed

Wallmodule and Sensors	
	Sylk WM – TR42 (Temp °C, Humidity, CO2) Space Temperature – UI1 FCU Discharge Temp - UI4 Window contact – UI8 Drip Pan Contact – UI2
	General Device Settings
	Space Temp Setpoints
	Advanced – Space Temp Setpts (Only for faster testing)
	Advanced – Delay before Cool/Heat Mode change – 0 sec Advanced – Delay after Cool/Heat Mode change – 0 sec

Room Control – HVAC - FCU	
	General
	FCU Type – Cooling+Heating FCU Water Pipe System – 4-pipe system FCU Temperature Control Type – Space Temp as Cascade ctrl Fan Type – Variable Speed Fan Fan Control Strategy – Depending on Clg / Htg Sequence
	FCU Cooling
	Analog 0/2..10V, AO1, Window Open=0%, Drip Pan 0%
	FCU Heating
	Analog 0/2..10V, AO2, Window Open=0%
	Fan
	Variable Speed
	Output Analog Output – AO3 Output Fanspeed BO – RO4 Advanced Variable Speed: 0/0.1/10/100% 0/0.1/10/70%
	Override
	Window Open - 0% Drip Pan - 0%
	FCU Ctrl Parameter
	Cascade controller Clg (Master) - Xp=2, Tn=0 Cascade controller Htg (Master) - Xp=2, Tn=0 Limits Discharge Temp - 16/45°C

Room Control – HVAC - FCU	
	Cascade, PI Level for lowest/highest Setpt - 100%, 100%
	Cascade, PI Level from which fan is controlled - 0.1%, 0.1%
	Cascade Ctrl Reset Time / Xp Clg (Slave) - 8K, 300sec
	Cascade Ctrl Reset Time / Xp Htg (Slave) - 8K, 300sec

FANS

Types

The FCU fan type is selected from:

- 1-speed fan
- 2-speed fan
- 3-speed fan
- Variable-speed fan

Multi-Speed Fan

Fans can be configured as multiple-speed (1-, 2-, or 3-speed), or variable-speed control. Fan speed and stages are controlled based on occupancy, cooling and/or heating demand depending on the configured temperature control type. During normal operation, the fan is limited by on and off delays to prevent frequent cycling of the equipment. The fan runs for a pre-configured time (fan overrun time) after heating and cooling sequences are turned off. The fan overrun time can be changed.

Multi-speed Fan Wiring

For switching the stages, multi-speed fans can be configured for either serial or parallel wiring. In serial wiring, several outputs are On at a time; in parallel wiring, only one output is On at a time. The three outputs can either triacs or relays.

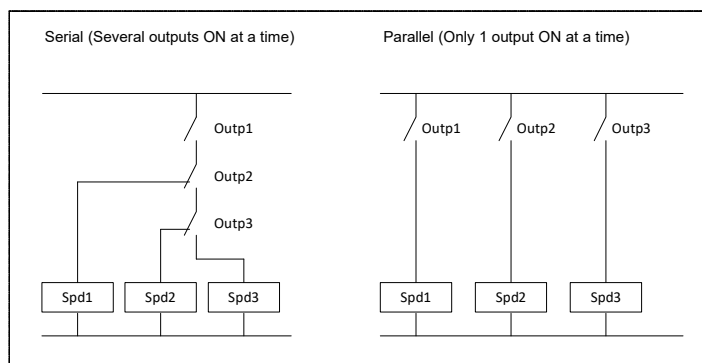

Fig. 19. Multi-speed fan wiring

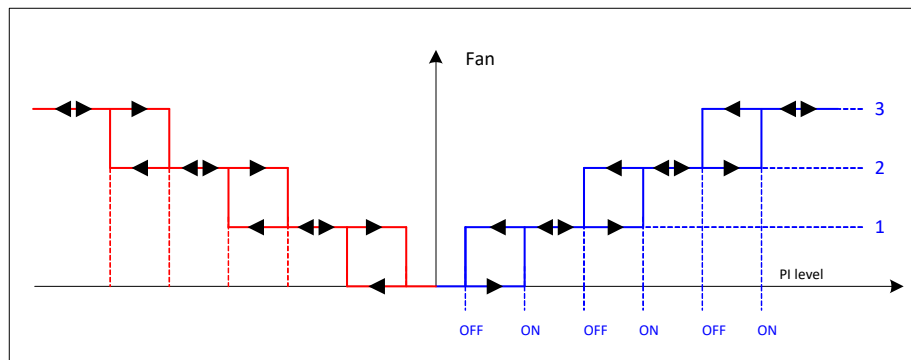

Fig. 20. Multi-speed fan switching depending on control demand

Multi-Speed Fan Settings

For variable-speed fans, the following parameters can be configured in order to determine when the fan switches between the levels dependent on the control demand.

Parameter	Range / Selection	Default
Fan level wiring	Serial Parallel	Serial
Output Speed 1	Any free relay or triac output	
Output Speed 2	Any free relay or triac output	
Output Speed 3	Any free relay or triac output	
Speed 1 Off Cooling Level	0..100, 999 %	0 %
Speed 1 On Cooling Level	0..100, 999 %	5 %
Speed 2 Off Cooling Level	0..100, 999 %	5 %
Speed 2 On Cooling Level	0..100, 999 %	50 %
Speed 3 Off Cooling Level	0..100, 999 %	50 %
Speed 3 On Cooling Level	0..100, 999 %	75 %
Speed 1 Off Heating Level	0..100, 999 %	20 %
Speed 1 On Heating Level	0..100, 999 %	30 %
Speed 2 Off Heating Level	0..100, 999 %	30 %
Speed 2 On Heating Level	0..100, 999 %	60 %
Speed 3 Off Heating Level	0..100, 999 %	60 %
Speed 3 On Heating Level	0..100, 999 %	90 %
Minimum Runtime before On	0..3600 sec	0 sec
Minimum Runtime before Off	0.. 3600 sec	0 sec

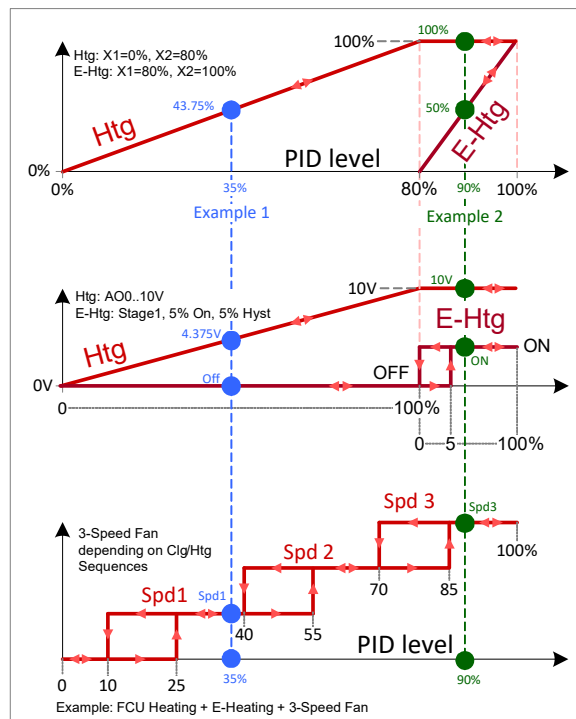

Fig. 21. Multi-speed fan, Heating and E-Heating control Example

Variable-Speed Fan

Variable-Speed Fan Configuration Settings

For variable-speed fans, the following parameters can be configured in order to determine when the fan should switch between the levels dependent on the control demand:

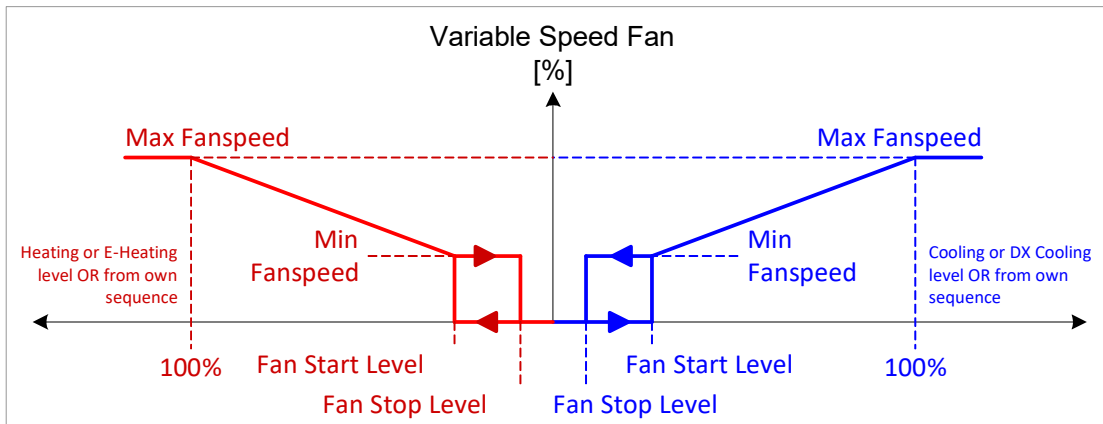

Fig. 22. Variable-speed fan speed depending on control demand

Parameter	Range / Selection	Default
Output Analog Output	Any free analog output	
Output Fanspeed BO	Any free relay or triac output	
Wallmodule Speed 1 Cooling Fanspeed	0..100 %	0 %
Wallmodule Speed 2 Cooling Fanspeed	0..100 %	50 %
Wallmodule Speed 3 Cooling Fanspeed	0..100 %	75 %
Wallmodule Speed 1 Heating Fanspeed	0..100 %	30 %
Wallmodule Speed 2 Heating Fanspeed	0..100 %	60 %
Wallmodule Speed 3 Heating Fanspeed	0..100 %	90 %
Cooling Fan Stop Level	0..100 %	0 %
Cooling Fan Start Level	0..100 %	5 %
Cooling Min Fan Speed	0..100 %	15 %
Cooling Max Fan Speed	0..100 %	100 %
Heating Fan Stop Level	0..100 %	20 %
Heating Fan Start Level	0..100 %	30 %
Heating Min Fan Speed	0..100 %	15 %
Heating Max Fan Speed	0..100 %	75 %

NOTE: The Output Fanspeed BO switches the power supply while the Output Analog Output modulates the fan.

Fan Control Strategy

The fan control strategy can be one of the following:

Depending on cooling and heating sequence (A)

This strategy takes the max. control output of the 4 FCU sequences as fan level. The max. control output is the base percentage level for the multi-speed and variable-speed fans.

Example:

Switch water cooling, then DX-Cooling and use the max. control output of those as fan output.

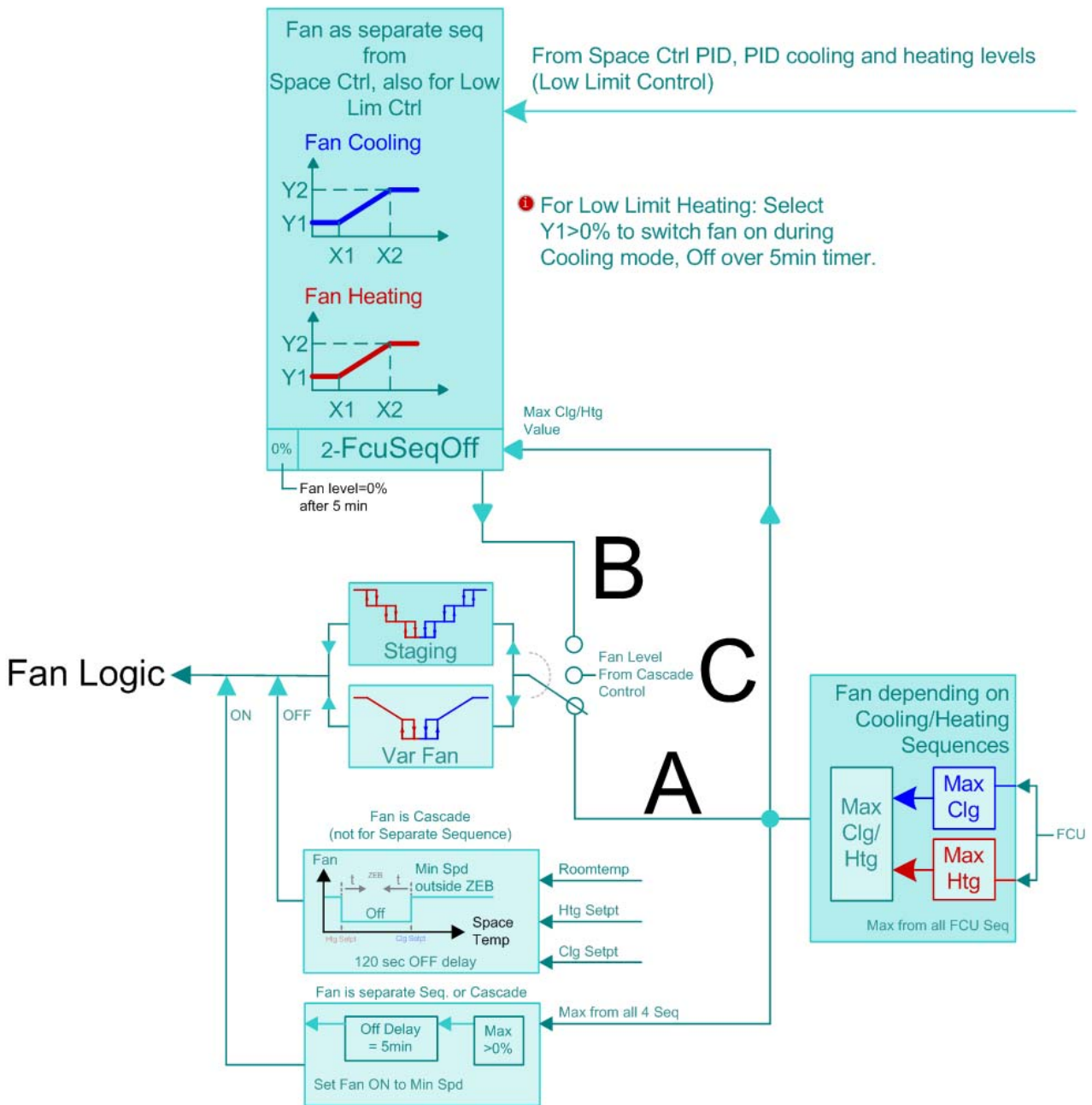

Fig. 23. Fan Control Strategy

Separate PID controlled fan sequence (B)

This strategy takes the PID control output as fan level. The PID control output level allows the sequential execution (X1, X2) for the fan sequence and the cooling / heating sequences. This is the base percentage level for the multi-speed and variable-speed fans.

Example:

First switch fan, then water cooling and then DX-cooling.

Cascade Control Strategy (C)

The fan level is calculated based on the deviation between effective setpoint and current space temperature. The higher the deviation, the higher the fan level. First the setpoint is shifted, then fan speed is increased. This is the base percentage level for the multi-speed and variable speed fans.

Occupancy Optimization

For both multi-speed and variable speed fans, the occupancy modes, the min. and max. speeds can be configured for optimization.

Parameter	Range / Selection	Default
Max Speed during Occ, Byp (0..n Speed, 0..100 %)	0..3 speed	3
Max Speed during Stdbyp (0..n Speed, 0..100 %)	0..3 speed	3
Max Speed during Holiday, Unocc, Byp (0..n Speed, 0..100 %)	0..3 speed	3
Min Speed during Occ, Byp (Low in ZEB) (0..n Speed, 0..100 %)	0..3 speed	0
Min Speed during Stdbyp (Low in ZEB) (0..n Speed, 0..100 %)	0..3 speed	0

Fan Override Settings

For both multi-speed and variable speed fans, the fan speed can be configured for the various advanced conditions such as open window, frost, fire etc. In addition, the following can also be defined:

- fan speed overrun time
- if the fanspeed selection on the wall module should be enabled or disabled.

Parameter	Range / Selection	Default
Window open (0..n Speed, 0..100 %, 999=not used)	0..3 Speed, 0..100 %, 999=not used	999
Space Frost (0..n Speed, 0..100 %, 999=not used)	0..3 Speed, 0..100 %, 999=not used	1
Condensation (0..n Speed, 0..100 %, 999=not used)	0..3 Speed, 0..100 %, 999=not used	999
Fire Alarm (0..n Speed, 0..100 %, 999=not used)	0..3 Speed, 0..100 %, 999=not used	0 %
Wall Module Fanspeed Selection enabled during *1	Standby Occupied, Bypass Occupied, Bypass Holiday, Unoccupied, Standby, Occupied, Bypass Always disabled	Standby Occupied, Bypass
Switch Fan to minimum Speed according Occupancy Mode after PowerUp	No Yes	No
Fanspeed during Night Purge (0..n Speed, 0..100 %, 999=not used)	0..3 Speed, 0..100 %, 999=not used	999
Fanspeed during Overheat (0..n Speed, 0..100 %, 999=not used)	0..3 Speed, 0..100 %, 999=not used	999
Fanspeed during Drip-pan (0..n Speed, 0..100 %, 999=not used)	0..3 Speed, 0..100 %, 999=not used	999
Fan Overrun Time (after closing valve)	0..3600 sec	30 sec

*1 This avoids running the fan over the weekend if the fan is manually commanded to be ON via wall module or BACnet. If the occupancy mode changes to a mode where the fanspeed selection is disabled (e.g. "Unocc"), the fan switches to the AUTO position. On the Sylk WM, the fan selection icon disappears and the user can no longer change the fanspeed. To do so, he first needs to change the occupancy mode to „Override“. Internally, the latest manual fanspeed selection remains in force but it can be reset to AUTO via "WMExtRst". If the occupancy mode changes back (e. g. to "Occ"), then the latest manual fanspeed selection will be active again. This applies in the same way also to conventional wallmodules.

WALL MODULES

Conventional Wall Modules

Wall Module Functions and Types

The following conventional (hard-wired) wall module types are supported:

- Temperature °C
- Temperature °C, Setpoint
- Temperature °C, Setpoint, LED, Button
- Temperature °C, Setpoint, LED, Button, Fan

For corresponding OS numbers and detailed descriptions, please refer to the product data sheets.

Space Temperature Setpoint Adjustments

Typically, the room controller has a wall module with setpoint knob connected to it. When configured, the value from the setpoint knob [WMRmTempSp] is used to adapt the effective setpoint [RmTempEffSp]. There are two options that determine how the setpoint to be used by the control algorithm is calculated: Relative and Absolute. The range of the allowed adjustment is configurable, e.g. +/- 3 K or max. +/-5 K.

*Note it is not possible to configure e.g. -3/+2 (asymmetric)

The space temperature setpoint adjustment can be as follows:

Parameter	Range / Selection	Default
Sensor Input	Any free input	
Setpoint Adjuster [WMRmTempSp]	-5.5 delta K / -10..10 delta °F 12..30 °C / 55..85 °F 0..100 %	-5.5 delta K / -10..10 delta °F
COV Increment	0..10 K	0.25 K

Relative Setpoint Adjustment

When configured to Relative, the wall module setpoint knob [WMRmTempSp] represents a relative offset (typically -5..5 K). The range of the offset can be individually configured for occupied [WM_Sp_Calc_Occ_Sp_Shift_Rng], standby [WM_Sp_Calc_Stby_Sp_Shift_Rng] and unoccupied mode [WM_Sp_Calc_UnOcc_Sp_Shift_Rng].

Typically, the setpoint offset for the unoccupied mode is 0 K to have fix setpoints for building protection. The offset is added to the configured setpoints for the heat and the cool modes.

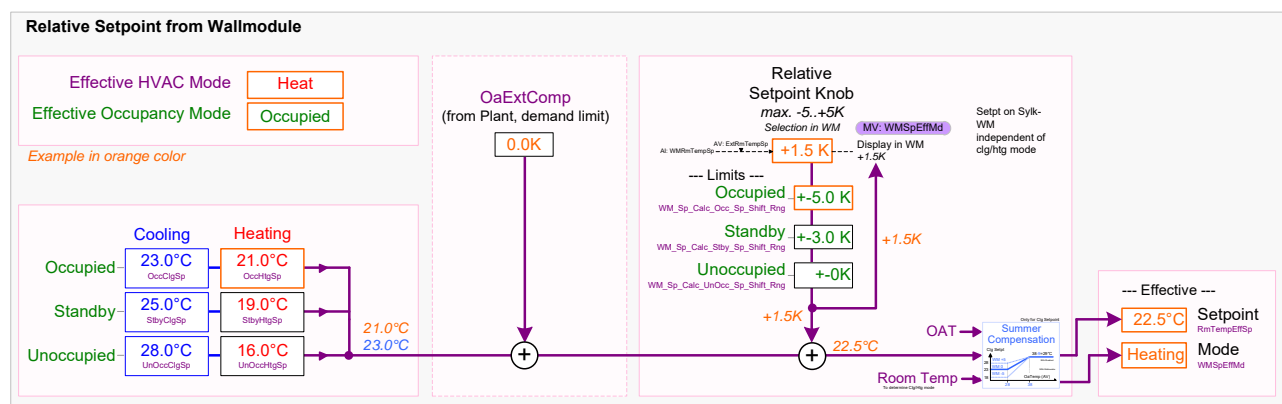

Fig. 24. Relative Setpoint Adjustment

NOTE: The effective setpoint can also be set via BACnet [ExtRmTempSp] with higher priority than the wallmodule. For a Master/Slave application, only the master controller needs the BACnet point.

Absolute Setpoint Adjustment

When configured to Absolute Middle, the setpoint knob [WMRmTempSp] becomes the center of the Zero Energy Band (ZEB) between the cooling and heating occupied or standby setpoints. The range of the ZEB is found by taking the difference between the configured cooling and heating setpoints of the Occupied, standby or unoccupied mode. In cooling mode, the half of the ZEB is added, in heating mode it is subtracted. During Unoccupied modes, the remote setpoint knob is ignored, and the configured setpoints for those modes are used instead.

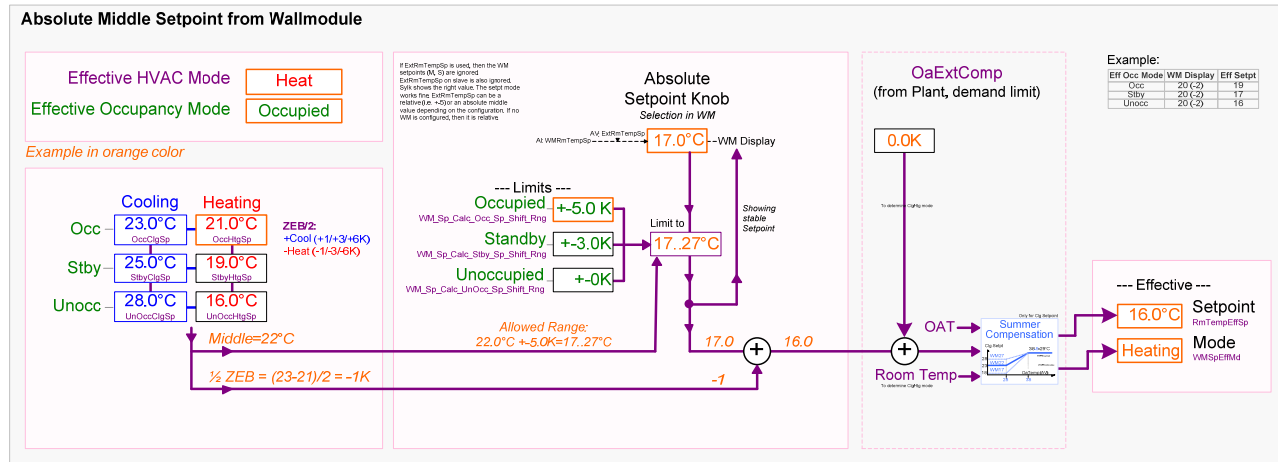

Fig. 25. Absolute Setpoint Adjustment

NOTE: The effective setpoint can also be set via BACnet [ExtRmTempSp] with higher priority than the wallmodule. For a Master/Slave application, only the master controller needs the BACnet point.

Delays and Reset

- Delays** If the ZEB band is small, fast switching (toggling) between heating and cooling mode may occur.
- To reduce toggling, a time delay before cooling / heating mode changes can be configured.
- If the heating setpoint equals the cooling setpoint, then the setpoint toggles permanently between cooling and heating mode.
- The configured time delay cannot avoid this but can improve it.
- To avoid medium mixtures caused by concurrent opened heating and cooling valves, a time delay after cooling - heating mode changes, can be configured. As long as this timer is active, the effective setpoint mode is OFF and as a result all valves are closed.
- Reset** The setpoint adjustment of Sylk wall modules can be reset via plant controller [WMExtRst] in order to avoid heating in the morning after a high setpoint from the day before was selected by the user. This features is recommended for hotels, but also for offices.

Demand Limit Control

Via plant controller, setpoint corrections depending on the outside air temperature can be applied providing the following functions:

- Demand Limit Control
- Increase/Decrease of Space Setpoint

Demand Limit Control

In order to save energy, the space setpoint can be increased in the summer for cooling or decreased over in the winter for heating dependent on the energy consumption BACnet [OaExtComp].

Increase/Decrease of Space Setpoint

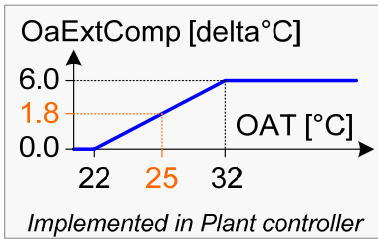

Over a BACnet point [OaExtComp], the plant controller can shift the setpoint in order to save energy or to ensure more comfort during summer or during a strong winter depending on the outside air temperature [OaTemp], see also subsequent section "Summer Compensation".

Summer Compensation

The controller provides a summer compensation depending on the outside air temperature [OaTemp] directly in the IRM controller. In case of high outside air temperature, the space temperature cooling setpoint is gradually increased to avoid a high difference between the outside air temperature and the space temperature. The user cannot compensate the summer compensation via the wallmodule at the highest outside air temperature value.

Example with the default parameters (Increase = 9K [SummerComp_Rst_Rng]):
 OAT = 28°C. The occupied cooling setpoint [RmTempEffSp] of 23°C is not corrected as long as the OAT is <= 28°C.
 OAT = 30°C. The occupied cooling setpoint [RmTempEffSp] of 23°C is increased to 24.2°C.
 OAT = 38°C. The occupied cooling setpoint [RmTempEffSp] of 23°C is increased to 29°C, which is 9K [SummerComp_Rst_Rng] below the outside air temperature. Now the user cannot select a colder setpoint from the wallmodule.

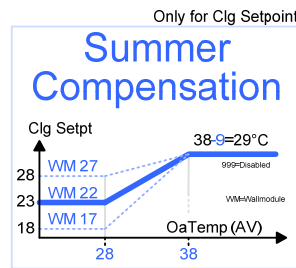
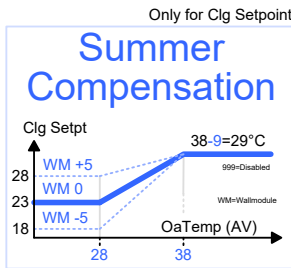

LED Indication Modes

The following tables show the LED behavior dependent on the LED configuration for conventional wall modules. The LED can be configured to indicate either Occupancy modes or Override modes.

Table 1. LED Occupancy Mode Configuration

Occupancy LED	Effective Occupancy Mode
OFF	Unoccupied or Holiday
ON	Occupied or Bypass
Blinking with 1 sec ON, 1 sec OFF	Standby

Table 2. LED Override Mode Configuration

Override LED	Override Mode
OFF	No Override

Override LED	Override Mode
ON	Override to Bypass
Blinking with 1 sec ON, 1 sec OFF	Override to Unoccupied
Blinking with 1 sec ON, 2 sec OFF	Override to Holiday

On-Off / Fanspeed Selection / Button Adjustments

With this option, you assign different wall module hardware functions (depending on the model) to one input. The wall module can provide any or a combination of the following hardware functions:

- bypass button
- on-off switch
- fan speed switch (Auto, 0, 1,2,3)

Parameter	Range / Selection
Sensor Input	Any free input
Operating Mode	Wall module type

The following table shows the equivalent functions configured at the single input.

Function	Bypass Button	On-Off Switch	Fan speed Switch
Auto (On)		x	x
0 / Off		x	x
1 (speed 1)			x
2 (speed 2)			x
3 (speed 3)			x
Button pressed	x	x	x

IMPORTANT!

If a PCD7.L632, Q.RCU-A-TO or Q.RCU-A-TSO wall module is used, then this input is required to read the wall module button, even it is not physically connected to the wall module. This is implemented for compatibility issues with T7460 wall modules.

The hardware wall module functions can also be controlled by using BACnet points:

Wall Module Hardware Function	BACnet Point
Occupancy mode	[ExtOccMd]
HVAC mode	[ExtHVACMd]
Fan speed	[ExtFanManSwCmd]

NOTE: The BACnet points have higher priority than the wall module hardware functions. For a Master/Slave application, only the master controller needs the BACnet points.

Bus-Capable Sylk Wall Modules

Wall Module Functions and Types

The following functions are supported by Sylk wall module types:

- Temperature °C
- Temperature °C, Humidity
- Temperature °C, CO2
- Temperature °C Humidity, CO2
- Temperature °C, Setpoint, Button, Fan
- Temperature °C, Humidity, Setpoint, Button, Fan

- Temperature °C, CO2, Setpoint, Button, Fan
- Temperature °C, Humidity, CO2, Setpoint, Button, Fan
- Temperature °F
- Temperature °F, Humidity
- Temperature °F, CO2
- Temperature °F Humidity, CO2
- Temperature °F, Setpoint, Button, Fan
- Temperature °F, Humidity, Setpoint, Button, Fan
- Temperature °F, CO2, Setpoint, Button, Fan
- Temperature °F, Humidity, CO2, Setpoint, Button, Fan

For corresponding OS numbers and detailed descriptions, please refer to the product data sheets.

Setpoint Adjustments

Please refer to the section "Conventional Wall Modules", p. 52.

Delays and Reset

Please refer to the section "Conventional Wall Modules", p. 52.

OCCUPANCY MODES

A room can be in one of the following basic occupancy modes:

NOTE: The basic mode comes pre-configured from the plant controller as scheduler [OccSch]. When no plant controller is available, the default setting without is Occupied.

- **unoccupied**

no person is in the room; default temperature setpoints = 16 °C (heating) and 28 °C (cooling)

- **standby**

person will be entering the room or has just leaved the room. Energy-saving mode with presence detection; temperature setpoints = 19 °C (heating) and 25 °C (cooling).

- **occupied**

person is in the room; default temperature setpoints = 21 °C (heating) and 23 °C (cooling)

Beside these 3 modes, there are two special mode variants:

- **bypass**

temporary occupied mode initiated by manual override via wall module [MWOccOvrDsp]. Switching can be from scheduled unoccupied or standby to occupied with return to scheduled mode after configurable bypass time [WM_Push_Button_Bypass_Time] has expired or when bypass button is pressed again.

Or, switching can be from occupied to unoccupied until the next schedule change. Recommended in case people leave the area at unpredictable times

Space temperature setpoint [RmTempEffSp] is the same as in occupied mode.

- **holiday**

mode will be switched from scheduled occupied or unoccupied to holiday mode via short press on the wall module bypass button (conventional wall module only). Holiday mode is active until released via next short press of the bypass button or if reset via BACnet. Space temperature setpoint is the same as in unoccupied mode.

For defining the heating and cooling temperature setpoints for the basic occupancy modes, please refer to the section "Space Temperature Setpoints", p. 35.

The effective occupancy mode is available on BACnet [OccMd].

Occupancy Mode Control

The occupancy mode in a room is controlled by the following determining factors:

Scheduler

The plant controller schedule command [OccSch] is the primary determining factor for the occupancy control in the room. For RoomUp, the default setting is "Occupied".

Sensors

Sensors such as the card reader [CardRd] or door contact [Door] and the occupancy sensor [OccSens] detect occupancy triggered by the person in the room. As a result, the occupancy mode [OccSch] changes.

Wall module

Manual overrides executed via wall module [WMOccOvrDsp] will change the occupancy intentionally.

As a result of these determining factors, only one of the 5 occupancy modes (occupied, standby, unoccupied, bypass, or holiday) can be active. The active occupancy mode is called the effective occupancy mode [OccMd].

Sensor Switching Configuration

The switching direction of card readers, door contacts, and occupancy sensors in case of detected presence can be configured. The switching direction is based on the current occupancy mode determined by the scheduler and the switching result is the effective occupancy mode.

One of the following options must be selected:

- Unoccupied/Standby to Occupied:

when scheduler is unoccupied or standby and presence is detected, then the eff. occupancy mode will be occupied

- Standby to Occupied:

when scheduler is standby and presence is detected, then the eff. occupancy mode will be occupied. In case the scheduler tells unoccupied, then switching to occupied is only possible via wall module button.

- Occupied to Standby:

when scheduler is occupied and presence is not detected, then the eff. occupancy mode will be standby.

- Occupied to Unoccupied:

when scheduler is occupied and presence is not detected, then the eff. occupancy mode will be unoccupied

NOTE: One of the last two options are recommended since software need not to distinguish among rooms with and without presence detection (card reader, door contact, or occupancy sensor). If one of the first two options is selected, software need to distinguish among rooms with different presence detection installed which might need, e.g. additional schedules for different rooms.

Effective Occupancy Mode

The following schematic shows the effective occupancy mode as a result of basic schedule settings and switching caused by sensors status or wall module overrides (see diagram on next page).

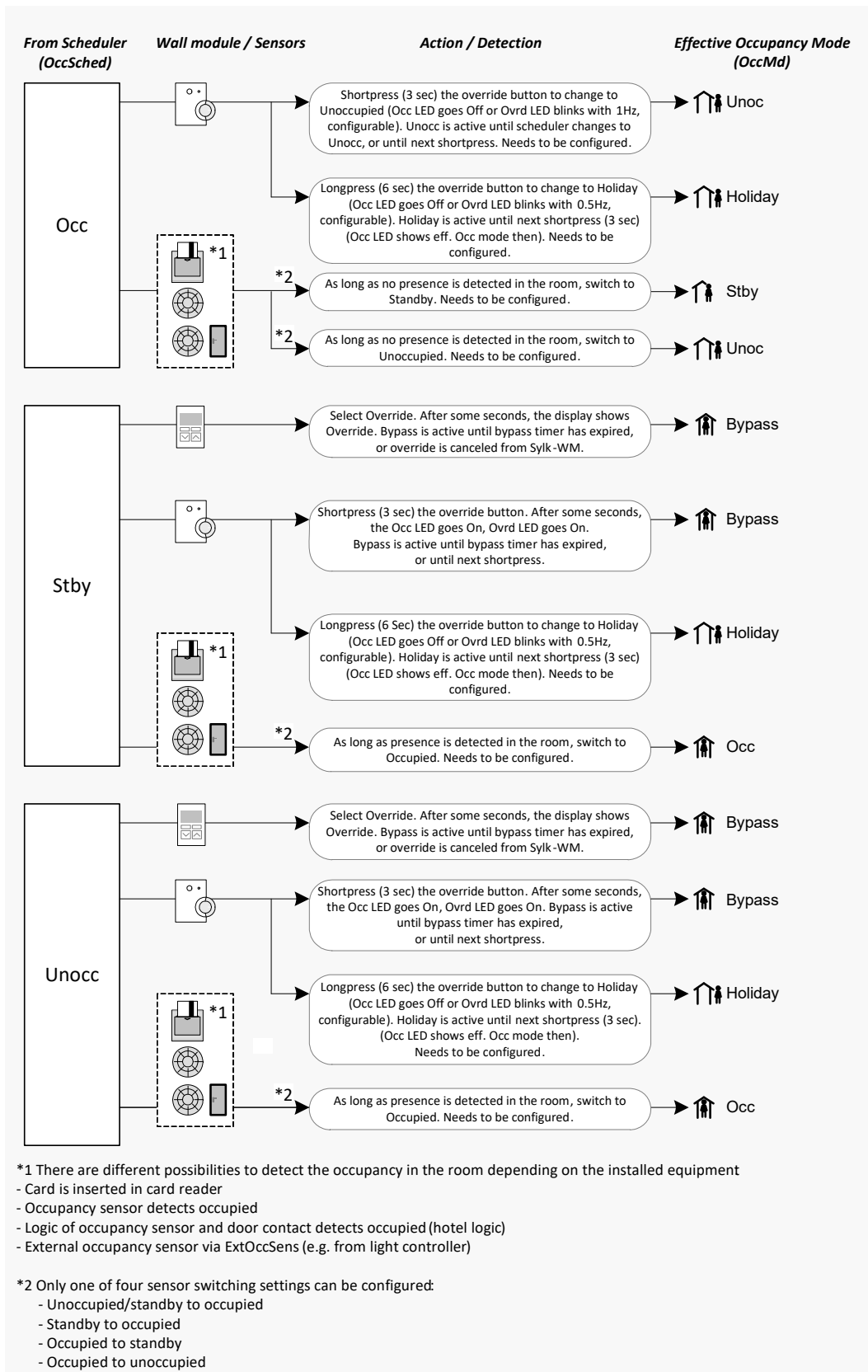

NOTE: According to the schematic, Sylk wall modules do not support manual switch for the Unoccupied and Holiday modes.

The occupancy status is determined based upon the following table:

Table 3. Effective Occupancy Mode Arbitration

Scheduled occupancy mode	Presence detection	Wall module override	Effective occupancy mode
low	← Priority*1 →		high
Occupied	Not assigned	Not assigned	OCCUPIED
Occupied	Occupied	Not assigned	OCCUPIED
Occupied	Unoccupied	Not assigned	STANDBY*2
Occupied	Unoccupied	Not assigned	UNOCCUPIED*2
Occupied	Not assigned	Short press (hard-wired)	UNOCCUPIED
Occupied	Not assigned	Long press (hard-wired)	HOLIDAY
Occupied	Occupied	Short press (hard-wired)	UNOCCUPIED
Occupied	Occupied	Long press (hard-wired)	HOLIDAY*2
Standby	Not assigned	Not assigned	STANDBY
Standby	Occupied	Not assigned	OCCUPIED*2
Standby	Occupied	Not assigned	STANDBY
Standby	Unoccupied	Not assigned	STANDBY
Standby	Not assigned	Override (Syk or short press)	BYPASS
Standby	Not assigned	Override (Long press)	HOLIDAY*2
Standby	Occupied	Override (Syk or short press)	BYPASS or OCCUPIED*2
Standby	Occupied	Override (Long press)	HOLIDAY*2
Unoccupied	Not assigned	Not assigned	UNOCCUPIED
Unoccupied	Occupied	Not assigned	OCCUPIED*2
Unoccupied	Occupied	Not assigned	UNOCCUPIED
Unoccupied	unoccupied	Not assigned	UNOCCUPIED
Unoccupied	Not assigned	Override (Syk or short press)	BYPASS
Unoccupied	Not assigned	Override (Long press)	HOLIDAY*2
Unoccupied	Occupied	Override (Syk or short press)	BYPASS
Unoccupied	Occupied	Override (Long press)	HOLIDAY*2

*1 The BACnet command [ExtOccMd] overrides the effective occupancy mode arbitration logic with highest priority (see section "BACnet Occupancy Override", p. 60).

*2 Based on one of four configurable sensor switching settings:

- Unoccupied/standby to occupied
- Standby to occupied
- occupied to standby (default, recommended)
- Occupied to unoccupied

BACnet Occupancy Override

The active occupancy mode can be overwritten manually via BACnet command [ExtOccMd]. The BACnet command has the highest priority and overwrites the active occupancy mode using one of the following modes:

- Occupied
- Standby
- Unoccupied
- Bypass
- Holiday

FREE INPUTS AND OUTPUTS

The RoomUp supports 20 BACnet objects for free inputs and outputs in total.

These inputs and outputs can be enabled for multiple plant controller functions at the same time up to the limit of the physical hardware inputs and outputs available in the selected controller model.

IMPORTANT!

The availability of free inputs and outputs supported by RoomUp is restricted to the maximum number of 20 BACnet objects although the selected controller hardware may provide more of the corresponding input and/or output types. In contrast, free terminals on the controller may not support the desired function configured in IRM RoomUp. To avoid mismatches, please refer to the tables in the section "Overview of Terminals and Functions", p. 66 for detailed descriptions of the terminals

The max. permissible power output of all 24 VAC terminals is limited, especially if thermal actuators are used. In many cases, external relays are required if multiple thermal actuators need to be connected to one output in parallel. It is strongly recommended to apply the specifications described in the product data, form no. EN0Z-1015GE5.

Free Inputs

The maximum number of free inputs supported by the RoomUp is as follows:

Free Inputs (Universal Inputs)

- 5 Analog Input BACnet objects
- 5 Binary Input BACnet objects
- 2 Accumulator Input BACnet objects

Free Analog Inputs [FreeAI01, FreeAI02, FreeAI03, FreeAI04, FreeAI05]

Depending on the hardware variant, free analog inputs can have the following characteristics:

- 0..10 V
- NTC10 K
- NTC20 K, PT1000

Free analog inputs can be configured with the following settings:

Parameter	Range / Selection	Default
Sensor Input	Any free universal input	Not used
Sensor Type	0..10 V	0..10 V
Characteristic	Direct (0-10 V) = (0-100 %) 0.5-10 V) = (5-100 %)	Direct (0-10 V) = (0-100 %)
Sensor Offset	-100..100 K	0 K
COV Increment	0..100 %	5 %

Parameter	Range / Selection	Default
Sensor Input	Any free universal input	Not used
Sensor Type	NTC 20 K NTC 10 K	NTC 10 K
Sensor Offset	-50..50 K	0 delta K
COV Increment	0..100	0.25 delta K

NOTE: The sensor type depends on the selected sensor input terminal (see Installation and Commissioning Instruction, EN1Z-1015GE51).

Free Binary Inputs [FreeBI01, FreeBI02, FreeBI03, FreeBI04, FreeBI05]

Free binary inputs can be configured with the following settings:

Parameter	Range / Selection	Default
Sensor Input	Any free universal input	Not used

Polarity	Active = Closed Contact (NO) Active = Open Contact (NC)	Active = Closed Contact (NO)
----------	--	------------------------------

Free Accumulator Inputs [FreeACC01, FreeACC02]

Free accumulator inputs can be configured with the following settings:

Parameter	Range / Selection	Default
Sensor Input	Any free universal input	Not used
Scale	$1*(10^{-6})..1*(10^6)$	1
Prescale Multiplier	1..2147483647	1
Prescale Modulo Divide	1..2147483647	1
Max. Pres Value	1.. 2147483647	2147483647
Limit Monitoring Interval (for pulse rate)	1..60	60 sec

Accumulator Usage

Example:

A typical energy meter creates pulses when energy is consumed. In the figure below: 1000 pulses = 1 kWh (1 pulse = 1 Wh). For the BACnet central, it makes no sense to get the values with a resolution of 1 Wh. This resolution also causes high bus traffic.

But, for example, applying 1 decimal place, means that every hundredth pulse is counted by the accumulator (Prescale multiplier/moduloDivide = 1/100). The firmware counts 100 pulses, then it increases the BACnet counter by +1. The BACnet counter is always an integer value, therefore it is not possible to multiply the counter with the „Scale“ inside the room controller. But the scale value is also available at the central and the central can do it. The Counter runs from 0..Max_Pres_Value and then it starts from 0 again.

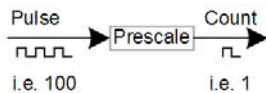

Pulse (M)	Count (N)	N/M divider	Scale (calculated on Plant controller)	Result on IRM controller	Result on Plant controller
1000 Pulses	1	1:1000	1	1/2/3...	1/2/3/... kWh
100 Pulses	1	1:100	0.1	1/2/3...	0.1/0.2/0.3/... kWh
10 Pulses	1	1:10	0.01	1/2/3...	0.01/0.02/0.03/... kWh

It is also possible to measure the electrical power.

For example, the electrical power should be send to the central any 60 sec, then configure Limit_Monitoring_Interval to 60 sec. Every 60 sec, the Pulse_Rate includes the number of pulses.

Example:

Pulse_Rate = 2 -> 2*100 W in 60 sec (0.01666 hour).
 Electrical Power on central: 2 Pulses * 100 * (3600sec/60sec) = 12000 W
 [Pulse_Rate * moduloDivide * (3600/Limit_Monitoring_Interval)]

Free Outputs

The maximum number of free outputs supported by the RoomUp is as follows:

Free Outputs (Analog, Relay, Triac)

- 4 Analog Output BACnet objects
- 4 Binary Output BACnet objects

Free Analog Outputs (Analog, Relay, Triac) [FreeAO01, FreeAO02, FreeAO03, FreeAO04]

Depending on the hardware variant, free analog outputs can have the following characteristics:

- Analog 0/2..10 V
- Floating
- PWM
- Multistate output 1-Stage, 1xBO
- Multistate output 2-Stage, 2xBO
- Multistate output 3-Stage, 2xBO
- Multistate output 3-Stage, 3xBO

1- to 3-Stage Characteristics Usage

These characteristics can be applied in order to sequentially switch on units with multi-staged behavior such as pumps, electric heaters and coolers, fans, etc. It also allows putting out an analog output object with 0..100 % on relays or triacs.

Example: Multistate output 3-Stage, 3xBO Output

- Relay 1 switches at >10 %
- Relay 2 switches at >20 %
- Relay 3 switches at >30 %

Examples: Wiring and Switching Behavior of Multi-Staged Outputs

MSO = multi-state output

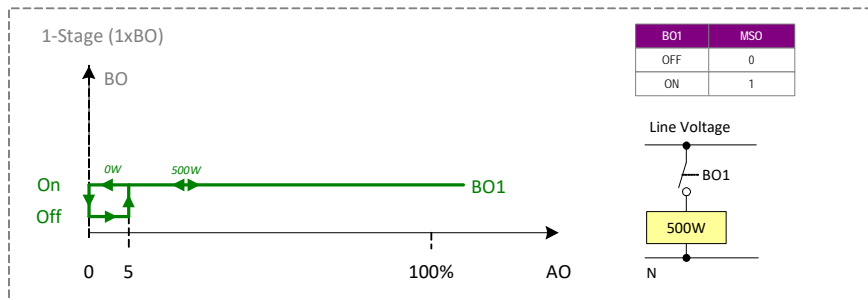

Fig. 26. Free Output: 1-Stage 1xBO

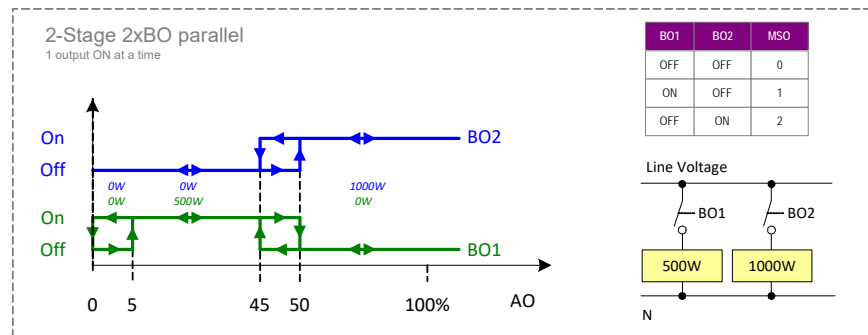

Fig. 27. Free Output: 2-Stage 2xBO parallel

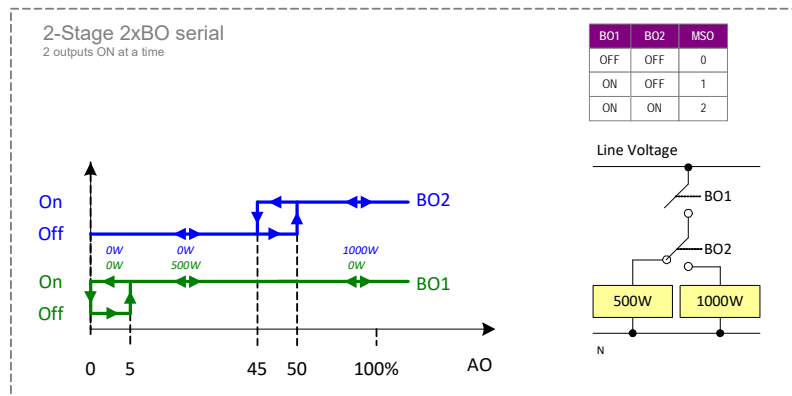

Fig. 28. Free Output: 2-Stage 2xBO serial

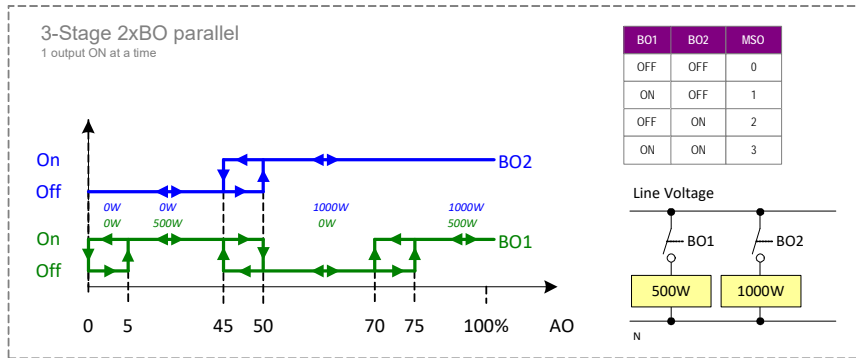

Fig. 29. Free Output: 3-Stage 2xBO parallel

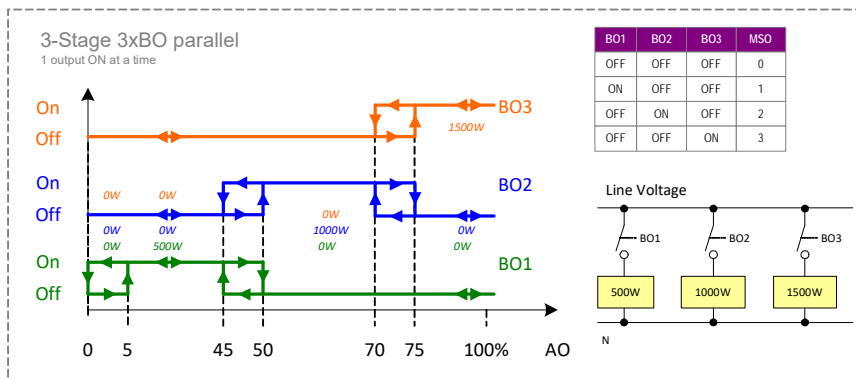

Fig. 30. Free Output: 3-Stage 3xBO parallel

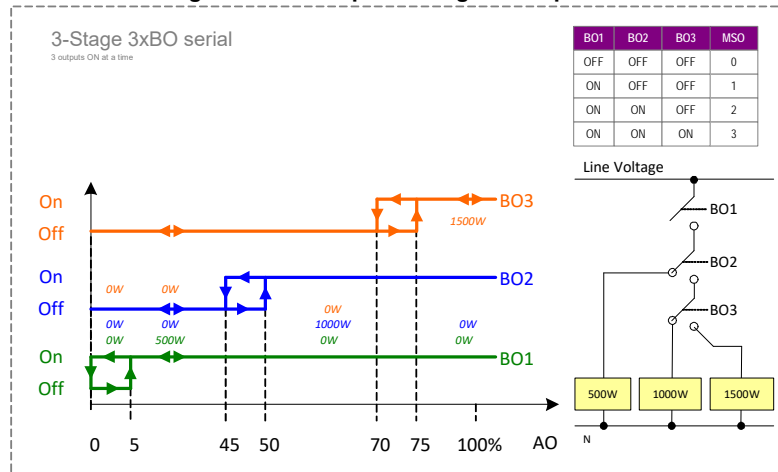

Fig. 31. Free Output: 3-Stage 3xBO serial

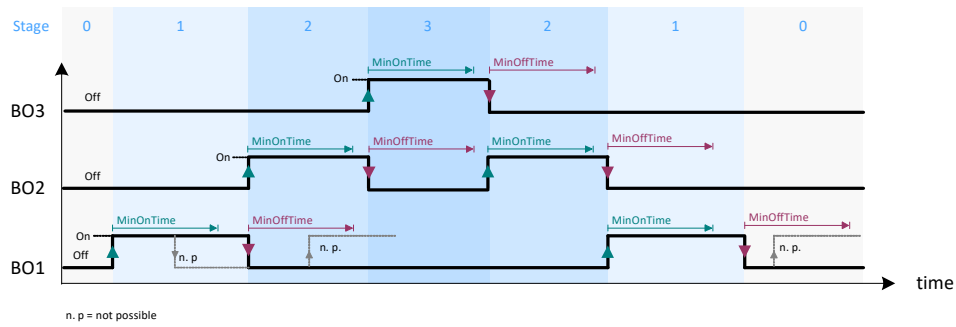

Fig. 32. 3-Stage Output: Min On/Off Time Switching Behavior

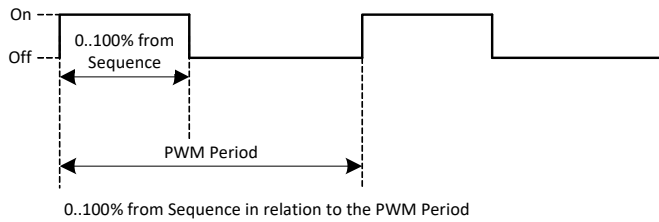

Fig. 33. PWM Output

Binary Outputs [FreeBO01, FreeBO02, FreeBO03, FreeBO04]

Binary outputs can be on triac and relays. Binary outputs are typically used for switching on/off fans depending on the scheduler or a control logic

For detailed settings on inputs and outputs, please refer to the following sections:

- "Sensors", p. 70.
- "Actuators", p. 76.

Room Controller Overview

This chapter describes the main features of the room controller family. For detailed descriptions of the CentraLine room controller family, please refer to the following technical documentation:

- Merlin Room Controller - Product Data, EN0Z-1015GE51
- Merlin Room Controller - Installation and Commissioning Instructions, EN1Z-1015GE51
- Merlin Room Controller - Mounting Instructions, MU1Z-1015GE51

For information on room controllers of other channels, please refer to the relevant technical documentation.

Features

- Designed to control 2- and 4-pipe fan coil units, chilled and hot ceilings, hydronic heating, underfloor heating, intake air for cooling and air quality control, and a mix of these applications.
- Support for 1-3 stage fans, variable fan speed drives (VSDs), thermal, floating, proportional actuators, and 6-way valve actuators.
- Auto Mac-addressing.
- Fast commissioning using plug-and-play solutions, predefined applications and state-of-the-art commissioning via the RoomUp mobile application
- Reduced number of sensors because sensors are shared across different applications.
- BACnet BTL®-Listed as Advanced Application Controllers (B-AAC) rev 1.12.
- Two housing dimensions and several different I/O versions to match your individual needs.
- Universal mounting options, including terminal covers and color-coded terminals.
- Line voltage power supply and the flexible use of relays and triacs (24 VAC or 230 VAC) independent of the line voltage
- 24 VAC aux. output voltage, allowing direct connection and powering of field devices.
- Two-wire polarity-insensitive bus interface to connect to Honeywell Sylk wall modules

Table 4. Room Controller Overview

	Order no.	Svoltage supply	Aos	Uis	Relays	Triacs (24 / 230 VAC)	Total no. of I/Os	24 VAC output for field devices
Large controller (198x110x59 mm)	CLMERL2	230 VAC	2	6	4	4	16	300 mA (or 320 mA for max. 2 minutes)
	CLMERL6	24 VAC	6	10*	4	4	24	300 mA (or 320 mA for max. 2 minutes)
	CLMERL8	230 VAC	6	10*	4	4	24	300 mA (or 320 mA for max. 2 minutes)
	IRM-RLC	Bulk pack with 10 terminal covers						
Small controller (162x110x59 mm)	CLMERS4	230 VAC	4	4	4	2	14	300 mA (or 320 mA for max. 2 minutes)
	CLMERS5	230 VAC	4	4	4	2	14	300 mA (or 320 mA for max. 2 minutes)
	IRM-RSC	Bulk pack with 10 terminal covers						
Commissioning	BACA-A	WiFi Adapter with RJ45 cable						
	CLROOMUP	Android Application						
Wall modules	CLCMTR40, -H, -CO2, -H-CO2							
	CLCMTR42, -H, -CO2, -H-CO2							
	CLCM1T,2T,4T,5T,6T111							
*U11-U14 are binary-only inputs. Of the ten UIs, only two UIs support NTC; this model is thus not suitable for the hardwiring of wall modules requiring three UIs supporting NTC.								

Overview of Terminals and Functions

Table 5. RSxx Room Controller: Overview of terminals and functions

term.	printing	function	RS4	RS5
1, 2	"L", "N"	230-V power supply	X	--
3, 4	"24V~", "24V0"	Aux. output voltage (24 VAC) for all triacs	X	X
5	"TN"	Aux. term. for triac neutral wiring (internally connected with terminal 8)	X	X
6	"T~"	Triac input voltage (24 VAC / 230 VAC) for all triacs; triac-switched	X	X
7	"T01"	Triac-switched output	X	X
8	"TN"	Aux. term. for triac neutral wiring (internally connected with terminal 5)	X	X
9	"T02"	Triac-switched output	X	X
10, 11	"RO4", "IN4"	Output of Relay 4, Input for Relay 4	type 2	type 2
12, 13	"RN", "RN"	Aux. terminals for relay neutral wiring	X	X
14, 15	"IN1", "RO1"	Input for Relay 1, Output of Relay 1	type 1	type 1

term.	printing	function	RS4	RS5
16, 17	"IN2", "RO2"	Input for Relay 2, Output of Relay 2	type 1	type 1
18, 19	"IN3", "RO3"	Input for Relay 3, Output of Relay 3	type 1	type 1
20, 21	"WM1", "WM2"	Removable interface for Sylk Bus	X	X
22, 23, 24, 25	"24V~", "C2+", "C2-", "24V0"	Not used.	--	--
26	"AO1"	Analog Output 1	type 2	type 2
27	"24V~"	24 VAC power for field devices	X	X
28	"GND"	Ground for AOs	X	X
29	"AO2"	Analog Output 2	type 1	type 1
30	"AO3"	Analog Output 3	type 1	type 1
31	"24V~"	24 VAC power for field devices	X	X
32	"GND"	Ground for AOs	X	X
33	"AO4"	Analog Output 4	type 1	type 1
34	"UI1"	Universal Input 1	type 1	type 1
35	"GND"	Ground for UIs	X	X
36	"UI2"	Universal Input 2	type 1	type 1
37	"UI3"	Universal Input 3	type 1	type 1
38	"GND"	Ground for UIs	X	X
39	"UI4"	Universal Input 4	type 1	type 1
40, 41, 42	"C1+", "C1-", "GND"	Removable BACnet MS/TP interface and corresponding GND	X	X
Relay output types: See Table 7. Relay output types and characteristics. Universal input types: See Table 8. Universal input types and characteristics. Analog output types: See Table 9. Analog output types and characteristics.				

Table 6. RLxx Room Controllers: Overview of terminals and functions (by model)

term.	printing	function	RL2	RL6	RL8
1, 2	"L", "N"	230-V power supply	X	--	X
3, 4	"24V~", "24V0"	Not used.	--	X	--
5, 6	"24V~", "24V0"	Aux. output voltage (24 VAC) for all triacs	X	X	X
7	"TN"	Aux. terminal for triac neutral wiring (internally connected with terminals 10 + 13)	X	X	X
8	"T~"	Triac input voltage (24 VAC / 230 VAC) for all triacs; triac-switched	X	X	X
9	"T01"	Triac-switched output	X	X	X
10	"TN"	Aux. terminal for triac neutral wiring (internally connected with terminals 7 + 13)	X	X	X
11	"T02"	Triac-switched output	X	X	X
12	"T03"	Triac-switched output	X	X	X
13	"TN"	Aux. terminal for triac neutral wiring (internally connected with terminals 7 + 10)	X	X	X
14	"T04"	Triac-switched output	X	X	X
15	"RC4"	Not used.	--	--	--
16, 17	"RO4", "IN4"	Output of Relay 4, Input for Relay 4	type 2	type 2	type 2
18	"RN"	Aux. terminal for relay neutral wiring	X	X	X
19	"RN"	Aux. terminal for relay neutral wiring	X	X	X
20, 21	"IN1", "RO1"	Input for Relay 1, Output of Relay 1	type 2	type 2	type 2
22, 23	"IN2", "RO2"	Input for Relay 2, Output of Relay 2	type 1	type 1	type 1
24, 25	"IN3", "RO3"	Input for Relay 3, Output of Relay 3	type 1	type 1	type 1
26, 27, 28,	"C2+", "C2-",	Not used.	--	--	--

term.	printing	function	RL2	RL6	RL8
29	"24V0", "24V~"				
30, 31	"WM1", "WM2"	Removable interface for Sylk Bus	X	X	X
32	"AO1"	Analog Output 1	type 3	type 3	type 4
33	"GND"	Ground for AOs	X	X	X
34	"AO2"	Analog Output 2	type 3	type 3	type 3
35	"24V~"	24 VAC power for field devices	X	X	X
36	"AO3"	Analog Output 3	--	type 1	type 5
37	"GND"	Ground for AOs	--	X	X
38	"AO4"	Analog Output 4	--	type 1	type 5
39	"24V~"	24 VAC power for field devices	--	X	X
40	"AO5"	Analog Output 5	--	type 1	type 1
41	"GND"	Ground for AOs	--	X	X
42	"AO6"	Analog Output 6	--	type 1	type 1
43	"24V~"	24 VAC power for field devices	--	X	X
44	"24V~"	24 VAC power for field devices	X	--	X
45	"LED"	Output to LED of CLCM4T,5T,6T111	X	--	X
46	"GND"	Ground for UIs	X	X	X
47	"UI1"	Universal Input 1	type 1	type 1	type 3 (BI)
48	"UI2"	Universal Input 2	type 1	type 1	type 3 (BI)
49	"GND"	Ground for UIs	X	X	X
50	"UI3"	Universal Input 3	type 1	type 1	type 3 (BI)
51	"UI4"	Universal Input 4	type 1	type 1	type 3 (BI)
52	"GND"	Ground for UIs	X	X	X
53	"UI5"	Universal Input 5	type 1	type 1	type 1
54	"UI6"	Universal Input 6	type 1	type 1	type 1
55	"GND"	Ground for UIs	X	X	X
56	"UI7"	Universal Input 7	--	type 2	type 2
57	"UI8"	Universal Input 8	--	type 2	type 2
58	"GND"	Ground for UIs	--	X	X
59	"UI9"	Universal Input 9	--	type 2	type 2
60	"UI10"	Universal Input 10	--	type 2	type 2
61	"GND"	Ground for UIs	--	X	X
62, 63, 64	"C1+", "C1-", "GND"	Removable BACnet MS/TP interface and corresponding GND	X	X	X
Relay output types: See Table 7. Relay output types and characteristics. Universal input types: See Table 8. Universal input types and characteristics. Analog output types: See Table 9. Analog output types and characteristics..					

Table 7. Relay output types and characteristics

	type 1 (standard)	type 2 (high in-rush current)
corresponding ROs of RSxx	RO1, RO2, RO3	RO4
corresponding ROs of RLxx	RO2, RO3	RO1, RO4
contact	N.-O.	N.-O.
min. load	5 VAC, 100 mA	24 VAC, 40 mA
switching voltage range	15 ... 253 VAC	15 ... 253 VAC
max. continuous load at 250 VAC (cos φ = 1)	4 A	10 A
max. continuous load at 250 VAC (cos φ = 0.6)	4 A	10 A
in-rush current (20 ms)	--	80 A
usage	fan motor	light switching and fan motor

NOTE: The max. sum load of all relay currents at the same time is 14 A

Table 8. Universal input types and characteristics

	type 1	type 2	type 3
	UI1, UI2, UI3, UI4, UI5, UI6	UI7, UI8, UI9, UI10	UI1, UI2, UI3, UI4 (RL8, only)
dry contact (closed: res. <10 kΩ; open: res. > 20 kΩ; max. 0.2 Hz; pull-up voltage: 10 V)	X	X	--
dry contact (closed: res. <10 kΩ; open: res. > 20 kΩ; max. 0.2 Hz; pull-up voltage: 24 V)	--	--	X
fast binary (=counter) input (max. 30 Hz; pulse ON = min. 16 ms; pulse OFF = min. 16 ms; closed: voltage < 1 V; open: voltage > 5 V; pull-up voltage: 10 V)	X	X	--
fast binary (=counter) input (max. 30 Hz; pulse ON = min. 16 ms; pulse OFF = min. 16 ms; closed: voltage < 1 V; open: voltage > 5 V; pull-up voltage: 24 V)	--	--	X
0(2) ... 10 V	X	X	--
NTC20kΩ	X	--	--
Button, Setpoint and Fanspeed Switch (from CLCM1T,2T,4T,5T,6T111)	X	--	--
NTC10kΩ	X	--	--
PT1000 + Ni1000TK5000	--	X	--

Table 9. Analog output types and characteristics

	type 1	type 2	type 3	type 4	type 5
output voltage	0...11 V				
output current	0...1 mA	0...5 mA	0...10 mA	0...20 mA	-1...+1 mA
min. accuracy	±150 mV				
max. ripple	±100 mV				
accuracy at zero point	0...200 mV				±150 mV

SENSORS

In the following sections, the sensors with their properties are described. Most of the sensors are also available over BACnet.

Air Quality Sensor



This sensor [RmCO2.PresentValue] measures the CO2 concentration in ppm.

Parameter	Range / Selection	Default
Sensor Input	Any free input	
Sensor Type	0..10 V	0..10 V
Characteristics	0.5..10 V (5-100 %) 0..10 V (0-3000 ppm) 0..10 V (0-2000 ppm)	0.5..10 V (5-100 %)
Sensor Offset [RmCO2.SensorOffset]	-500..+500 ppm, %	0 ppm, %
COV Increment	0..500 ppm, %	25 ppm, %
Enable Alarm and Event Notification	Off On	Off-
Reliability	No sensor, open, short, no fault	no fault

NOTE: This sensor is also available via BACnet [ExtRmCO2] with higher priority than the hardwired sensor. For a Master/Slave application, only the master controller needs the BACnet sensor.

Ceiling Cold Water Temperature Sensor



This sensor [CeilWtrTemp.PresentValue] measures the temperature of the cold water at the input of the chilled ceiling pipe.

Parameter	Range / Selection	Default
Sensor Input	Any free input	
Sensor Type	NTC 20 K NTC 10 K	NTC 20 K
Sensor Offset [CeilWtrTemp.SensorOffset]	-10..10 K	0 K
COV Increment	0..10 K	0.25 K
Enable Alarm and Event Notification	Off On	Off
Reliability	No sensor, open, short, no fault	no fault

FCU Discharge Temperature Sensor



This sensor [SaTemp.PresentValue] measures the temperature of the air supplied to the room by the FCU.

Parameter	Range / Selection	Default
Sensor Input	Any free input	
Sensor Type	NTC 20 K	NTC 20 K

Parameter	Range / Selection	Default
	NTC 10 K	
Sensor Offset [SaTemp.SensorOffset]	-10..10 K	0 K
COV Increment	0..10 K	0.25 K
Enable Alarm and Event Notification	Off On	Off
Reliability	No sensor, open, short, no fault	no fault

Cool / Heat Changeover Temperature

This sensor measures the temperature of the supply water for the 2-pipe changeover application. The sensor has higher priority than received from the Plant controller [PltCngOvrWtrTemp].

Parameter	Range / Selection	Default
Sensor Input	Any free input	
Sensor Type	NTC 20 K NTC 10 K	NTC 20 K
Sensor Offset [PltCngOvrWtrTemp.SensorOffset]	-10..10 K	0 K
COV Increment	0..10 K	0.25 K
Enable Alarm and Event Notification	Off On	Off
Reliability	No sensor, open, short, no fault	no fault

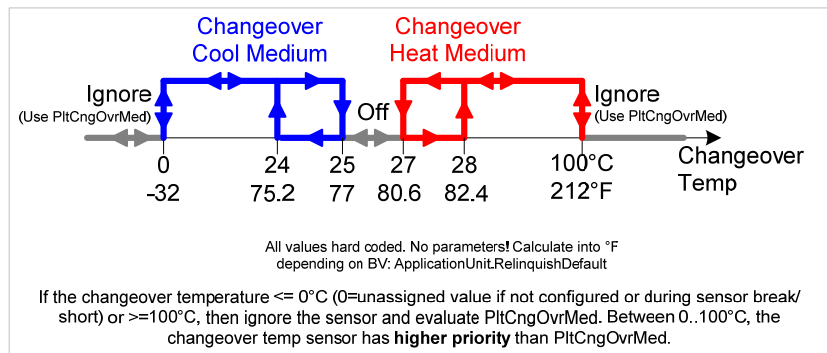

Fig. 34. Cooling / Heating Changeover Temperature Sensor Behavior

Humidity Sensor



This sensor [RmRH.PresentValue] is typically included in the wall module and measures the humidity in the room.

Parameter	Range / Selection	Default
Sensor Input	Any free input	
Sensor Type	0..10 V	0..10 V
Characteristic	0.5-10 V (5-100 %)	0.5-10 V (5-100 %)
Sensor Offset [RmRH.SensorOffset]	-50..50 %	0 %

Parameter	Range / Selection	Default
COV Increment	0..50 %	5 %
Enable Alarm and Event Notification	Off On	Off

NOTE: A filter is always activated independent of the location to reduce permanent valve/damper movement.

NOTE: This sensor is also available via BACnet [ExtRmRH] with higher priority than the hardwired sensor. For a Master/Slave application, only the master controller needs the BACnet sensor.

Intake Air Temperature Sensor



This sensor [IntakeDmprTemp.PresentValue] measures the temperature of the supply air in the air duct.

Parameter	Range / Selection	Default
Sensor Input	Any free input	
Sensor Type	NTC 20 K NTC 10 K	NTC 20 K
Sensor Offset [IntakeDmprTemp.SensorOffset]	-10..10 K	0 K
COV Increment	0..10 K	0.25 K
Enable Alarm and Event Notification	Off On	Off
Reliability	No sensor, open, short, no fault	no fault

Radiator Radiation Temperature Sensor



This sensor [RadRadiTemp.PresentValue] measures the temperature of the air at the front above the radiator.

Parameter	Range / Selection	Default
Sensor Input	Any free input	
Sensor Type	NTC 20 K NTC 10 K	NTC 20 K
Sensor Offset [RadRadiTemp.SensorOffset]	-10..10 K	0 K
COV Increment	0..10 K	0.25 K
Enable Alarm and Event Notification	Off On	Off
Reliability	No sensor, open, short, no fault	no fault

Space Temperature Sensor



This sensor [RmTemp.PresentValue] can be a NTC10K or NTC20K type and measures the space temperature. Beside this common function, the space temperature sensor is also used for frost protection and overheat protection of the room.

Parameter	Range	Default
Frost space temperature	-50..150 °C	8 °C

Parameter	Range	Default
[RmFrostSp.RelDefault]		
Frost hysteresis	0.25..100 K	1 K
Overheat space temperature [RmOvrHtgSp.RelDefault]	-50..150 °C	35 °C
Overheat hysteresis	0.25..100 K	1 K
Sensor Offset [RmTemp.SensorOffset]	-10..10 K	0 K
COV Increment	0..10 K	0,25 K
Enable Alarm and Event Notification	Off On	Off
Reliability	No sensor, open, short, no fault	no fault

NOTE: For BACnet alarming and sensor failure behavior, please refer to the section "Alarming", p. 87.

NOTE: This sensor is also available via BACnet [ExtRmTemp] with higher priority than the hardwired sensor. For a Master/Slave application, only the master controller needs the BACnet sensor.

Underfloor Heating Temperature Sensor



This sensor [UnFlrSupWtrTemp.PresentValue] measures the temperature of the water at the input of the underfloor heating pipe.

Parameter	Range / Selection	Default
Sensor Input	Any free input	
Sensor Type	NTC 20 K NTC 10 K	NTC 20 K
Sensor Offset [UnFlrSupWtrTemp.SensorOffset]	-10..10 K	0 K
COV Increment	0..10 K	0.25 K
Reliability	No sensor, open, short, no fault	no fault

Airflow Sensor



This sensor [AirFlow] measures whether the fan of the FCU is running or not.

Parameter	Range / Selection	Default
Sensor Input	Any free input	
Polarity	Airflow = Closed contact (NO) Airflow = Open contact (NC)	Airflow = Closed contact (NO)
Air Flow Off Hold Time	3600 sec	2 sec

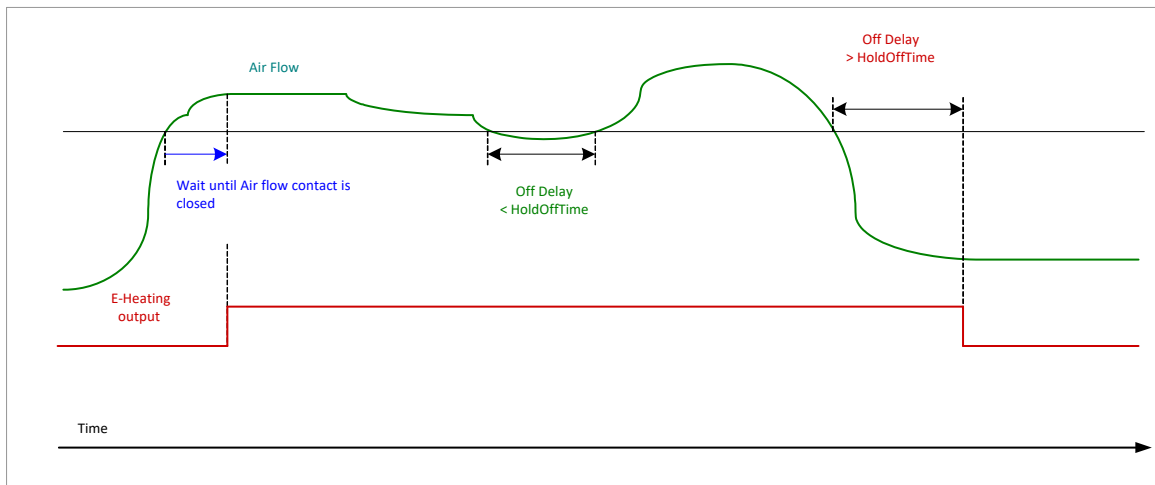

Fig. 35. Example: E-Heating

The airflow sensor can be enabled or disabled individually for each of the 4 outputs: cooling, heating, DX-cooling and E-heating. If enabled, each output shows the following behavior:

If the airflow is missing for a time greater than the Air Flow Off Hold Time (configurable, default 2 sec), then the corresponding actuator (output) is closed (Off). The fan output remains On. There is no need to reset the failure locally. In case of a master/slave system, the airflow sensor is evaluated on each slave, that means, if no airflow is detected on the master or on the slave, all other controllers keep running.

Card Reader



This sensor [CardRd] measures the occupancy or unoccupancy of a person in the room. Occupancy is indicated by the inserted card. Unoccupancy is indicated when the card is removed.

Parameter	Range / Selection	Default
Sensor Input	Any free input	
Polarity	Occupied = Closed contact (NO) Occupied = Open contact (NC)	Occupied = Closed contact (NO)

Condensation



This sensor [Cond] measures whether condensation on the chilled ceiling has occurred or not.

Parameter	Range / Selection	Default
Sensor Input	Any free input	
Polarity	Condensation = Closed contact (NO) Condensation = Open contact (NC)	Condensation = Closed contact (NO)

Door Contact



This sensor [Door] signals the opening and closing of a door.

Parameter	Range / Selection	Default
Sensor Input	Any free input	
Polarity	Door Open = Closed contact (NO) Door Open = Open contact (NC)	Door Open = Closed contact (NO)

Drip-Pan Contact



This sensor [DripPan] signals whether the collected water in the drip pan underneath the FCU has reached the max. level or not.

Parameter	Range / Selection	Default
Sensor Input	Any free input	
Polarity	Drip Pan Alarm = Closed contact (NO) Drip Pan Alarm = Open contact (NC)	Closed contact (NO)

Occupancy Sensor



This sensor [OccSens] measures the occupancy or unoccupancy of a person in the room.

Parameter	Range / Selection	Default
Sensor Input	Any free input	
Polarity	Occupied = Closed contact (NO) Occupied = Open contact (NC)	Occupied = Closed contact (NO)

NOTE: This sensor is also available via BACnet [ExtOccSens] with an OR-Logic together with the hardwired sensor. For a Master/Slave application, only the master controller needs the BACnet sensor.

Window Contact



This sensor [Window] signals the opening and closing of a window.

Parameter	Range / Selection	Default
Sensor Input	Any free input	
Polarity	Window Open = Closed contact (NO) Window Open = Open contact (NC)	Window Open = Closed contact (NO)

NOTE: This sensor is also available via BACnet [ExtWindow] with an OR-Logic together with the hardwired sensor. For a Master/Slave application, only the master controller needs the BACnet sensor.

ACTUATORS

Actuator Types

The application supports a variety of actuators as shown in the following table.

Table 10. Supported Actuators

Supported actuators / Application	Analog 0/2...10 V	Floating	PWM	1-Stage (Rel, Tr)	2-Stage, 3-Stage	6-way MID valve 0...10 V	On / Off (Rel, Tr)
FCU Cooling	X	X	X	X	--	X	--
FCU Heating	X	X	X	X	--	X	--
FCU DX-Cooling	--	--	X	X	X	--	--
FCU E-Heating	--	--	X	X	X	--	--
Ceiling Cooling	X	X	X	X	--	X	--
Ceiling Heating	X	X	X	X	--	X	--
Ceiling Switch over 2-way Cooling	--	--	--	--	--	--	X
Ceiling Switch over 2-way Heating	--	--	--	--	--	--	X
Ceiling Switch over 3-way	--	--	--	--	--	--	X
Radiator Heating	X	X	X	X	--	--	--
Underfloor Heating	X	X	X	X	--	--	--
Intake Air	X	X	--	--	--	--	X
FreeAO	X	X	X	X	X	--	--
FreeBO	--	--	--	--	--	--	X

Weekly Exercising

To prevent the valve from sticking, the actuators 0/2..10 V, Floating, and PWM support an optional weekly exercising. If the valve position is stable for 1 week, then weekly exercising is activated (BACnet property 1024 = 1). A valve with a position <50% is opened, a valve with a position >50% is closed for a fix runtime as described in the Actuator table below.

Analog 0/2..10 V Actuator

The following parameters can be set for analog 0/2..10 V actuators:

Parameter	Range / Selection	Default	Remark
Output	Any free analog output		
Characteristic	Direct (0-10V) = (0-100 %) Reverse (0-10V) = (100-10 %) Direct (2-10V) = (0-100 %) Reverse (2-10V) = (100-10 %)	Direct (0-10V) = (0-100 %)	
Weekly Exercising	Enabled/Disabled	Disabled	Weekly fully open or close for 150 sec

Floating Actuator

Floating actuators use two outputs, one for opening and one for closing the valve. The outputs can be relays or triacs. The characteristic can be direct or reverse.

The parameters can be set as follows:

Parameter	Range / Selection	Default	Remark
Output for Close	Any free relay or triac output		
Output for Open	Any free relay or triac output		
Characteristic	Direct (0-10V) = (0-100 %) Reverse (0-10V) = (100-0 %)	Direct (0-10V) = (0-100 %)	
Weekly Exercising	Enabled/Disabled	Disabled	Weekly fully open or close for 150 sec
Direct Open Runtime Reverse Close Runtime	0..3600 sec	150 sec	
Direct Close Runtime Reverse Open Runtime	0..3600 sec	150 sec	
Valve Hysteresis	0.5..20 %	1 %	Hysteresis x Runtime >500 msec
Power-Up Synchronization	Direct Power-Up Synchronization Reverse Power-Up Synchronization Disabled	Direct Power-Up Synchronization	Option type must be selected according to characteristic choice
Synchronization	Direct - Sync to Close Position Reverse - Sync to Close Position Sync to Close and Open Position	Direct - Sync to Close Position	Option type must be selected according to characteristic choice
Repeat above synchronization in closed/open position with 10 % runtime any	0..86400 sec	3600 sec	
Number of repeated synchronization in closed/open position with 10 % runtime any	0..10	3	0= not used

PWM Actuators

For PWM actuators, the output can be a triac only. The characteristic can be direct or reverse and the PWM period can be defined.

The parameters can be set as follows:

Parameter	Range / Selection	Default	
Output	Any free triac output		
Characteristic	Direct (0-10V) = (0-100 %) Reverse (0-10V) = (100-10 %)	Direct (0-10V) = (0-100 %)	
Weekly Exercising	Enabled/Disabled	Disabled	Weekly fully open or close for 150 sec
PWM Period	0..3600 sec	150 sec	

Staged Actuators

Analog Outputs

The following parameters can be set for analog staged outputs:

Parameter	Range / Selection	Default
Free AO Type	1-Stage, 1xBO 2-Stage, 2xBO 3-Stage, 2xBO 3-Stage, 3xBO	Not used
Mode	Parallel (only one output ON at a time) Serial (several outputs ON at a time)	Parallel (only one output ON at a time)
Output 1	Any free relay or triac output	

Parameter	Range / Selection	Default
Output 2	Any free relay or triac output	
Output 3	Any free relay or triac output	
Stage 1	0..100 %	5 %
Stage 2	0..100 %	50 %
Stage 3	0..100 %	75 %
Stage Hysteresis	0..100 %	5 %
Min Off Time	0..3600 sec	0 sec
Min On Time	0..3600 sec	0 sec

Note: A Stage output is on BACnet an „Analog Output“ Type acting as a binary output.

On/Off Actuators

Binary Outputs

Binary outputs can be on triac and relays. On/Off uses other parameters than Stage1, see below table.

Parameter	Range / Selection	Default
Output Type	On/Off	Not used
Output	Any free relay or triac output	
Polarity	Direct Reverse	Direct
On/Off Level For Intake Air only	0..100%	5%
On/Off Hysteresis for Intake Air only	0..100%	5%

NOTE: The BACnet point type for “Ceiling Switch over 2-way“ and “Ceiling Switch over 3-way“ are Binary Outputs, while Intake Air is an „Analog Output“.

6-Way MID Valve

This output type will be used for FCU and ceiling applications. The following parameters can be set for the 6-Way MID Valve output:

Parameter	Range / Selection	Default
Output	AO	Not used
Sequence 1/2	Seq1 = Cooling, Seq2 = Heating Seq1 = Heating, Seq2 = Cooling	Seq1 = Cooling, Seq2 = Heating
Sequence 1 start voltage level of fully angle		2 V
Sequence 1 end voltage level of fully angle		4.7 V
Sequence 2 start voltage level of fully angle		7.3 V
Sequence 2 end voltage level of fully angle		10 V

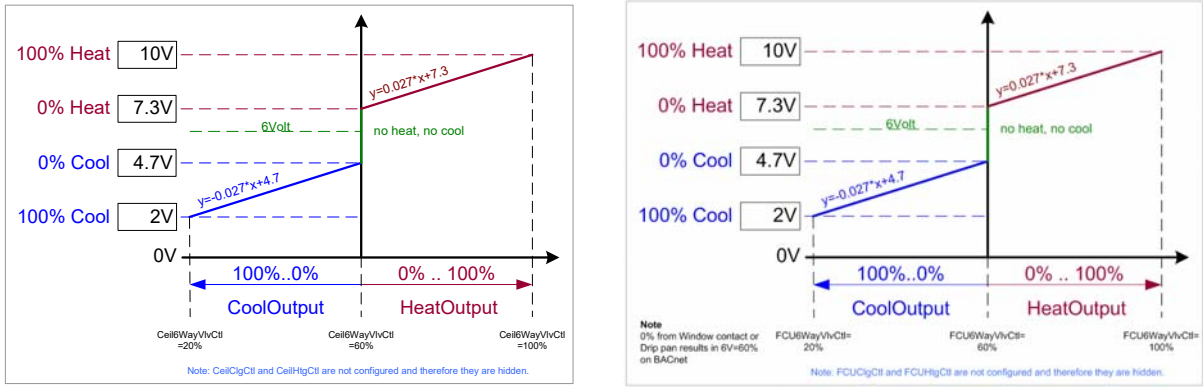

Fig. 36. 6-Way Valve output for Cooling and Heating

MASTER-SLAVE CONTROLLERS

System Architecture

The IRM master/slave system architecture is specified as follows:

- Max. 30 controllers on a single MS/TP channel
- Max. 15 master controllers with 1 slave controller
- 1 master controller with max. 29 slave controllers
- 600..650 updates/min for all controllers
- Master and slave controller must have the same firmware and bootloader versions
- Master and slave controller must have the same application version (e.g. IRM_H_0005)
- The master controller must have the entire plant configured while the slave can include only a subset of the master's configuration
- Limitations at 38400 baud

Bus Load

In order to avoid a bus overload, it is strongly recommended to disable those master-slave functions that are not configured in the application (see section "Communication and Value Aggregation", p. 81).

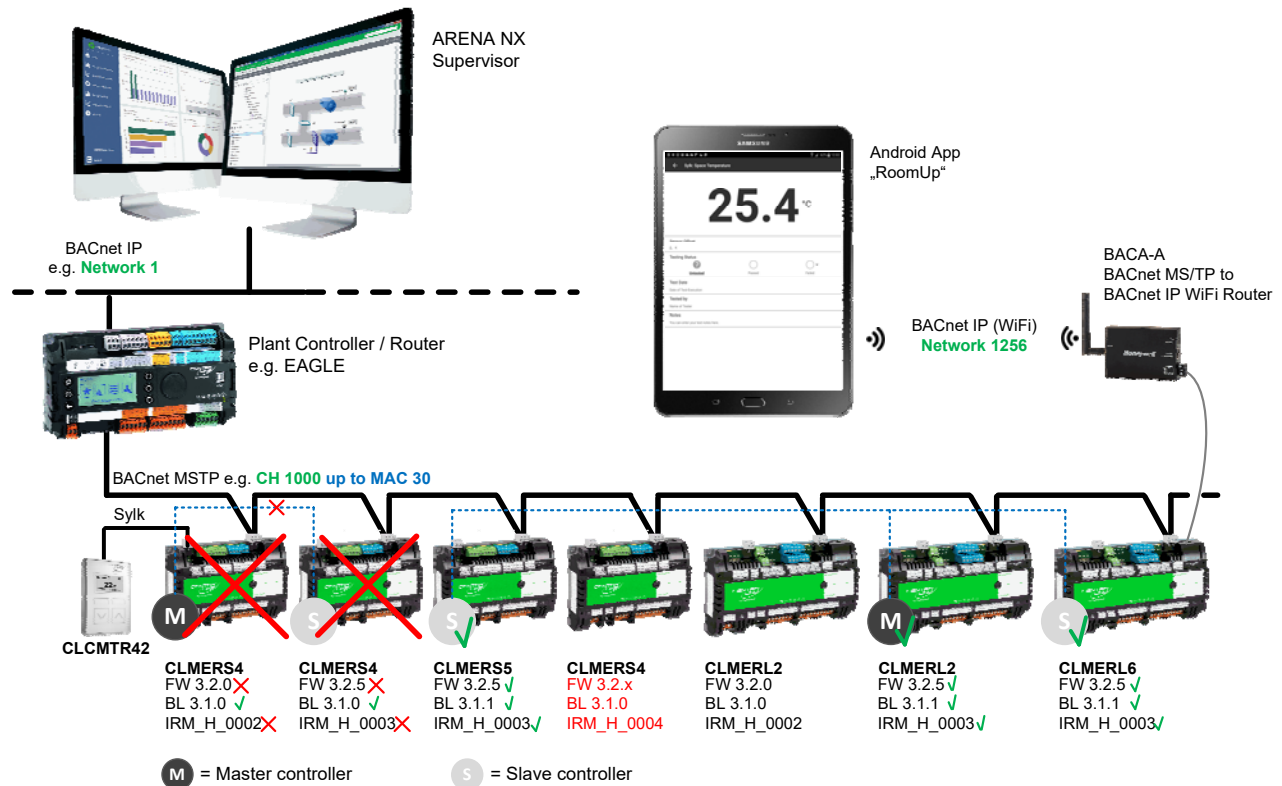

Fig. 37. Master-Slave System Architecture

Functional Description

Common Temperature Control

When one or more room controllers serve a common area, a master/slave arrangement can be configured. One room controller is configured as master. The other room controller(s) will be configured as slave(s). The master controller and the slave controllers communicate via certain BACnet points. Both controllers, the master and any slave controller, can have a Sylk wall module assigned. When using conventional wall modules, only the master controller can have one wall module assigned.

The master controller monitors the sensors, contacts and wall modules (except conventional wall modules at slaves) installed on itself and on the slave controller(s). The master controller uses this information to determine the effective control mode,

occupancy mode and setpoint mode before it calculates the control output for heating and cooling stages. Then the master controller broadcasts the calculated control output for each heating and cooling stage to the slave controller(s).

NOTE: The master controller must include all functions of the slave controller but the slave controller need not to have all functions of the master controller included.

Examples:

If the slave controller is configured with intake air, then the master controller must also be configured for intake air. Vice versa this is not the case.

If the master controller is configured with underfloor heating and the slave controller is configured with radiator heating, radiator heating must also be configured on the master controller. The slave controller can remain as it is.

Before the calculated control output of the master controller is broadcasted to the slave controller(s), it is modulated in the event of the following conditions:

Master

- window open
- night purge
- air quality control (intake air only)
- Off from wall module
- frost protection
- space overheating

If any of these conditions will become true, the control output to be broadcasted is changed.

In the slave controller(s), the control output received from the master controller is also modulated but on the basis and in the event of different conditions. These can be any of the following:

Slave

- cascade control
- low and high limit control
- airflow contact
- drip-pan alarm
- condensation alarm
- dew point control
- fire

If any of these conditions will become true, the control output of the slave controller is changed.

NOTES: The modulation executed in an individual slave controller is done locally and independently of the master controller and other slave controllers.

The slave conditions are also evaluated in the master controller but will not be broadcasted to the slave controller(s).

IMPORTANT!

For any condition configured on the local slave controller, the corresponding sensor must be available and wired to the slave controller.

Communication and Value Aggregation

At places where Sylk wall modules are connected to controllers configured in a master/slave arrangement, the inputs from the wall modules connected to slave controllers can be aggregated by the master controller. The aggregated values are used by the master controller for the control sequences. The aggregated values are then shared with the wall modules connected to all controllers that are included in the master/slave arrangement.

NOTE: When using conventional wall modules with setpoint and/or fanspeed selection in a master-slave arrangement, only the master controller can have this type of wall module assigned. Hence, value aggregation is not applicable when using conventional wall modules of this type. In this case, conventional wall modules must be not used for slave controllers.

For CLCMTR40 Sylk wall modules, the following information can be aggregated by the master controller:

- Space Temperature [RmTemp]
- Manual Temperature Setpoint Selection [WMRmTempSp]
- Space CO2 [RmCO2]
- Space Relative Humidity [RmRH]
- Manual Occupancy Override (e.g. Bypass) Selection [WMOccOvrDsp]
- Manual Fan Speed Selection [WMFanManSwCmd]

- Manual HVAC mode Selection [WMHVACMd]

For CLCM TR42 Sylk wall modules, the following aggregated information can be displayed at each wall module:

- Space Temperature [WMRmTempDsp]
- Space Temperature Setpoint selection as relative or absolute value (not the effective setpoint) [WMRmTempSpDsp]
- Space CO2 [WMRmCO2Dsp]
- Space Relative Humidity [WMRmRHDsp]
- Manual Occupancy Override (e.g. Bypass) [WMFanManSwCmd]
- Manual Fan speed [WMFanManSwCmd]
- Manual HVAC mode [WMHVACMdDsp]
- Occupancy Mode [OccMd]

Communication

The communication between master controller and slave controller(s) can be unidirectional or bidirectional (see next table):

	Bidirectional	Unidirectional
Wallmodule and Sensors	S ↔ M	
Occupancy Mode		M → S
Space Temperature Setpoint		M → S
PID FCU Cascade Limit Control		M → S
Outputs		M → S

In bidirectional mode, values are sent and received from both, the master and the slave controller(s). The slave(s) send the values of the hardwired sensors to the master, the master makes aggregations and the effective sensor values are sent to the slave(s) again.

In unidirectional mode, values are sent only from the master to the slave controller(s).

The functions to be aggregated are set for the master and the master analyzes and applies the aggregation.

The configuration of the aggregation allows a flexible master-slave concept which minimizes bus traffic by disabling the communication for functions which are physically not installed. Any disabled function will not send messages to the master.

Value Aggregation

The master controller performs the values aggregation. The manner in which the master controller should aggregate the values received from the slave controller(s) can be configured for the various functions as follows:

- **Average**
takes the average value, e.g. space temperature and humidity
- **Local**
takes only the value of the wall module connected to the master
- **And/min**
applies an AND condition for digital contacts.
takes the min. value of analog values, e.g. uses the lowest space temperature from all wall modules as effective space temperature
- **Or/max**
applies an OR condition for digital contacts, e.g. window contact and occupancy sensor.
takes the max. value of analog values.
- **Last wins**
takes the last value, e.g. space temperature setpoint selection and wall module HVAC mode selection and fanspeed selection

Example:

Aggregation of Windows

There are 3 slaves each having a window contact configured. The windows are aggregated via OR function. If one of the slave sends a "window open", the master uses "window open" as result for the effective window position.

The following functions can be enabled/disabled and set for Sylk wall modules and sensors in a master-slave arrangement:

Wallmodule and Sensors	Default
Space Temperature [RmTemp]	Average
Space Temperature Setpoint selection* [WMRmTempSp]	Last wins
OnOff / Fanspeed Selection* [WMBypFanOvrd]	Last wins
WM HVAC Mode selection* [WMHVACMd]	Last wins
Humidity [RmRH]	Average
Air Quality [RmCO2]	Average
Occupancy Sensor [OccSens]	Or/Max
Door Contact [Door]	Or/Max
Card Reader [CardRd]	Or/Max
Window Contact [Window]	Or/Max

*only applicable to Sylk-WM.

NOTE: When using conventional wall modules, the master can have a wall module with max. functionality including space temperature sensor, setpoint selection, fanspeed switch, override button, humidity sensor, and air quality sensor. A wall module assigned to the slave controller(s) can have all functions except the setpoint selection and fanspeed switch. The sensor information provided by the wall module can be established via internal sensor or via external mounted sensors. The settings are to be done as follows:

Wallmodule and Sensors

Space Temp

Setpoint

On, Off / Fanspeed selection / Button *1

WM HVAC Mode

Occupancy Mode

Scheduler

WM Display of Override Mode

Eff Occupancy Mode

Space Temp Setpoint

WM Setpoint Mode Display (Sylk)

WM Low Lim Setpoint (Sylk)

WM Hi Lim Setpoint (Sylk)

Eff Setpoint Mode (Off, Cooling, Heating)

Eff Setpoint

*1 Only if the wallmodule has a Button only without a fanspeed switch.

Occupancy Mode	Default
Scheduler [OccSch]	enabled
WM Display of Override Mode (Handsymbol, Sylk) [WMBypDsp]	enabled*
Effective Occupancy Mode [OccMd]	enabled

*only necessary if Sylk-WM with display is installed at the slave

Space Temperature Setpoint	Default
WM Setpoint Mode Display (Sylk) [WMSpEffMd]	enabled*
WM Low Limit Setpoint Display (Sylk) [WMLoLimRmTempSpDsp]	enabled*
WM High Limit Setpoint Display (Sylk) [WMHiLimRmTempSpDsp]	enabled*
Effective Setpoint Mode [CtrlSpEffMd]	enabled

Space Temperature Setpoint	Default
Effective Setpoint [RmTempEffSp]	enabled

*only necessary if Sylk-WM with display is installed at the slave

PID FCU Cascade / Limit Control	Default
FCU Discharge Temperature Setpoint (prim to sec ctrl loop) [SaTempSp]	enabled

Outputs	Default
FCU Cooling [FCUClgMstrSlv]	enabled*
FCU DX-Cooling [FCUDxMstrSlv]	enabled*
FCU Heating [FCUhtgMstrSlv]	enabled*
FCU E-Heating [FCUEIhtgMstrSlv]	enabled*
FCU Fan [FCUFanSigMstrSlv]	enabled*
Ceiling Cooling [CeilClgMstrSlv]	enabled*
Ceiling Heating [CeilHtgMstrSlv]	enabled*
Radiator Heating [RadHtgMstrSlv]	enabled*
Underfloor Heating [UnFlrHtgMstrSlv]	enabled*
Fresh-Air Damper [IntakeDmprMstrSlv]	enabled*

*only necessary if installed at the slave

NOTE: The master controller must have configured all the functions of the slave controller.

Control Output Processing

The following schematic shows an example for the control output processing of a FCU cooling sequence in master-slave configuration.

The schematic is to be read from the right to the left.

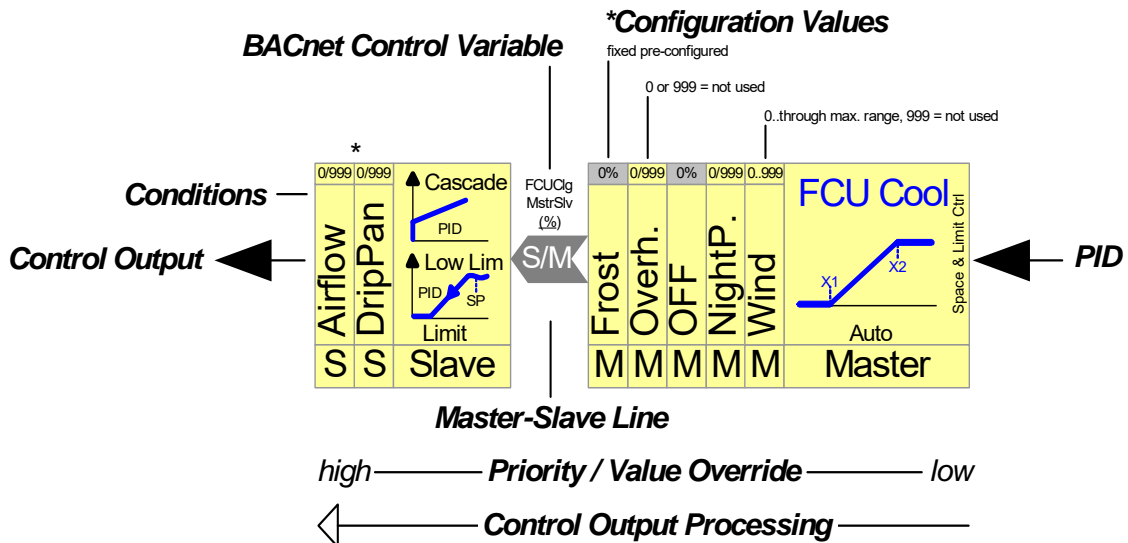

Master Strategy

The master on the right determines the control output based on the PID input value and the configurable X1 and X2 parameters.

The X1 and X2 parameters define the start and end level for the control sequence in %. When using the default values, 0 % for start level and 100 % for end level, multiple control sequences will work in parallel (e.g. FCU cooling and Ceiling cooling). The parameters can be used to shift parallel working sequences as follows:

Example:

First open the ceiling cooling valve and then open the FCU cooling valve by configuring X1 and X2 as follows:

Ceiling cooling: x1=0%, x2=50%
 FCU cooling: x1=50%, x2=100%.

NOTE: The parameters x1, x2 are used for normal heating and cooling control and for limit control but not for cascade control.

The calculated, unmodulated (see below) control output via PID input value and the configurable X1 and X2 parameters is the automatic control output (lowest priority) that is visible in RoomUp and on BACnet.

The calculated control output deliverable by the master is modulated before it is sent to the slave in the event of the following conditions:

- window open
- night purge activated
- Off from wall module
- space overheating
- frost protection

In the schematic, the conditions have ascending priority from right to the left and their values are set in one of the following ways:

- values in gray box (e.g. 0%) = fixed, not changeable by the user
- 0/999 = 0% or 999 (999 = ignore condition)
- 0..999 = 0% through max. % of range, (999=ignore condition)

When a condition becomes true, the control output is modulated according to the value configured for the true condition. The master processes all its conditions from right to left. Any true condition overrides the previous condition with lower priority and results in a new control output according to the value set for the true condition with the highest priority (i.e. Overheat has higher priority than Window). If none of the conditions are true, then the determined control output of the master will be sent to the slave unchanged.

After executing the last condition, in this case, Frost, the master sends its final control output via the BACnet control variable, in this case, FCUClgMsgtrSlv.

Slave Strategy

After receiving the control output from the master, the slave can apply the following control modes additionally and independently from the master:

- low limit control
- cascade control

Then the slave processes its own conditions independently from the master but according to the same rules (ascending priority and value override). The slave specific conditions are:

- drip-pan alarm
- airflow contact

After executing the last condition, in this case, Airflow, the slave sends its control output to the actuator.

Master-Slave Line - Self-acting Slave Device

The slave is a self-acting device that processes its individual conditions explicitly and modulates the control output independently from the control output delivered by the master. This is indicated in the schematic by the line between the master and the slave where the control output is transmitted via the BACnet control variable.

NOTES: The slave conditions, drip-pan and airflow, are also applicable to the master if configured, but vice versa, the conditions of the master are not applicable to the slave.

If the master has the drip-pan or airflow contact configured and the slave has not, the drip-pan information of the master to the slave will be ignored. This means that the slave must have its own drip-pan and airflow contact and in case of low limit and cascade control, it must have its own sensors.

Examples:

Control Output Processing in Master and Slave

- Master determines 30 % control output from PID and processes all conditions sequentially.
- Window is opened → condition "window" configured with 20 % is true
- All other conditions until and including "frost" are false
- Master sends 20 % via BACnet (FCUClgMsgtrSlv) to slave
- Slave receives 20 % and processes drip-pan and airflow conditions sequentially

- Drip-pan is full (alarm) → condition "drip-pan" configured with 0 % is true
- Slave determines the control output = 0% and closes the valve

NOTE: If the master has drip-pan alarm, it sends the determined control output = 20 % to the slave anyway.

Independent Low Limit Control and Cascade Control in Slave

If low limit temperature control is configured in the slave, the slave modulates the control output independently from the control output received from the master. This assures precise discharge temperature control also on the slave(s.)

FIRE MODE

The fire mode [PltFire] is initiated by the plant controller based on connections to smoke detectors and/or a contact from the fire alarm panel.

When fire mode is activated, the unit will be shut down and the fresh-air damper will be closed. The unit can be configured to run at a defined fan speed.

ALARMING

BACnet alarming can be applied in case of temperature undercut or exceedance measured by the appropriate sensors. For general information on BACnet alarming, please refer to the relevant BACnet literature by visiting any of the following sites:

www.bacnet.org
www.bacnetinternational.org
www.big-eu.org

General BACnet alarming is supported by the following sensors:

- Space temperature [RmTemp]
- Humidity [RmRH]
- Air quality [RmCO2]
- FCU discharge temperature [SaTemp]
- Ceiling cold water temperature [CeilWtrTemp]
- Underfloor temperature [UnFlrSupWtrTemp]
- Radiator radiation temperature [RadRadiTemp]
- Intake air temperature [IntakeDmprTemp]
- Cool/Heat Changeover Temperature [PltCngOvrWtrTemp]

In addition, these sensor provide a specific sensor failure function (see section "Sensor Failure Behavior ", p. 88)

The following sensors do not support BACnet alarming:

- Space temperature setpoint [WMRmTempSp]
- Fanspeed switch [WMFanManSwCmd]
- Airflow [AirFlow]
- Occupancy sensor [OccSens]
- Door contact [Door]
- Window contact [Window]
- Card reader [CardRd]
- Drip-pan [DripPan]
- Condensation [Cond]

For the following sensors and functions, the BACnet alarming properties can be enabled and defined:

- **Space temperature**
- **FCU discharge temperature**
- **Ceiling cold water**
- **Underfloor temperature**
- **Radiator radiation temperature**
- **Intake air**
- **Cool/Heat Changeover Temperature**

BACnet Property	Range / Selection	Default
Enable Alarm and Event Notification	Off, On	Off
Notify Type	Alarm, Event	Alarm
Notification Class	Urgent, High, Low	Urgent
To-Off Normal Transition	On, Off	On
To-Fault Normal Transition	On, Off	Off
Back to Normal Transition	On, Off	On
Enable High Limit	On, Off	On
High Limit	-5000..5000 °C	115 °C
Enable Low Limit	On, Off	On
Low Limit	-5000..5000 °C	-35 °C
Deadband (<high limit, >low limit)	0..5000	5

BACnet Property	Range / Selection	Default
Time delay (Stabilize time)	0..86400 sec	30 sec

Humidity

BACnet Property	Range / Selection	Default
Enable Alarm and Event Notification	Off, On	Off
Notify Type	Alarm, Event	Alarm
Notification Class	Urgent, High, Low	Urgent
To-Off Normal Transition	On, Off	On
To-Fault Normal Transition	On, Off	Off
Back to Normal Transition	On, Off	On
Enable High Limit	On, Off	On
High Limit	-5000..5000 °C	95
Enable Low Limit	On, Off	On
Low Limit	-5000..5000 °C	5.5
Deadband (<high limit, >low limit)	0..5000	2
Time Delay (Stabilize time)	0..86400 sec	30 sec

Air quality

BACnet Property	Range / Selection	Default
Enable Alarm and Event Notification	Off, On	Off
Notify Type	Alarm, Event	Alarm
Notification Class	Urgent, High, Low	Urgent
To-Off Normal Transition	On, Off	On
To-Fault Normal Transition	On, Off	Off
Back to Normal Transition	On, Off	On
Enable High Limit	On, Off	On
High Limit	0..5000 sec	1950 sec
Enable Low Limit	On, Off	On
Low Limit	0..5000 sec	100 sec
Deadband (<high limit, >low limit)	0..5000	50
Time Delay (Stabilize time)	0..86400 sec	30 sec

Sensor Failure Behavior

The following sensors support a specific sensor failure function.

Sensor	Failure Behavior
Air quality [RmCO2]	Sensor will be ignored and normal PID control is executed
Ceiling cold water temperature [CeilWtrTemp]	Condensation will be enabled
Cool/Heat Changeover Temperature [PltCngOvrWtrTemp]	Sensor will be ignored and [PltCngOvrMed] is evaluated
Fanspeed switch [WMFanManSwCmd]	Sensor will be ignored and fan is switched to Auto mode

Sensor	Failure Behavior
FCU discharge temperature [SaTemp]	Sensor will be ignored and normal PID control is executed
Humidity [RmRH]	Sensor will be ignored and the configured safety dewpoint [Parameter: Ceil_Dew_Point_Calc_Sp] is used
Intake air temperature [IntakeDmprTemp]	Damper will be closed to prevent cold air intake
Radiator radiation temperature [RadRadiTemp]	Sensor will be ignored and normal PID control is executed
Space temperature [RmTemp]	Changes to 0°C to support frost protection
Space temperature setpoint [WMRmTempSp]	Sensor will be ignored and 0 °C (relative) or 22 °C (absolute) setpoint is used
Underfloor temperature [UnFirSupWtrTemp]	Max.Temp Limitation will be enabled (0%)

ACCESS IRM CONTROLLER PARAMETERS

Parameters of IRM controllers can be accessed by using an EAGLE controller as MSTP router. The parameters will be accessed by loading a template parameter file (.CSV file) which is provided with the Centraline NX installation by default.

Load Parameters

Prerequisite Steps

1. Connect the IRM controller to the EAGLE controller via their MSTP interface. Please refer to the corresponding product data and mounting instructions.
2. In CARE, create the EAGLE controller and configure it as MSTP gateway.
3. Create a "dummy" plant including e.g. 1 analog value datapoint.
4. Download the application and the controller settings into the EAGLE controller (see CARE User Guide EN2Z-0937GE51).
5. Configure the IRM controller by using the RoomUp App (see IRM Application Guide EN2Z-1015GE51).

Procedure

1. In COACH NX / ARENA NX, discover the EAGLE and IRM controllers.

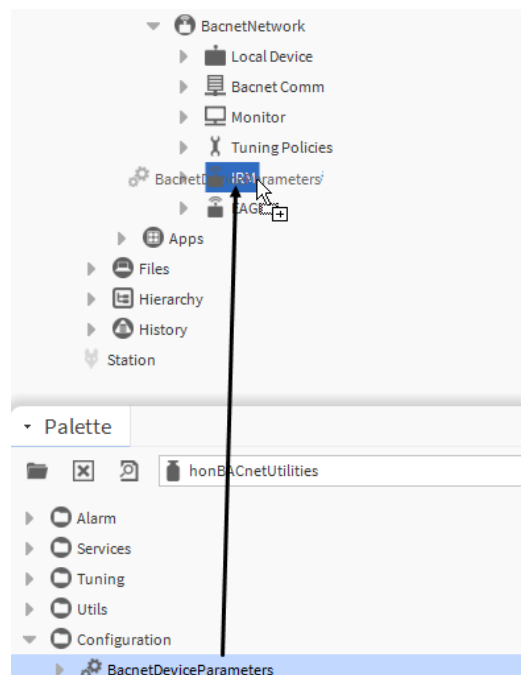

2. In the *Palette* tab at the bottom, select **honBACnetUtilities** from the drop-down listbox, then open *Configuration*, and then drag&drop the parameters item, in this case, **BACnetDeviceParameters** to the IRM controller.

NOTE: Multiple parameter items can be added to the IRM controller.

RESULT: The *Name* dialog box is displayed.

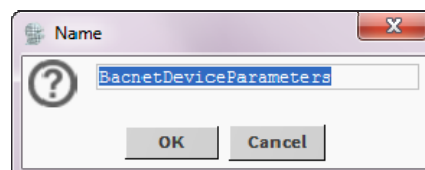

3. Change the name if desired, and then click **OK**.

RESULT: The parameters item is added to the controller as indicated in the tree.

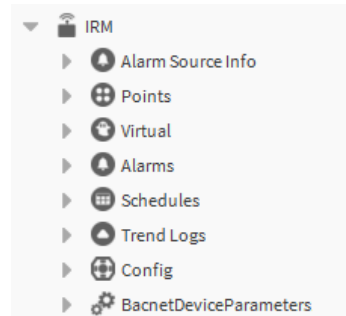

4. Double-click on the parameters item.

RESULT: On the Property Sheet on the right, the CSV file can be selected from the **Parameter Set** drop-down listbox.

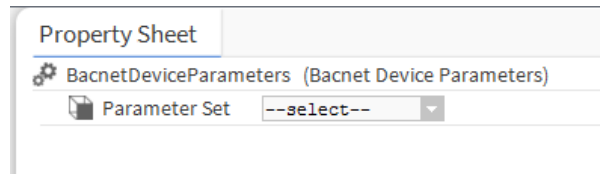

NOTE: Parameter sets are listed according to the Vendor ID and the Model Name of the BACnet device. One parameter set can fit to multiple model names. Only matching parameter sets will be selectable. If no matching parameter set is found, a message is displayed.

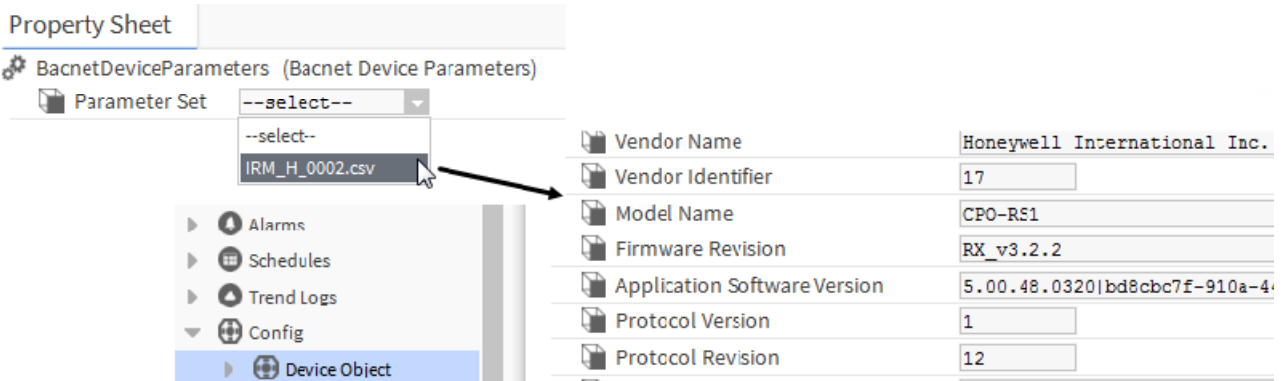

The action **Load Set List** will refresh the list of available parameter sets.

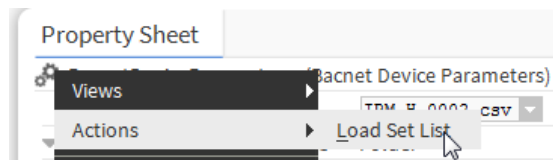

5. Select the CSV file, in this case, IRM H_0002.csv.

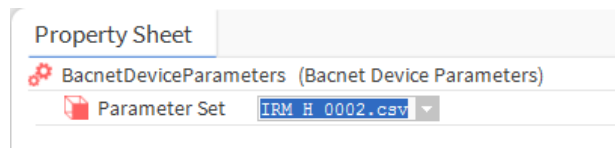

RESULT: The parameters are displayed according to the IRM RoomUp structure. The parameters can be further grouped in subfolders

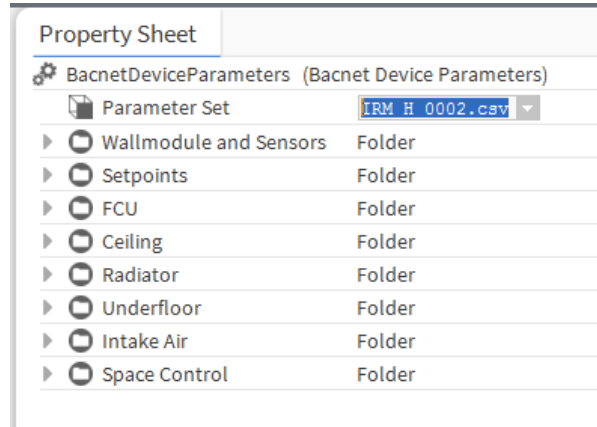

Change Parameters

The parameters have value and status, and they are only polled when visible. Values can be changed directly in the field or by using the **Set** action. Based on the Facet setting = default, the default value can be written using the **Set Default** action.

The status changes when read or write faults occur.

- Procedure**
1. To edit parameters, expand the corresponding tree item.

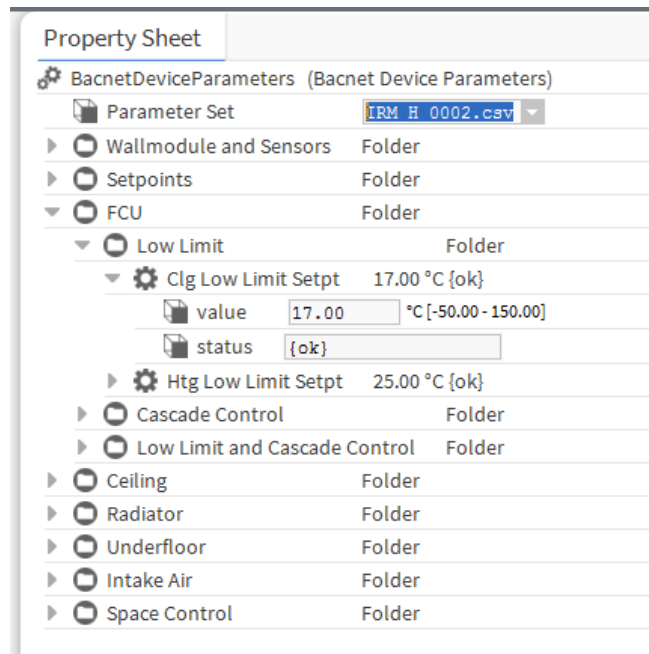

2. Change the value directly in the field, and then click the **Save** button at the bottom.

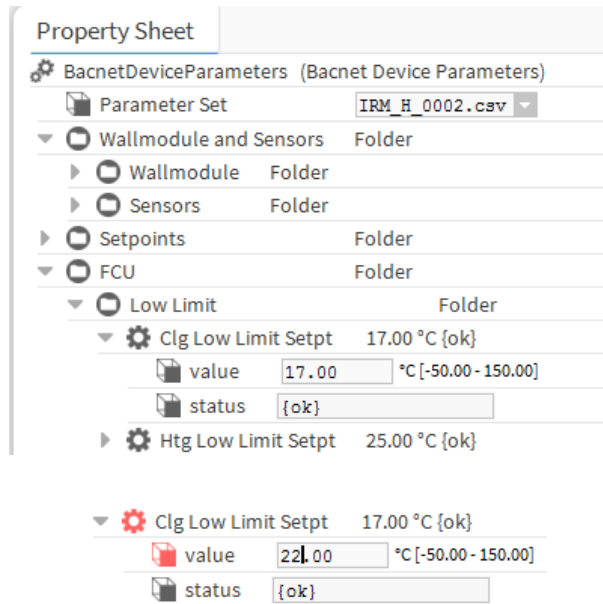

RESULT: The value is updated.

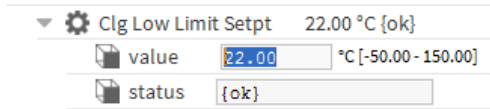

3. Alternatively, you can change parameters by using the **Set** action.

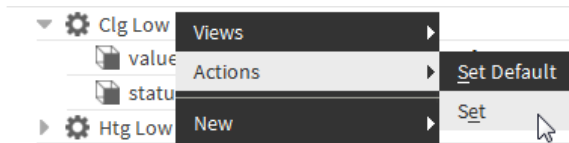

4. To do so, right-click on the parameter setting which is indicated by the icon , select **Actions**, and then click **Set** in the context menu.

RESULT: The *Set* dialog box is displayed.

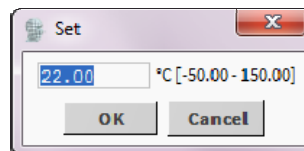

5. Change the value, and then click **OK**.

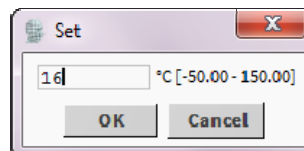

RESULT: The value is updated.

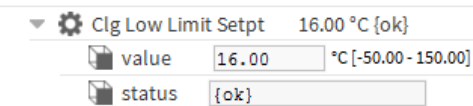

Binding of Parameters

Parameters can be bound using standard Niagara Widget functions such as:

- Label binding
- PX file usage
- Palette items bindings (animated graphics, boolean types, etc.)
- Field editor usage
- Actions binding

Please refer to the basic Niagara documentation for detailed information on these techniques.

Updating Parameters

Parameters will be updated by loading a new .CSV file.

Prerequisites In COACH NX, a station must be created containing a BACnet MS/TP network with a MERLIN controller.

- Procedure**
1. On the PC, copy the template parameter file (e.g. *IRM_H_0005.csv*) to a folder of your choice.
 2. In COACH NX, copy the .CSV file from that folder to the station.

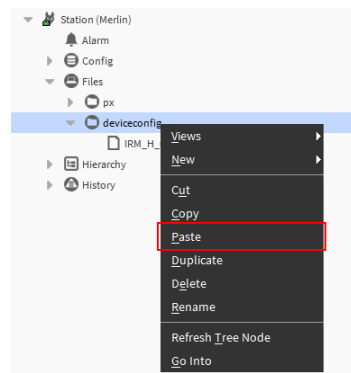
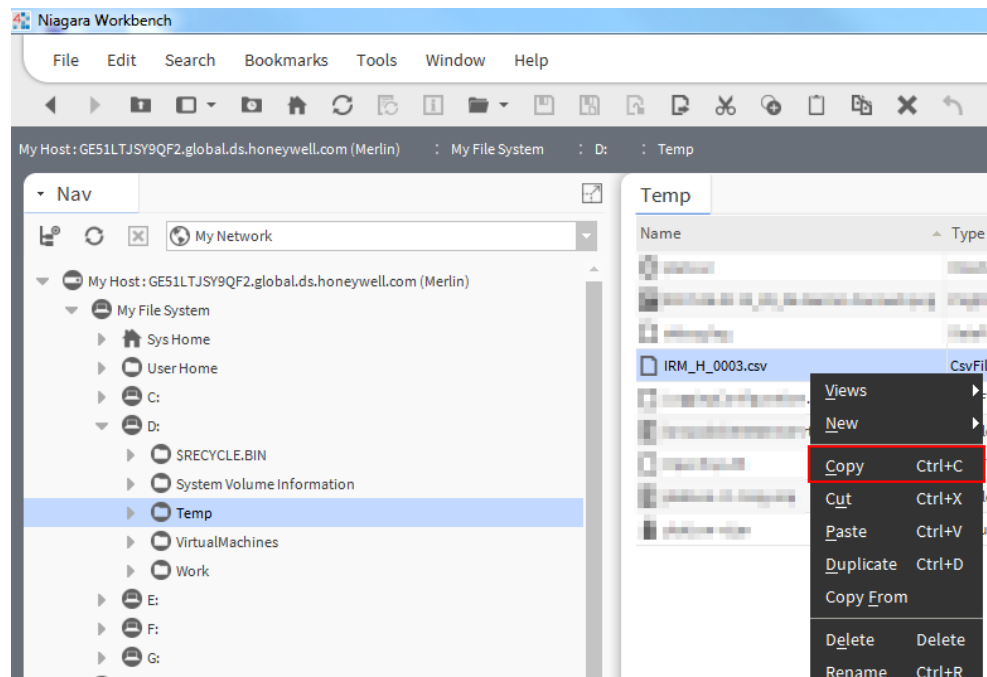

NOTE: The *deviceconfig* folder will be created after a **BACetDeviceParameters** component is dragged onto an IRM controller the first time. Next time a **BacnetDeviceParameters** component is used, it will provide the newly added template.

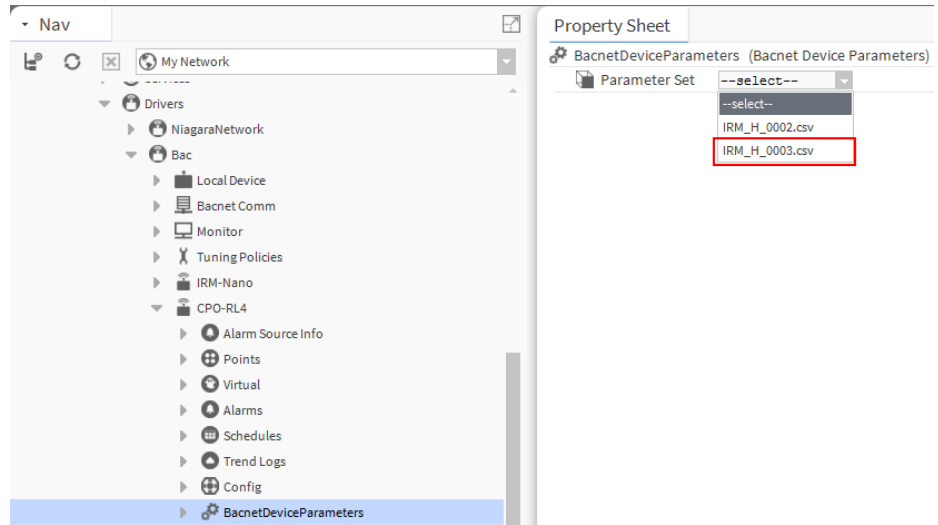

3. For *BacnetDeviceParameters* components already available, reload the list of templates in order to show the added template in the list box.

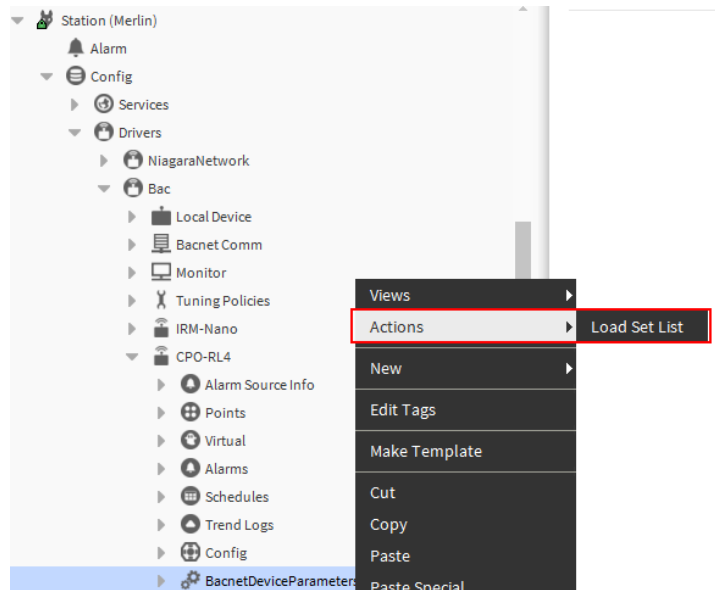

APPENDIX

BACnet Variables Overview

Table 11. BACnet objects sent from the plant controller to the room controller

Object	Object Name	Short Description	Range, Units, State Text	R/W	Safety/Default Value	BACnet Visibility Rule
AO	FreeAO01	Free Analog Output 01	0..100%	W	0%	Terminal cfg
AO	FreeAO02	Free Analog Output 02	0..100%	W	0%	Terminal cfg
AO	FreeAO03	Free Analog Output 03	0..100%	W	0%	Terminal cfg
AO	FreeAO04	Free Analog Output 04	0..100%	W	0%	Terminal cfg
BO	FreeBO01	Free Binary Output 01	0=Off, 1=On	W	0=Off	Terminal cfg
BO	FreeBO02	Free Binary Output 02	0=Off, 1=On	W	0=Off	Terminal cfg
BO	FreeBO03	Free Binary Output 03	0=Off, 1=On	W	0=Off	Terminal cfg
BO	FreeBO04	Free Binary Output 04	0=Off, 1=On	W	0=Off	Terminal cfg
AV	OaExtComp	Outside Air Temp External Comp	-10..10delta°C	W	0 delta °C	Always exposed
AV	OaTemp	Outside Air Temp	-100..150°C	W	0°C	Always exposed
MV	OccSch	Plant Occupancy Schedule	1=Unocc, 2=Stby, 3=Occ	W	3=Occ	Always exposed
MV	PltCngOvrMed	Plant Change Over Medium	1=Off, 2=Clg, 3=Htg	W	1=Off	Always exposed
BV	PltFire	Plant Fire	0=No fire, 1=Fire	W	0=No fire	Always exposed
MV	PltHVACMd	Plant HVAC Mode	1=Off, 2=Clg, 3=Htg, 4=Auto	W	4=Auto	Always exposed
BV	PltNiPrgEn	Plant Night Purge Enable	0=Disable, 1=Enabled Night Purge	W	0=Disable	Always exposed
MV	WMExtRst	WM External Reset	1=NoReset, 2=SP, 3=Fan, 4=Override, 5=HVAC, 6=ALL	W	1=NoReset	Always exposed

Table 12. BACnet objects sent from the room controller to the plant controller

Object	Object Name	Short Description	Range, Units, State Text	R/W	Safety/Default Value	BACnet Visibility Rule
AO	Ceil6WayVlvCtl	Ceil 6 Way Valve Control	0..100%	R	0%	Ceiling 6-way valve
AO	CeilClgCtl	Ceil Clg Output	0..100%	R	0%	Ceiling Clg
AO	CeilCngOvrVlvCtl	Ceil Change Over Valve Output	0..100%	R	0%	Ceiling 2-pipe
AO	CeilHtgCtl	Ceil Htg Output	0..100%	R	0%	Ceiling Htg
AV	DewPntTemp	Ceil Dewpoint calculated	-50..150°C	R	0	Ceiling Clg Dewpoint
AO	Fcu6WayVlvCtl	FCU 6 Way Valve Control	0..100%	R	0%	FCU 6-way valve
AO	FCUClgCtl	FCU Clg Output	0..100%	R	0%	FCU Clg
AO	FCUCngOvrVlvCtl	FCU Change Over Valve Output	0..100%	R	0%	FCU 2-pipe
BO	FCUDxClgBO1	FCU DX-Clg BO1	0=Off, 1=On	R	0=Off	FCU DX-Clg
BO	FCUDxClgBO2	FCU DX-Clg BO2	0=Off, 1=On	R	0=Off	FCU DX-Clg
AO	FCUDxClgCtl	FCU DX-Clg Output	0..100%	R	0%	FCU DX-Clg
BO	FCUEIHtgBO1	FCU E-Htg BO1	0=Off, 1=On	R	0=Off	FCU E-Htg

Object	Object Name	Short Description	Range, Units, State Text	R/W	Safety/Default Value	BACnet Visibility Rule
BO	FCUEIHtgBO2	FCU E-Htg BO2	0=Off, 1=On	R	0=Off	FCU E-Htg
AO	FCUEIHtgCtl	FCU E-Htg Output	0..100%	R	0%	FCU E-Htg
AO	FCUHtgCtl	FCU Htg Output	0..100%	R	0%	FCU Htg
ACC	FreeACC01	Free Accumulator 01	no-units	R	0	Terminal cfg
ACC	FreeACC02	Free Accumulator 02	no-units	R	0	Terminal cfg
AI	FreeAI01.PresentValue	Free Analog Input 01	no-units	R	0	Terminal cfg
AI	FreeAI02.PresentValue	Free Analog Input 02	no-units	R	0	Terminal cfg
AI	FreeAI03.PresentValue	Free Analog Input 03	no-units	R	0	Terminal cfg
AI	FreeAI04.PresentValue	Free Analog Input 04	no-units	R	0	Terminal cfg
AI	FreeAI05.PresentValue	Free Analog Input 05	no-units	R	0	Terminal cfg
BI	FreeBI01	Free Binary Input 01	0=Off, 1=On	R	0=Off	Terminal cfg
BI	FreeBI02	Free Binary Input 02	0=Off, 1=On	R	0=Off	Terminal cfg
BI	FreeBI03	Free Binary Input 03	0=Off, 1=On	R	0=Off	Terminal cfg
BI	FreeBI04	Free Binary Input 04	0=Off, 1=On	R	0=Off	Terminal cfg
BI	FreeBI05	Free Binary Input 05	0=Off, 1=On	R	0=Off	Terminal cfg
AO	IntakeDmprCtl	Intake Air Dampr Output	0..100%	R	0%	Intake Air
BV	OccSensCardRdEff	Effective Occupancy Sensor	0=Unocc, 1=Occ	R	0=Unocc	Always exposed
AO	RadHtgCtl	Radiator Htg Output	0..100%	R	0%	Radiator Htg
AO	UnFlrHtgCtl	Underfloor Htg Output	0..100%	R	0%	Underfloor Htg

Table 13. BACnet objects from external wallmodule or controller

Object	Object Name	Short Description	Range, Units, State Text	R/W	Safety/Default Value	BACnet Visibility Rule
MV	ExtFanManSwCmd	WM On/Off/Fanspeed Cmd	1=Off, 2=Auto, 3=Low/On, 4=Medium, 5=High, 6=No Override	W	2=Auto	Always exposed
MV	ExtHVACMd	External HVAC Mode	1=Off, 2=Clg, 3=Htg, 4=Auto, 5=No override	W	5=No override	Always exposed
MV	ExtOccMd	External Occupancy mode	1=Unocc, 2=Stby, 3=Occ, 4=OccOvr, 5=Holiday, 6=No override	W	6=No override	Always exposed
MV	ExtOccSens	External Occupancy Sensor	1=Unused, 2=Unocc, 3=Occ, 4=OccOvr	W	1=Unused	Always exposed
AV	ExtRmCO2	External Room Carbon Dioxide	0..3000ppm, 0..100%	W	0ppm/%	Always exposed
AV	ExtRmRH	External Room Relative Humidity	0..100%	W	999%	Always exposed
AV	ExtRmTemp	External Room Temperature	-50..150°C	W	999°C	Always exposed
AV	ExtRmTempSp	External Room Temperature Setpoint rel/abs	-50..150°C	W	999°C	Always exposed
MV	ExtWindow	External Window Contact	1=Unused, 2=W closed, 3=W open	W	1=Unused	Always exposed

NOTE: In case these BACnet objects are used, then it is not required to configure that sensor(s) via RoomUp. It is enough to write to these BACnet objects. If a hardwired and a BACnet sensor is used, then the BACnet sensor has priority (except for the occupancy sensor and the window contact, please refer to the chapter "Sensors").

Table 14. BACnet objects for monitoring

Object	Object Name	Short Description	Range, Units, State Text	R/W	Safety/Default Value	BACnet Visibility Rule
BI	AirFlow	Air Flow Contact	0=NoFlow;1=Flow	R	1=Flow	Terminal cfg
AV	BypRemTim	Remaining Bypass Time	0..1080min	R	0min	Always exposed
BI	CardRd	Card Reader Contact	0=Unocc; 1=Occ	R	0=Unocc	Terminal cfg, M/S
PAR	Ceil_Clg_Dsp_Prty	Ceil Clg Output cause	0..33, see "Output cause"	R	0=Wait for DDC	Ceiling Clg
PAR	Ceil_Htg_Dsp_Prty	Ceil Htg Output cause	0..33, see "Output cause"	R	0=Wait for DDC	Ceiling Htg
AO	Ceil6WayVlvCtl	Ceil 6 Way Valve Control	0..100%	R	0%	Ceiling 6-way valve
AO	CeilClgCtl	Ceil Clg Output	0..100%	R	0%	Ceiling Clg
AO	CeilCngOvrVlvCtl	Ceil Change Over Valve Output	0..100%	R	0%	Ceiling 2-pipe
AO	CeilHtgCtl	Ceil Htg Output	0..100%	R	0%	Ceiling Htg
BO	CeilSwOvrClgVlvCmd	Ceil Switch Over Vlv Cmd Clg	0=Off, 1=On	R	0=Off	Ceiling Switch-Over 2-way
BO	CeilSwOvrHtgVlvCmd	Ceil Switch Over Vlv Cmd Htg	0=Off, 1=On	R	0=Off	Ceiling Switch-Over 2-way
BO	CeilSwOvrVlvCmd	Ceil Switch Over Vlv Cmd 3-way	0=Off, 1=On	R	0=Off	Ceiling Switch-Over 3-way
AI	CeilWtrTemp.PresentValue	Ceil Clg Water Temperature	-50..150°C	R	999°C	Terminal cfg
BI	Cond	Condensation Contact	0=Dry; 1=Condensation	R	0=Dry	Terminal cfg
MV	CtrlMd	Effective HVAC mode	1=Off, 2=Clg, 3=Htg, 4=Auto	R	4=Auto	Always exposed
MV	CtrlSpEffMd	Effective Space Setpt mode	1=Off, 2=Clg, 3=Htg	R	3=Htg	Always exposed
AV	DewPntTemp	Ceil Dewpoint calculated	-50..150°C	R	0	Ceiling Clg Dewpoint
PAR	Dm_Dsp_Prty	Intake Air Dampr Output cause	0..33, see "Output cause"	R	0=Wait for DDC	Intake Air
BI	Door	Door Contact	0=Close; 1=Open	R	0=Close	Terminal cfg, M/S
BI	DripPan	Drip Pan Contact	0=Normal; 1=Alarm	R	0=Normal	Terminal cfg
MV	ExtFanManSwCmd	WM On/Off/Fanspeed Cmd	1=Off, 2=Auto, 3=Low/On, 4=Medium, 5=High	R	2=Auto	Always exposed
MV	ExtHVACMd	External HVAC mode	1=Off, 2=Clg, 3=Htg, 4=Auto, 5=No override	R	5=No override	Always exposed
MV	ExtOccMd	External Occupancy mode	1=Unocc, 2=Stby, 3=Occ, 4=Byp, 5=Holiday, 6=No ovrd	W	6=No override	Always exposed
MV	ExtOccSens	External Occupancy Sensor	1=Unused, 2=Unocc, 3=Occ, 4=OccOvr	W	1=Unused	Always exposed
AV	ExtRmCO2	External Room Carbon Dioxide	0..3000ppm, 0..100%	R	0ppm/%	Always exposed
AV	ExtRmRH	External Room Relative Humidity	0..100%	R	50%	Always exposed
AV	ExtRmTemp	External Room Temperature	-50..150°C	R	22°C	Always exposed
AV	ExtRmTempSp	External Room Temperature	-50..150°C	R	22°C	Always exposed

Object	Object Name	Short Description	Range, Units, State Text	R/W	Safety/ Default Value	BACnet Visibility Rule
		Setpoint				
MV	ExtWindow	External Window Contact	1=Unused, 2=W closed, 3=W open	W	1=Unused	Always exposed
BO	FaDmprCmd	Intake Air Dampr Command	0=Off, 1=On	R	0=Off	Intake Air
PAR	Fan_Dsp_Prty	FCU Fan Output cause	0..33, see "Output cause"	R	0=Wait for DDC	FCU Fan
AO	FanSpdCtl	FCU Fan Variable Speed Output	0..100%	R	0%	FCU Fan Variable
PAR	FCU_Clg_Dsp_Prty	FCU Clg Output cause	0..33, see "Output cause"	R	0=Wait for DDC	FCU Clg
PAR	FCU_DX-C_Dsp_Prty	FCU DX-Clg Output cause	0..33, see "Output cause"	R	0=Wait for DDC	FCU DX-Clg
PAR	FCU_EI-H_Dsp_Prty	FCU E-Htg Output cause	0..33, see "Output cause"	R	0=Wait for DDC	FCU E-Htg
PAR	FCU_Htg_Dsp_Prty	FCU Htg Output cause	0..33, see "Output cause"	R	0=Wait for DDC	FCU Htg
AO	Fcu6WayVlvCtl	FCU 6 Way Valve Control	0..100%	R	0%	FCU 6-way valve
AO	FCUClgCtl	FCU Clg Output	0..100%	R	0%	FCU Clg
AO	FCUCngOvrVlvCtl	FCU Change Over Valve Output	0..100%	R	0%	FCU 2-pipe
BO	FCUDxClgBO1	FCU DX-Clg BO1	0=Off, 1=On	R	0=Off	FCU DX-Clg
BO	FCUDxClgBO2	FCU DX-Clg BO2	0=Off, 1=On	R	0=Off	FCU DX-Clg
AO	FCUDxClgCtl	FCU DX-Clg Output	0..100%	R	0%	FCU DX-Clg
BO	FCUEIHtgBO1	FCU E-Htg BO1	0=Off, 1=On	R	0=Off	FCU E-Htg
BO	FCUEIHtgBO2	FCU E-Htg BO2	0=Off, 1=On	R	0=Off	FCU E-Htg
AO	FCUEIHtgCtl	FCU E-Htg Output	0..100%	R	0%	FCU E-Htg
MV	FCUFanStgCmd	FCU Fan Effective Fanstage	1=Off, 2=Spd1, 3=Spd2, 4=Spd3	R	1=Off	FCU Fan Staged
AO	FCUHtgCtl	FCU Htg Output	0..100%	R	0%	FCU Htg
ACC	FreeACC01	Free Accumulator 01	no-units	R	0	Terminal cfg
ACC	FreeACC02	Free Accumulator 02	no-units	R	0	Terminal cfg
AI	FreeAI01.PresentValue	Free Analog Input 01	no-units	R	0	Terminal cfg
AI	FreeAI02.PresentValue	Free Analog Input 02	no-units	R	0	Terminal cfg
AI	FreeAI03.PresentValue	Free Analog Input 03	no-units	R	0	Terminal cfg
AI	FreeAI04.PresentValue	Free Analog Input 04	no-units	R	0	Terminal cfg
AI	FreeAI05.PresentValue	Free Analog Input 05	no-units	R	0	Terminal cfg
BI	FreeBI01	Free Binary Input 01	0=Off, 1=On	R	0=Off	Terminal cfg
BI	FreeBI02	Free Binary Input 02	0=Off, 1=On	R	0=Off	Terminal cfg
BI	FreeBI03	Free Binary Input 03	0=Off, 1=On	R	0=Off	Terminal cfg
BI	FreeBI04	Free Binary Input 04	0=Off, 1=On	R	0=Off	Terminal cfg

Object	Object Name	Short Description	Range, Units, State Text	R/W	Safety/ Default Value	BACnet Visibility Rule
BI	FreeBI05	Free Binary Input 05	0=Off, 1=On	R	0=Off	Terminal cfg
AO	IntakeDmprCtl	Intake Air Dmpr Output	0..100%	R	0%	Intake Air
AI	IntakeDmprTemp.PresentValue	Intake Air Dmpr Clg Intake Temperature	-50..150°C	R	999°C	Terminal cfg
AV	OaExtComp	Outside Air Temp External Comp	-10..10delta°C	W	0 delta °C	Always exposed
AV	OaTemp	Outside Air Temp	-100..150°C	W	0°C	Always exposed
MV	OccMd	Effective Occupancy Mode	1=Unocc, 2=Stby, 3=Occ, 4=By, 5=Holiday	R	3=Occ	Always exposed
MV	OccSch	Plant Occupancy Schedule	1=Unocc, 2=Stby, 3=Occ	W	3=Occ	Always exposed
BI	OccSens	Occupancy Sensor Contact	0=UnOcc; 1=Occ	R	UnOccupied	Terminal cfg, M/S
BV	OccSensCardRdEff	Effective Occupancy Sensor	0=Unocc, 1=Icc	R	0=Unocc	Always exposed
MV	PltCngOvrMed	Plant Change Over Medium	1=Off, 2=Clg, 3=Htg	W	1=Off	Always exposed
AI	PltCngOvrWtrTemp.PresentValue	Cool/Heat changeover sensor	-50..150°C	R	999°C	Terminal cfg
BV	PltFire	Plant Fire	0=No fire, 1=Fire	W	0=No fire	Always exposed
MV	PltHVACMd	Plant HVAC Mode	1=Off, 2=Clg, 3=Htg, 4=Auto	W	4=Auto	Always exposed
BV	PltNiPrgEn	Plant Night Purge Enable	0=Disable, 1=Enabled Night Purge	W	0=Disable	Always exposed
PAR	Rad_Htg_Dsp_Prty	Radiator Htg Output cause	0..33, see "Output cause"	R	0=Wait for DDC	Radiator Htg
AO	RadHtgCtl	Radiator Htg Output	0..100%	R	0%	Radiator Htg
AI	RadRadiTemp.PresentValue	Radiator Htg Radiation Temperature	-50..150°C	R	999°C	Terminal cfg
AI	RmCO2.PresentValue	WM CO2 Measurement	0..3000ppm, 0..100%	R	0ppm/%	Terminal cfg, M/S
AI	RmRH.PresentValue	Relative Humidity	0..100%	R	999%	Terminal cfg, M/S
AI	RmTemp.PresentValue	Space Temperature	-50..150°C	R	20°C	Terminal cfg, M/S
AV	RmTempEffSp	Effective Room Temp Setpt	-50..150°C	R	21°C	Always exposed
AI	SaTemp.PresentValue	Discharge Temperature	-50..150°C	R	999°C	Terminal cfg
PAR	UnFir_Htg_Dsp_Prty	Underfloor Htg Output cause	0..33, see "Output cause"	R	0=Wait for DDC	Underfloor Htg
AO	UnFirHtgCtl	Underfloor Htg Output	0..100%	R	0%	Underfloor Htg
AI	UnFirSupWtrTemp.PresentValue	Underfloor Htg Supply Water Temperature	-50..150°C	R	0°C	Terminal cfg
BI	Window	Window Contact	0=Close; 1=Open	R	0=Close	Terminal cfg, M/S
AI	WMBypFanOvrD.PresentValue	WW Fan OvrD + Bypass Selection	0=By, 1=Spd1, 2=Spd2, 3=Spd3, 4=Off/Normal, 5	R	5=Auto	Terminal cfg, M/S

Object	Object Name	Short Description	Range, Units, State Text	R/W	Safety/ Default Value	BACnet Visibility Rule
AI	WMRmTempSp.PresentValue	WM Space Temp Setpt Selected	-5..5delta°C, 12..30°C, 0..100%	R	20°C	Terminal cfg, M/S

NOTE: PAR objects in this table are only available in RoomUp Monitor

Table 15. BACnet objects as parameter list

Object	Object Name	Short Description	Range, Units, State Text	R/W	Safety/ Default Value	BACnet Visibility Rule
BV	ApplicationUnit.RelDefault	Engineering Unit for Temperature	0=SI, 1=IP	R/W*3	0=SI	Always exposed
PAR	Cas_Rm_Ctrl_TiClg	FCU Cascade lead ctrl Clg, Reset Time	0..3600sec	R/W*1	1200sec	FCU Clg Cascade lead
PAR	Cas_Rm_Ctrl_TiHtg	FCU Cascade lead ctrl Htg, Reset-Time	0..3600sec	R/W*1	1200sec	FCU Htg Cas lead
PAR	Cas_Rm_Ctrl_XpClg	FCU Cascade lead ctrl Clg, XP-Band	0..1000delta°C	R/W*1	20delta°C	FCU Clg Cascade lead
PAR	Cas_Rm_Ctrl_XpHtg	FCU Cascade lead ctrl Htg, XP-Band	0..1000delta°C	R/W*1	20delta°C	FCU Htg Cas lead
PAR	Ceil_Clg_Cond_Prot_Xp	Ceil Dewpoint Protection, XP-Band	0..1000delta°C	R/W*1	2delta°C	Ceiling Clg
PAR	Ceil_Dew_Point_Calc_Sp	Ceil Dewpoint if not calculated	0..150°C	R/W*1	35°C	Ceiling Clg Dewpoint
AI	CeilWtrTemp.SensorOffset	Ceil Clg Water Temperature	-5..5°C	R/W*3	0°C	Terminal cfg
PAR	Clg_DisSp_Stop_Value	FCU Cascade Clg Stop Level from leading Ctrl	0..100 %	R/W*1	100%	FCU Cas lead
PAR	Clg_Fan_Start_Value	FCU Cascade Fan Start Level Clg from leading Ctrl	0..100 %	R/W*1	30%	FCU Cas lead
PAR	Dm_Air_Qty_Ctrl_Xp	Intake Air Dampr Air Quality Ctrl, XP-Band	0..1000ppm, %	R/W*1	100ppm, %	Intake Air Quality
PAR	Dm_Lo_Lim_Ctrl_Xp	Intake Air Dampr Clg Low Limit, XP-Band	-50..150°C	R/W*1	1.5delta°C	Intake Air Clg
PAR	FCU_Clg_Lim_Ctrl_Ti	FCU Clg Low Limit or Cas Ctrl, Reset Time	0..3600sec	R/W*1	300sec	FCU Clg Cas follow, Limit
PAR	FCU_Clg_Lim_Ctrl_Xp	FCU Clg Low Limit or Cas Ctrl, XP-Band	0..1000delta°C	R/W*1	8delta°C	FCU Clg Casc follow, Limit
PAR	FCU_DX-C_Lim_Ctrl_Ti	FCU DX-Clg Low Limit or Cas Ctrl, Reset Time	0..3600sec	R/W*1	300sec	FCU DX-Clg Cas follow, Limit
PAR	FCU_DX-C_Lim_Ctrl_Xp	FCU DX-Clg Low Limit or Cas Ctrl, XP-Band	0..1000delta°C	R/W*1	8delta°C	FCU DX-Clg Cas follow, Limit
PAR	FCU_EI-H_Lim_Ctrl_Ti	FCU E-Htg Low Limit or Cas Ctrl, Reset Time	0..3600sec	R/W*1	300sec	FCU E-Htg Cas follow, Limit
PAR	FCU_EI-H_Lim_Ctrl_Xp	FCU E-Htg Low Limit or Cas Ctrl, XP-Band	0..1000delta°C	R/W*1	8delta°C	FCU E-Htg Cas follow, Limit
PAR	FCU_Htg_Lim_Ctrl_Ti	FCU Htg Low Limit or Cas Ctrl, Reset Time	0..3600sec	R/W*1	300sec	FCU Htg Cas follow, Limit
PAR	FCU_Htg_Lim_Ctrl_Xp	FCU Htg Low Limit	0..1000delta°C	R/W*1	8delta°C	FCU Htg Cas

Object	Object Name	Short Description	Range, Units, State Text	R/W	Safety/Default Value	BACnet Visibility Rule
		or Cas Ctrl, XP-Band				follow, Limit
AV	FCUSaClgLoLimSp.RelDefault	FCU Clg Low Limit Setpt	-50..150°C	R/W*3	17°C	FCU Clg Limit
AV	FCUSaHtgLoLimSp.RelDefault	FCU Htg Low Limit Setpt	-50..150°C	R/W*3	25°C	FCU Htg Limit
AI	FreeAI01.SensorOffset	Free Analog Input 01	no-units	R/W*3	0	Terminal cfg
AI	FreeAI02.SensorOffset	Free Analog Input 02	no-units	R/W*3	0	Terminal cfg
AI	FreeAI03.SensorOffset	Free Analog Input 03	no-units	R/W*3	0	Terminal cfg
AI	FreeAI04.SensorOffset	Free Analog Input 04	no-units	R/W*3	0	Terminal cfg
AI	FreeAI05.SensorOffset	Free Analog Input 05	no-units	R/W*3	0	Terminal cfg
PAR	Htg_DisSp_Stop_Value	FCU Cascade Htg Stop Level from leading Ctrl	0..100 %	R/W*1	100%	FCU Cas lead
PAR	Htg_Fan_Start_Value	FCU Cascade Fan Start Level Htg from leading Ctrl	0..100 %	R/W*1	30%	FCU Cas lead
AV	IntakeDmprOccLoTempSp.RelDefault	Intake Air Dmpr Clg Low Lim Setpt Occ, Byp	-50..150°C	R/W*3	20°C	Intake Air Clg
AI	IntakeDmprTemp.SensorOffset	Intake Air Dmpr Clg Intake Temperature	-5..5°C	R/W*3	0°C	Terminal cfg
AV	IntakeDmprUnOccLoTempSp.RelDefault	Intake Air Dmpr Clg Low LimSetpt Hol, Unocc, Stby	-50..150°C	R/W*3	18°C	Intake Air Clg
AV	OccClgSp.RelDefault	Setpt Temp Clg Occ	-50..150 °C	R/W*3	23°C	Space Temp Clg
AV	OccHtgSp.RelDefault	Setpt Temp Htg Occ	-50..150 °C	R/W*3	21°C	Space Temp Htg
AI	PltCngOvrWtrTemp.SensorOffset	Cool/Heat changeover sensor	-5..5°C	R/W*3	0°C	Terminal cfg
PAR	Rad_Lo_Lim_Ctrl_Sp	Radiator Htg Low Limit Setpt	-50..150°C	R/W*1	25°C	Radiator Htg Limit
PAR	Rad_Lo_Lim_Ctrl_Xp	Radiator Htg Low Limit XP-Band	0..1000delta°C	R/W*1	1.5delta°C	Radiator Htg Limit
AI	RadRadiTemp.SensorOffset	Radiator Htg Radiation Temperature	-5..5°C	R/W*3	0°C	Terminal cfg
PAR	Rm_Ctrl_TdClg	Space Ctrl PID Clg, Derivative Time	0..3600sec	R/W*1	0sec	Space temp Clg
PAR	Rm_Ctrl_TdHtg	Space Ctrl PID Htg, Derivative Time	0..3600sec	R/W*1	0sec	Space temp Htg
PAR	Rm_Ctrl_TiClg	Space Ctrl PID Clg Ctrl, Reset Time	0..3600sec	R/W*1	300sec	Space temp Clg
PAR	Rm_Ctrl_TiHtg	Space Ctrl PID Htg Ctrl, Reset Time	0..3600sec	R/W*1	300sec	Space temp Htg
PAR	Rm_Ctrl_XpClg	Space Ctrl PID Clg Ctrl, XP-Band	0..1000delta°C	R/W*1	3.0delta°C	Space temp Clg
PAR	Rm_Ctrl_XpHtg	Space Ctrl PID Htg Ctrl, XP-Band	0..1000delta°C	R/W*1	3.0delta°C	Space temp Htg
AI	RmCO2.SensorOffset	WM CO2 Measurement	-500..500ppm, -10..10%	R/W*3	0ppm/0%	Terminal cfg, M/S
AV	RmFrostSp.RelDefault	Temp Protection Frost Setpoint	-50..150°C	R/W*3	8°C	Always exposed
AV	RmOccCO2Sp.RelDefault	Setpt CO2 Occ	0..3000ppm, 0..100%	R/W*3	1000 ppm	Intake Air Quality

Object	Object Name	Short Description	Range, Units, State Text	R/W	Safety/ Default Value	BACnet Visibility Rule
AV	RmOvrHtgSp.RelDefault	Temp Protection Over Heat Setpoint	-50..150°C	R/W*3	35°C	Always exposed
AI	RmRH.SensorOffset	Relative Humidity	-50..50%	R/W*3	0%	Terminal cfg, M/S
AI	RmTemp.SensorOffset	Space Temperature	-5..5°C	R/W*3	0°C	Terminal cfg, M/S
AV	RmUnOccCO2Sp.RelDefault	Setpt CO2 Unocc	0..3000ppm, 0..100%	R/W*3	2000 ppm	Intake Air Quality
AV	SaMaxTempSp.RelDefault	FCU Cascade follow ctrl Discharge Air Max Temp Setpt	-50..150°C	R/W*3	35°C	FCU Cas follow
AV	SaMinTempSp.RelDefault	FCU Cascade follow ctrl Discharge Air Min Temp Setpt	-50..150°C	R/W*3	17°C	FCU Cas follow
AI	SaTemp.SensorOffset	Discharge Temperature	-5..5°C	R/W*3	0°C	Terminal cfg
AV	StbyClgSp.RelDefault	Setpt Temp Clg Stby	-50..150°C	R/W*3	25°C	Space Temp Clg
AV	StbyHtgSp.RelDefault	Setpt Temp Htg Stby	-50..150°C	R/W*3	19°C	Space Temp Htg
PAR	SummerComp_Rst_Rng	Summer Compensation Increase	-50..999°C	R/W*1	9delta°C	Always exposed
PAR	UnFlr_Htg_Hi_Lim_Ctrl_Sp	Underfloor Htg High Limit, Setpt	-50..150°C	R/W*1	35°C	Underfloor Htg limit
PAR	UnFlr_Htg_Hi_Lim_Ctrl_Xp	Underfloor Htg High Limit, XP-Band	0..1000delta°C	R/W*1	3delta°C	Underfloor Htg limit
AI	UnFlrSupWtrTemp.SensorOffset	Underfloor Htg Supply Water Temperature	-5..5°C	R/W*3	0°C	Terminal cfg
AV	UnOccClgSp.RelDefault	Setpt Temp Clg Unocc	-50..150°C	R/W*3	28°C	Space Temp Clg
AV	UnOccHtgSp.RelDefault	Setpt Temp Htg Unocc	-50..150°C	R/W*3	16°C	Space Temp Htg
PAR	WM_Push_Button_Bypass_Time	WM Bypass Time	0..1080min	R/W*1	180min	Always exposed
PAR	WM_Sp_Calc_Occ_Sp_Shift_Rng	WM rel/abs Setpt shift during Occ	0..18delta°C	R/W*1	5delta°C	Always exposed
PAR	WM_Sp_Calc_Stby_Sp_Shift_Rng	WM rel/abs Setpt shift during Stby	0..18delta°C	R/W*1	5delta°C	Always exposed
PAR	WM_Sp_Calc_UnOcc_Sp_Shift_Rng	WM rel/abs Setpt shift during Unocc	0..18delta°C	R/W*1	0delta°C	Always exposed

*1 All BACnet objects with Object="PAR" are NOT allowed to write on it periodically, because these values are saved to the internal Flash. The number of write cycles is limited (<=3 cycles/day).

*3 Changes to these parameters (BV, AV, ... but not PAR) must be written to the properties "PresentValue" AND "RelinquishDefault" in order to write it to the flash. Do not write to these parameters periodically, see *1.

NOTE: PAR objects in this table are only available in RoomUp and via Niagara's N4 "Generic Parameter" component. They are not part of the EDE file. RoomUp supports local parameters which can be handled by each controller individually and independently from the same template used by all controllers. The local parameters can be changed via central such as the EBI and uploaded into RoomUp.

BACnet Information

For basic and detailed information on BACnet, please visit the following web sites:

www.bacnet.org
www.bacnetinternational.org
www.big-eu.org

Troubleshooting

For technical support, please contact the Honeywell Technical Assistance center.

<http://web.ge51.honeywell.de/tac/>

Manufactured for and on behalf of the Environmental and Energy Solutions Division of Honeywell Technologies Sàrl, Rolle, Z.A. La Pièce 16, Switzerland by its Authorized Representative:

Centraline
Honeywell GmbH
Böblinger Strasse 17
71101 Schönaich, Germany
Phone +49 (0) 7031 637 845
Fax +49 (0) 7031 637 740
info@centraline.com
www.centraline.com

Subject to change without notice
EN2Z-1015GE51 R0818

