

### GENERAL INFORMATION

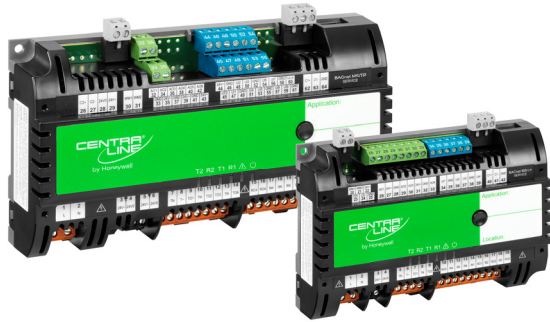


Fig. 1. CLMERxx (without optional covers)

### BEFORE INSTALLATION

#### IMPORTANT

It is recommended that the unit be kept at room temperature for at least 24 hours before applying power; this is to allow the evaporation of any condensation resulting from low shipping / storage temperatures.

US requirement, only: This device must be installed in a UL-listed enclosure offering adequate space to maintain the segregation of line voltage field wiring and Class 2 field wiring.



#### CAUTION

To avoid electrical shock or equipment damage, you must switch OFF the power supply before attaching / removing connections to/from any terminals.

Table 1. Overview of models

	OS no.: CLME...	power supply	AOs	UIs	BIs	relays (N.O.)	triacs (24 / 230 VAC)	total no. of I/Os	max. 24 VAC output
large housing (198 x 110 x 57.5 mm)	RL2	230 VAC	2	6	0	4	4	16	300 mA (or 320 mA for max. 2 minutes)
	RL6	24 VAC	6	10	0	4	4	24	600 mA
	RL8	230 VAC	6	6 <sup>(A)</sup>	4 <sup>(B)</sup>	4	4	24	300 mA (or 320 mA for max. 2 minutes)
small housing (162 x 110 x 57.5 mm)	RS4	230 VAC	4	4	0	4	2	14	300 mA (or 320 mA for max. 2 minutes)
	RS5	24 VAC	4	4	0	4	2	14	600 mA

<sup>(A)</sup> Of this model's six UIs, only two UIs support NTC; this model is thus not suitable for the hardwiring of wall modules requiring three UIs supporting NTC.

<sup>(B)</sup> In the case of this model, these binary-only inputs are labelled as UI1-UI4.

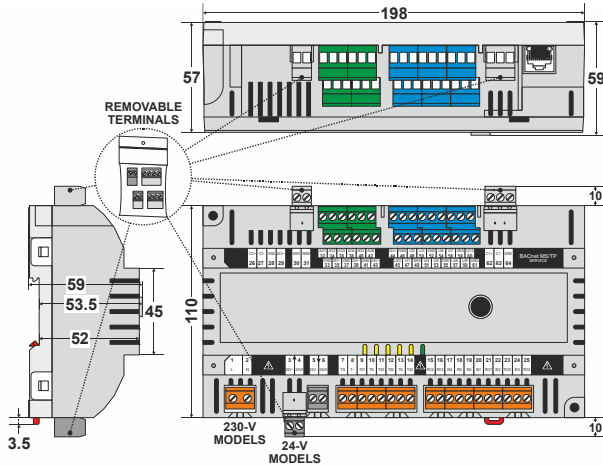
## DIMENSIONS AND MOUNTING

### Housings

The controller is available in two housing sizes, both conforming to IP20:

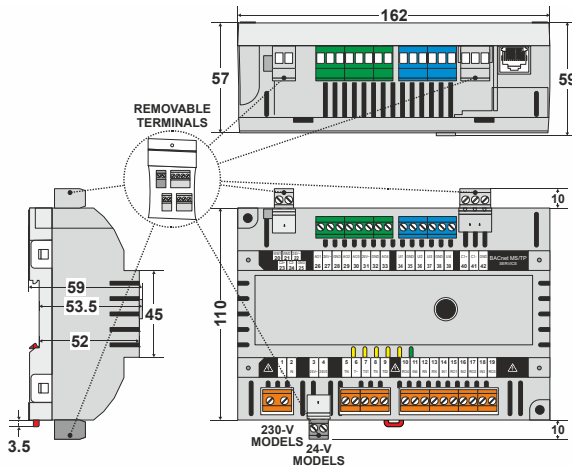
- RLx (large housing):  
W x L x H = 110 x 198 x 59 mm and
- RSx (small housing):  
W x L x H = 110 x 162 x 59 mm

See also Fig. 2 and Fig. 3.



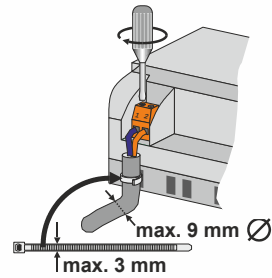
**Fig. 2. RLx dimensions (in mm)**

**NOTE:** In the case of the RL5, all of the terminal blocks are removable.



**Fig. 3. RSx dimensions (in mm)**

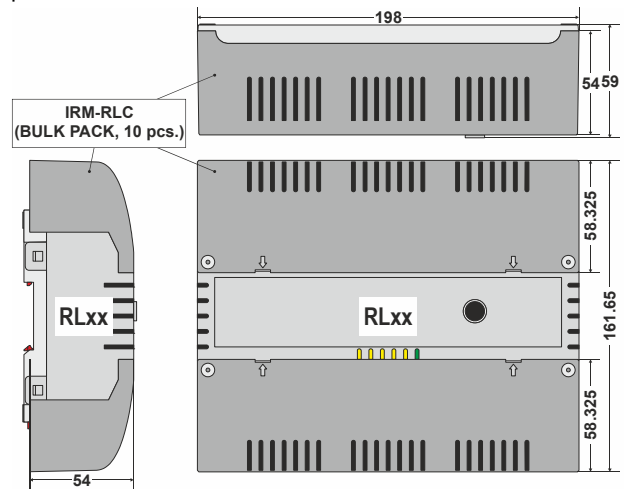
The unit is suitable for mounting on a standard rail, on walls, as well as in wiring cabinets or fuse boxes.



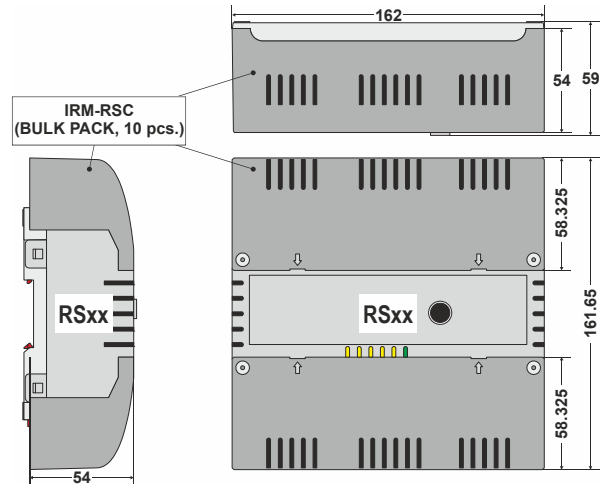
**Fig. 4. Cable binders**

### Terminal Protection Covers for IP30

In the case of controllers mounted outside of a cabinet, before applying power to the device, Terminal Protection Covers (10-pc. bulk packs, order no.: IRM-RLC for large housings and IRM-RSC for small housings) must be mounted so as to provide IP30.

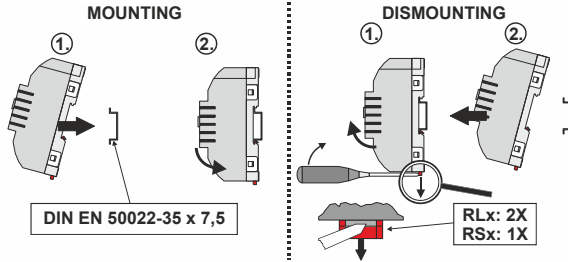


**Fig. 5. Large housing, with terminal protection covers, dimensions (in mm)**



**Fig. 6. Small housing, with terminal protection covers, dimensions (in mm)**

## DIN Rail Mounting/Dismounting



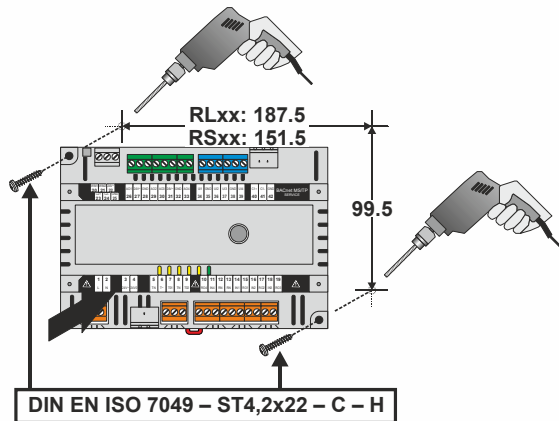
**Fig. 7. Mounting and dismounting**

The unit can be mounted onto the DIN rail simply by snapping it into place. It is dismounted by gently pulling the stirrup(s) located at the base of the housing (see Fig. 7). When mounted vertically on a DIN rail, the unit must be secured in place with a stopper to prevent sliding.

## Wall Mounting/Dismounting

The unit can be mounted on floors, walls, and ceilings in any desired orientation. (See also section "Ambient Environmental Limits" on pg. 21 for temperature range restrictions with floor/ceiling mounting.)

The unit is mounted by inserting optional screws (recommended: DIN EN ISO 7049 – ST4,2x22 – C – H) through the corresponding screwing noses.



**Fig. 8. Drilling template (view from above)**

After mounting the unit onto the wall, snap the appropriate terminal protection covers (see Fig. 5 and Fig. 6 on pg. 2) into place onto the housing by hand.

**NOTE:** In the case of wall-mounting, optional terminal protection covers (in the case of the RLx [large housings]: IRM-RLC; in the case of the RSx [small housings]: IRM-RSC) must be installed in order to comply with IP30.

The covers can be fixed into place using optional screws (recommended: DIN EN ISO 7049 – ST2,9x9,5 – C (F) – H). To remove a cover, place a screwdriver in the two leverage slots (marked with arrows) and pry it loose.

## TERMINAL ASSIGNMENT

### General

For a complete list of all terminals and a description of their functions, see Table 2 and Table 6.

**NOTE:** All terminal blocks capable of carrying either low voltage or line voltage are orange-colored.

The delivery includes a plastic bag containing additional, removable terminal blocks for BACnet MS/TP and Sylk interfaces.

The controller is powered by 230 VAC, and is equipped with differing numbers of triac outputs, relay outputs, etc. capable of being configured in a variety of ways. See Table 1 on page 1.

Every controller features a terminal assignment label on the top of the housing.

### Power Supply Terminals

- Power is supplied via an orange-colored fixed screw-type terminal block (terminals 1+2).

See also section "Power Supply" on pg. 11.

### Input / Output Terminals

The controller features rows of terminal blocks on the top and bottom.

- In the case of the RLx (large housing), the controller has double rows of analog outputs (AOs) and universal inputs (UIs) at the top and a single row of binary outputs (BOs) - triacs (TRs) and relay outputs (ROs) - at the bottom.
- In the case of the RSx (small housing), the controller has a single row of analog outputs (AOs) and universal inputs (UIs) at the top and a single row of binary outputs (BOs) - triacs (TRs) and relay outputs (ROs) - at the bottom.

**NOTE:** According to VDE guidelines, it is not allowed to mix low-voltage and high-voltage signals on the relays and triacs.

See also section "I/O Terminals" on pg. 16.

### Communication Interfaces

All models of the controller feature the following communication interfaces:

- A Sylk Bus interface (removable plug; RSx: terminals 20 and 21; RLx: terminals 30 and 31), for connection to CLCMTR40x/42x Wall Modules;
- A BACnet MS/TP interface (removable plug; RSx: terminals 40, 41, and 42; RLx: terminals 62, 63, and 64);
- An RJ45 connector for connection of the BACnet WiFi Adapter.

**Table 2. RSxx Room Controller: Overview of terminals and functions**

term.	printing	function	RS4	RS5
1, 2	"L", "N"	Power supply (230 VAC)	X	--
3, 4	"24V~", "24V0"	230V models: aux. output voltage (24 VAC) for all triacs; 24V models: power supply (24 VAC) and aux. output voltage (24 VAC) for all triacs	X	X
5	"TN"	Aux. term. for triac neutral wiring (internally connected with terminal 8)	X	X
6	"T~"	Triac input voltage (24 VAC / 230 VAC) for all triacs; triac-switched	X	X
7	"T01"	Triac-switched output	X	X
8	"TN"	Aux. term. for triac neutral wiring (internally connected with terminal 5)	X	X
9	"T02"	Triac-switched output	X	X
10, 11	"RO4", "IN4"	Output of Relay 4, Input for Relay 4	type 2	type 2
12, 13	"RN", "RN"	Aux. terminals for relay neutral wiring	X	X
14, 15	"IN1", "RO1"	Input for Relay 1, Output of Relay 1	type 1	type 1
16, 17	"IN2", "RO2"	Input for Relay 2, Output of Relay 2	type 1	type 1
18, 19	"IN3", "RO3"	Input for Relay 3, Output of Relay 3	type 1	type 1
20, 21	"WM1", "WM2"	Removable interface for Sylk Bus	X	X
22, 23, 24, 25	"24V~", "C2+", "C2-", "24V0"	Not used.	--	--
26	"AO1"	Analog Output 1	type 2	type 2
27	"24V~"	24 VAC power for field devices	X	X
28	"GND"	Ground for AOs	X	X
29	"AO2"	Analog Output 2	type 1	type 1
30	"AO3"	Analog Output 3	type 1	type 1
31	"24V~"	24 VAC power for field devices	X	X
32	"GND"	Ground for AOs	X	X
33	"AO4"	Analog Output 4	type 1	type 1
34	"UI1"	Universal Input 1	type 1	type 1
35	"GND"	Ground for UIs	X	X
36	"UI2"	Universal Input 2	type 1	type 1
37	"UI3"	Universal Input 3	type 1	type 1
38	"GND"	Ground for UIs	X	X
39	"UI4"	Universal Input 4	type 1	type 1
40, 41, 42	"C1+", "C1-", "GND"	Removable BACnet MS/TP interface and corresponding GND	X	X

Relay output types: See Table3. Universal input types: See Table 4. Analog output types: See Table 5

**Table 3. Relay output types and characteristics**

	type 1 (standard)	type 2 (high in-rush current)
corresponding ROs of RSxx	RO1, RO2, RO3	RO4
corresponding ROs of RLxx	RO2, RO3	RO1, RO4
contact	N.-O.	N.-O.
min. load	5 VAC, 100 mA	24 VAC, 40 mA
switching voltage range	15 ... 253 VAC	15 ... 253 VAC
max. continuous load at 250 VAC (cos φ = 1)	4 A	10 A
max. continuous load at 250 VAC (cos φ = 0.6)	4 A	10 A
in-rush current (20 ms)	--	80 A
usage	fan motor	light switching and fan motor

**NOTE:** The max. sum load of all relay currents at the same time is 14 A.

**Table 4. Universal input types and characteristics**

	type 1	type 2	type 3
	UI1, UI2, UI3, UI4, UI5, UI6	UI7, UI8, UI9, UI10	UI1, UI2, UI3, UI4 (RL8, only)
Dry contact (closed: res. <10 kΩ; open: res. > 20 kΩ; max. 0.2 Hz; pull-up voltage: 10 V)	X	X	--
Dry contact (closed: res. <10 kΩ; open: res. > 20 kΩ; max. 0.2 Hz; pull-up voltage: 24 V); suitable for light switch applications	--	--	X
Fast binary (=counter) input (max. 30 Hz; pulse ON = min. 16 ms; pulse OFF = min. 16 ms; closed: voltage < 1 V; open: voltage > 5 V; pull-up voltage: 10 V)	X	X	--
Fast binary (=counter) input (max. 30 Hz; pulse ON = min. 16 ms; pulse OFF = min. 16 ms; closed: voltage < 1 V; open: voltage > 5 V; pull-up voltage: 24 V)	--	--	X
0(2) ... 10 V	X	X	--
NTC20kΩ	X	--	--
SetPoint and FanSpdSW (from CLCM1T,2T,4T,5T,6T111)	X	--	--
NTC10kΩ	X	--	--
PT1000 + Ni1000TK5000	--	X	--

**Table 5. Analog output types and characteristics**

	type 1	type 2	type 3	type 4	type 5
output voltage	0...11 V				
output current	0...1 mA	0...5 mA	0...10 mA	0...20 mA	-1...+1 mA
min. accuracy	±150 mV				
max. ripple	±100 mV				
accuracy at zero point	0...200 mV				±150 mV

**Table 6. RLxx Room Controllers: Overview of terminals and functions (by model)**

term.	printing	function	RL2	RL6	RL8
1, 2	"L", "N"	Power supply (230 VAC)	X	--	X
3, 4	"24V~", "24V0"	Power supply (24 VAC)	--	X	--
5, 6	"24V~", "24V0"	Aux. output voltage (24 VAC) for all triacs	X	X	X
7	"TN"	Aux. terminal for triac neutral wiring (internally connected with terminals 10 + 13)	X	X	X
8	"T~"	Triac input voltage (24 VAC / 230 VAC) for all triacs; triac-switched	X	X	X
9	"T01"	Triac-switched output	X	X	X
10	"TN"	Aux. terminal for triac neutral wiring (internally connected with terminals 7 + 13)	X	X	X
11	"T02"	Triac-switched output	X	X	X
12	"T03"	Triac-switched output	X	X	X
13	"TN"	Aux. terminal for triac neutral wiring (internally connected with terminals 7 + 10)	X	X	X
14	"T04"	Triac-switched output	X	X	X
15	"RC4"	Not used.	--	--	--
16, 17	"RO4", "IN4"	Output of Relay 4, Input for Relay 4	type 2	type 2	type 2
18	"RN"	Aux. terminal for relay neutral wiring	X	X	X
19	"RN"	Aux. terminal for relay neutral wiring	X	X	X
20, 21	"IN1", "RO1"	Input for Relay 1, Output of Relay 1	type 2	type 2	type 2
22, 23	"IN2", "RO2"	Input for Relay 2, Output of Relay 2	type 1	type 1	type 1
24, 25	"IN3", "RO3"	Input for Relay 3, Output of Relay 3	type 1	type 1	type 1
26, 27, 28, 29	"C2+", "C2-", "24V0", "24V~"	Not used.	--	--	--
30, 31	"WM1", "WM2"	Removable interface for Sylk Bus	X	X	X
32	"AO1"	Analog Output 1	type 3	type 3	type 4
33	"GND"	Ground for AOs	X	X	X
34	"AO2"	Analog Output 2	type 3	type 3	type 3
35	"24V~"	24 VAC power for field devices	X	X	X
36	"AO3"	Analog Output 3	--	type 1	type 5
37	"GND"	Ground for AOs	--	X	X
38	"AO4"	Analog Output 4	--	type 1	type 5
39	"24V~"	24 VAC power for field devices	--	X	X
40	"AO5"	Analog Output 5	--	type 1	type 1
41	"GND"	Ground for AOs	--	X	X
42	"AO6"	Analog Output 6	--	type 1	type 1
43	"24V~"	24 VAC power for field devices	--	X	X
44	"24V~"	24 VAC power for field devices	X	--	X
45	"LED"	Output to LED of CLCM4T,5T,6T111	X	--	X
46	"GND"	Ground for UIs	X	X	X
47	"UI1"	Universal Input 1	type 1	type 1	type 3 (BI)
48	"UI2"	Universal Input 2	type 1	type 1	type 3 (BI)
49	"GND"	Ground for UIs	X	X	X
50	"UI3"	Universal Input 3	type 1	type 1	type 3 (BI)
51	"UI4"	Universal Input 4	type 1	type 1	type 3 (BI)
52	"GND"	Ground for UIs	X	X	X
53	"UI5"	Universal Input 5	type 1	type 1	type 1
54	"UI6"	Universal Input 6	type 1	type 1	type 1
55	"GND"	Ground for UIs	X	X	X
56	"UI7"	Universal Input 7	--	type 2	type 2
57	"UI8"	Universal Input 8	--	type 2	type 2
58	"GND"	Ground for UIs	--	X	X
59	"UI9"	Universal Input 9	--	type 2	type 2
60	"UI10"	Universal Input 10	--	type 2	type 2
61	"GND"	Ground for UIs	--	X	X
62, 63, 64	"C1+", "C1-", "GND"	Removable BACnet MS/TP interface and corresponding GND	X	X	X

Relay output types: See Table3. Universal input types: See Table 4. Analog output types: See Table 5

\*OPTIONAL FUSE (TO PROTECT CONTROLLER'S INTERNAL TRANSFORMER, WHICH HAS ONLY A NON-RESETTABLE FUSE)

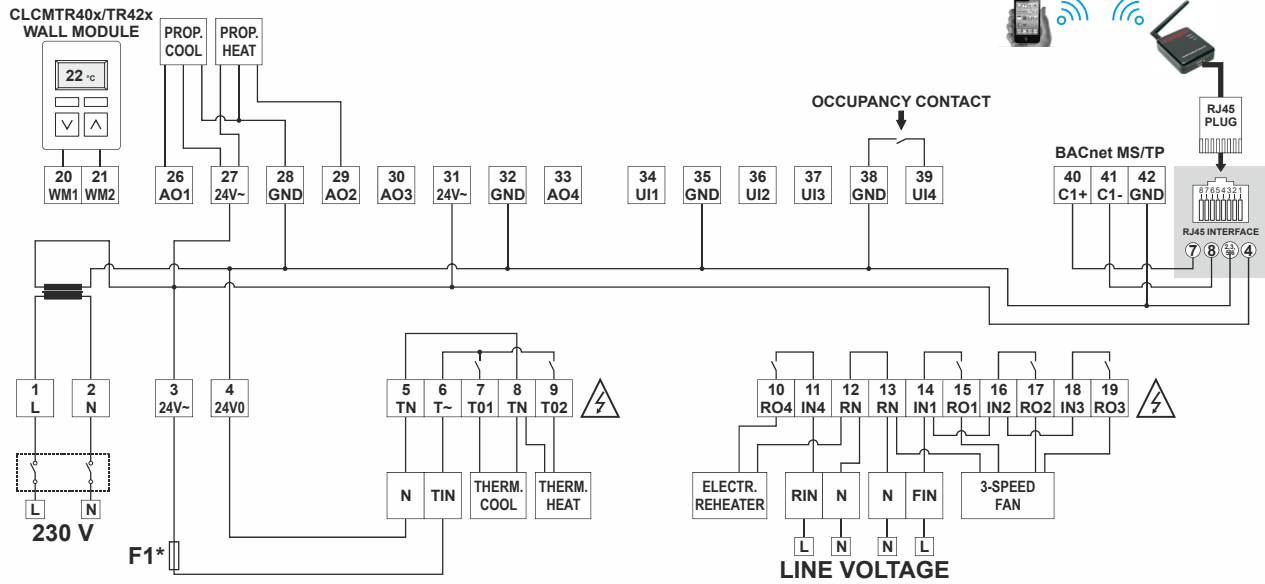


Fig. 9. RS4 example wiring (230-V model)

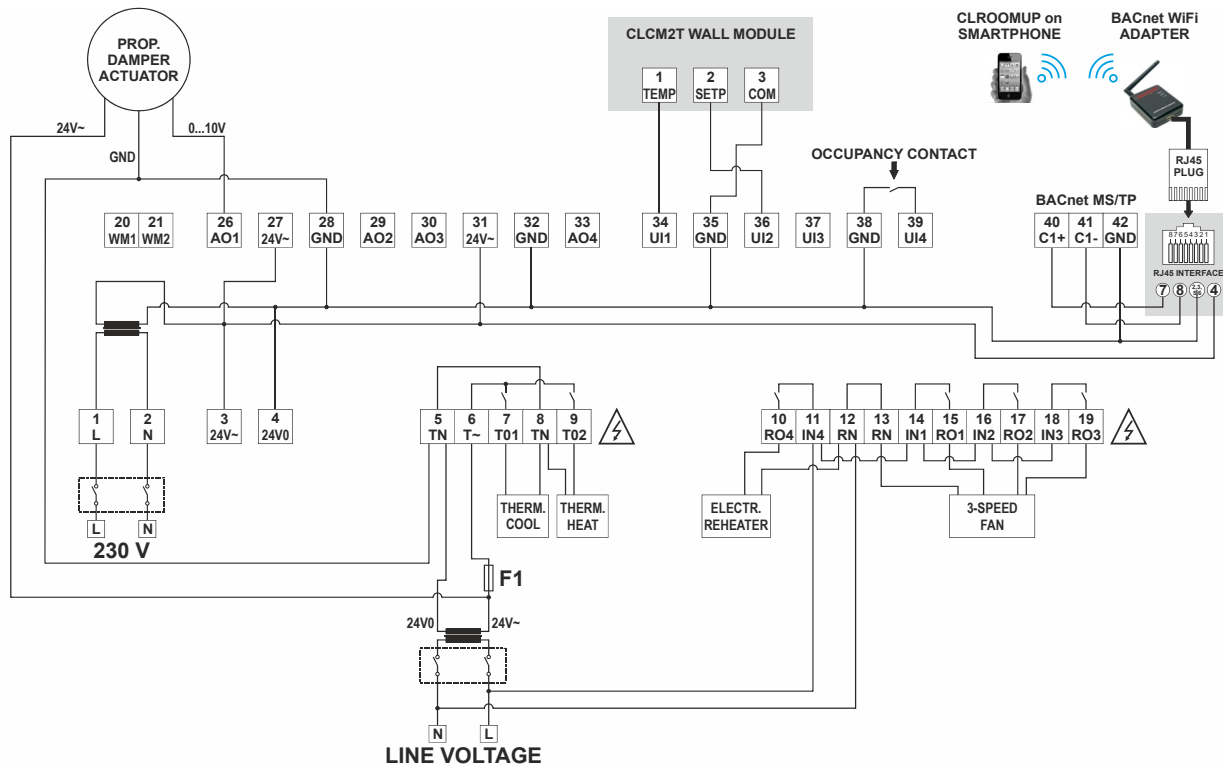
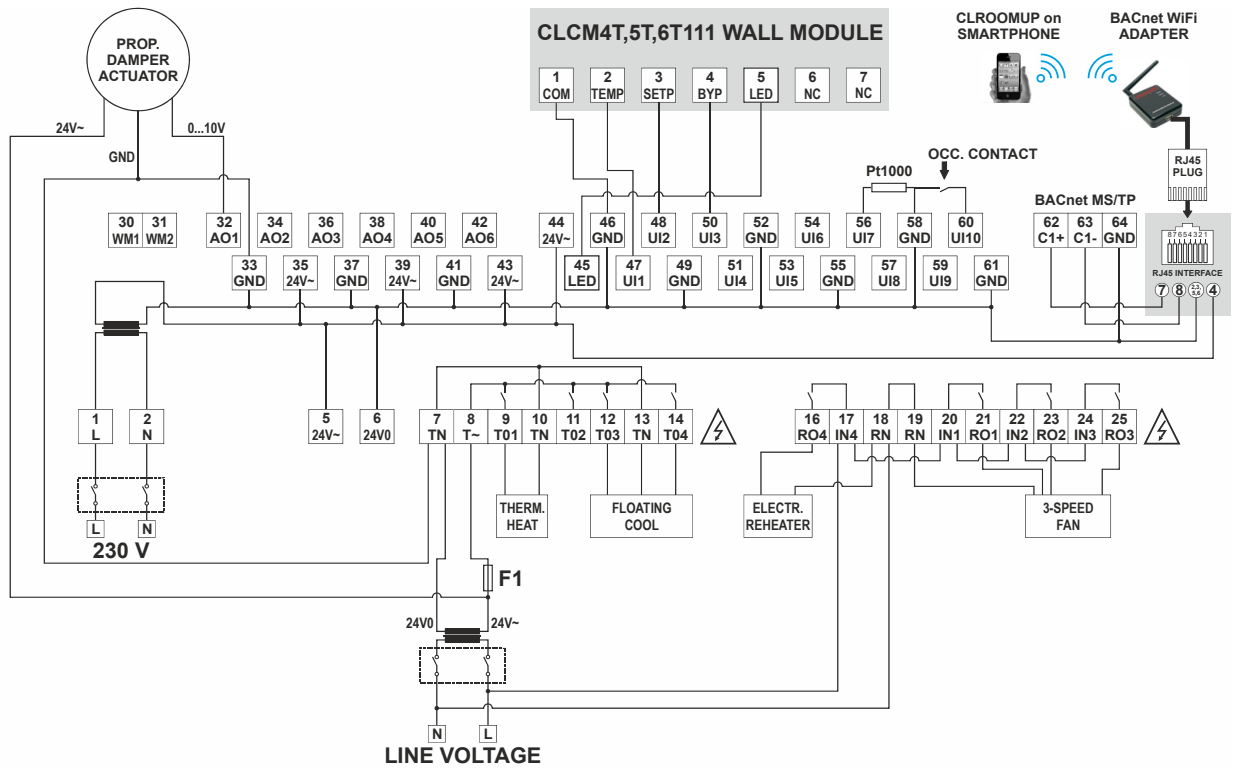
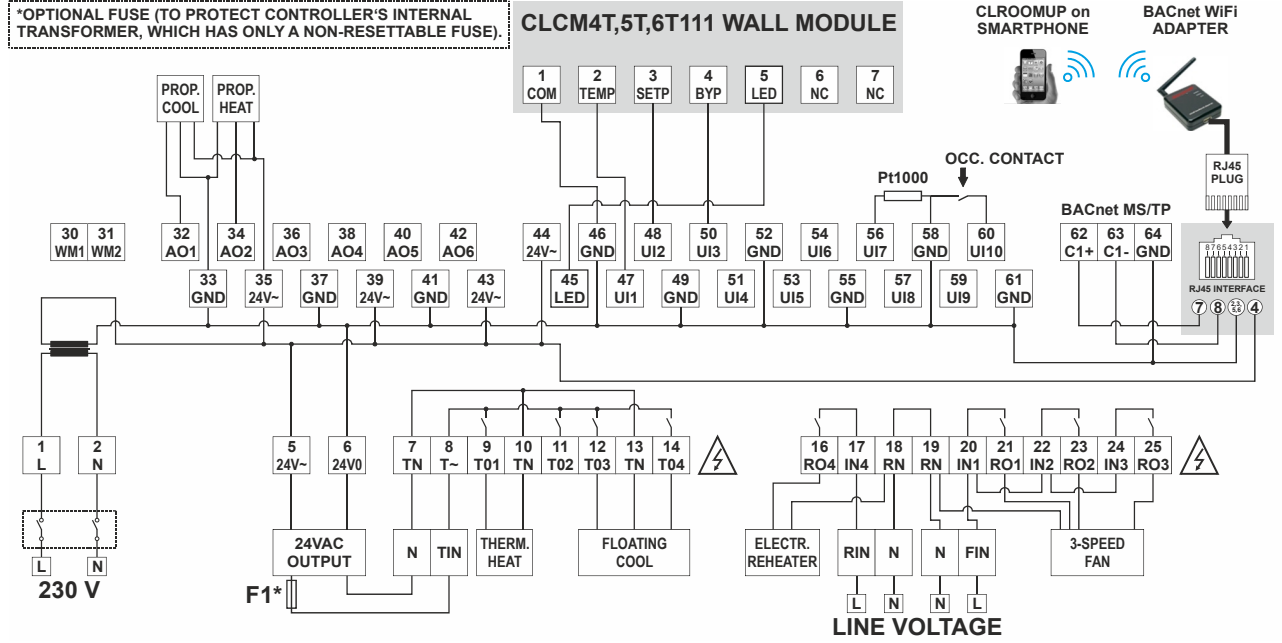


Fig. 10. RS4 example wiring (230-V model) (with actuator powered by extra transformer)





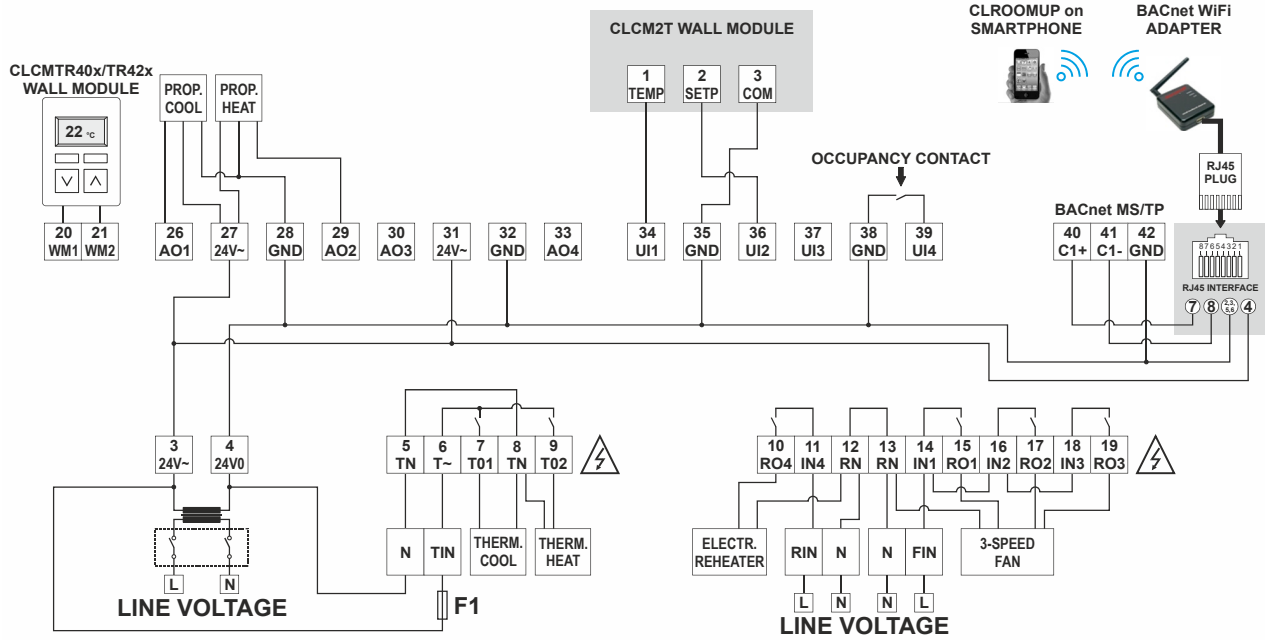


Fig. 13. RS5 (24-V model) example wiring

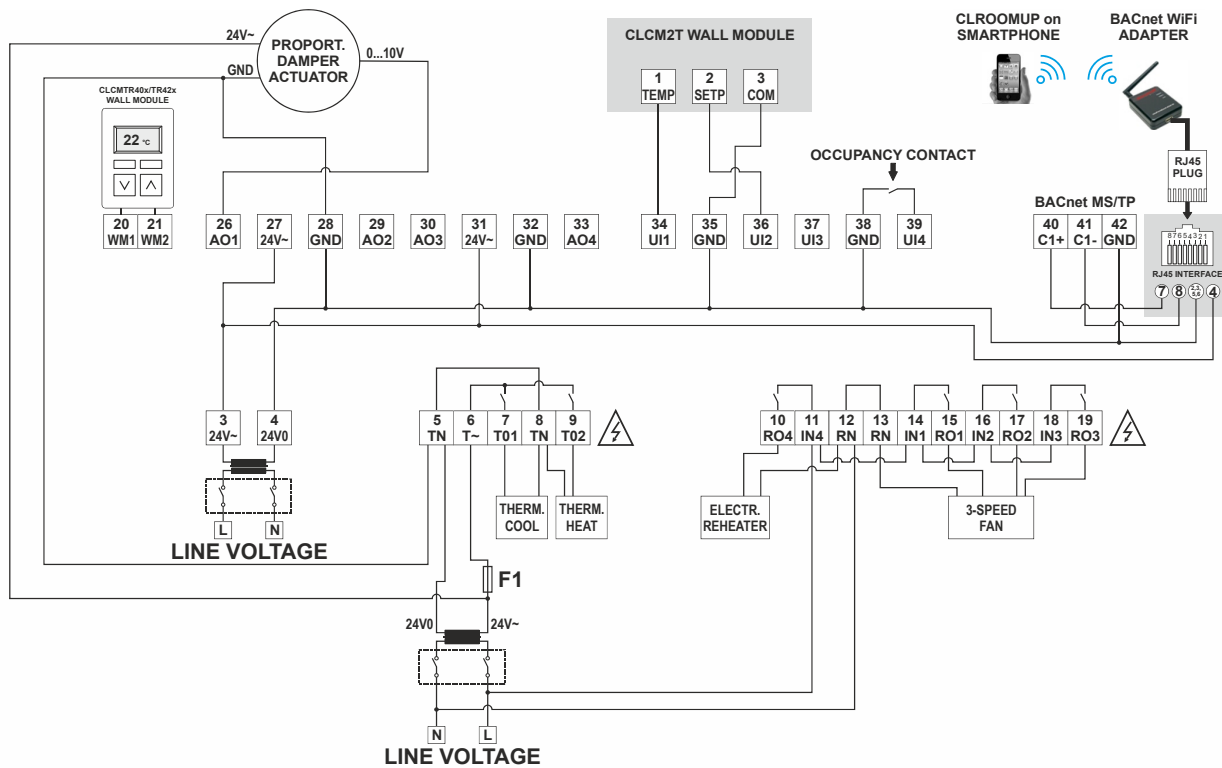


Fig. 14. RS5 (24-V model) example wiring (with actuator powered by extra transformer)

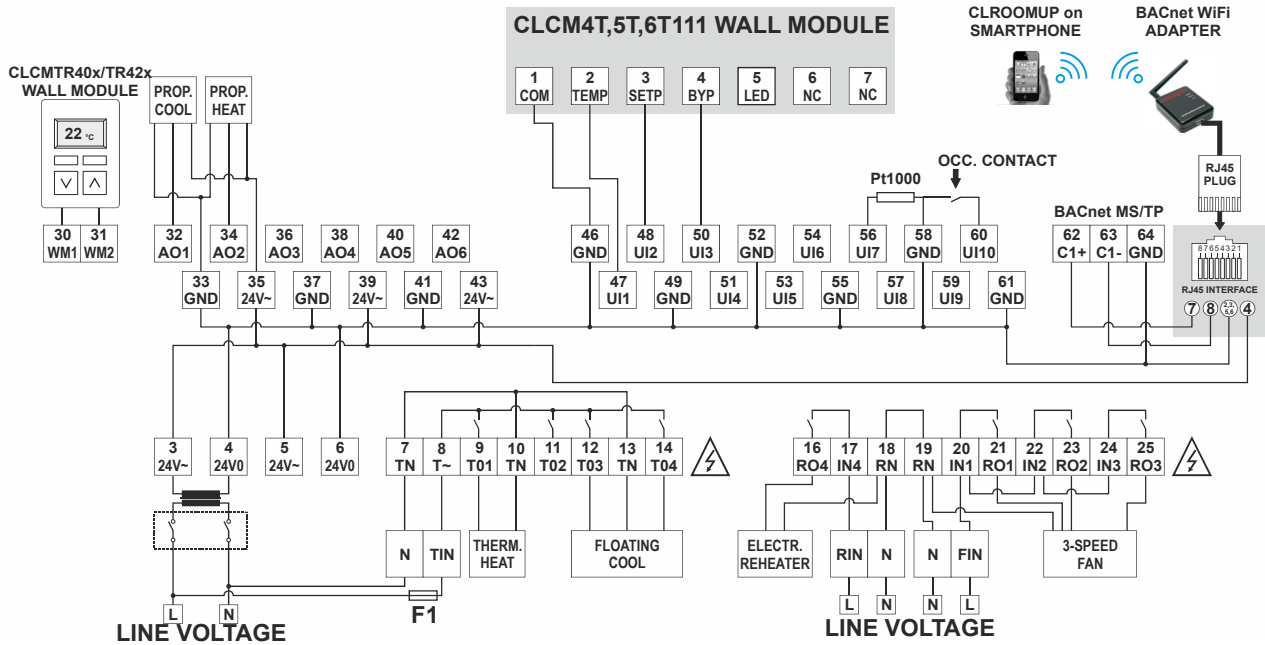


Fig. 15. RL6 (24-V model) example wiring

## POWER SUPPLY

### General Information

#### CAUTION

To prevent a risk of injury due to electrical shock and/or damage to device due to short-circuiting, low-voltage and high-voltage lines must be kept physically separate from one another.

Further, to prevent a risk of short-circuiting and damage to your unit, do not reverse the polarity of the power connection cables, and avoid ground loops (i.e., avoid connecting one field device to several controllers).

**NOTE:** All wiring must comply with applicable electrical codes and ordinances. Refer to job or manufacturers' drawings for details. Local wiring guidelines (e.g., IEC 364-6-61 or VDE 0100) may take precedence over recommendations provided in these installation instructions.

**NOTE:** To comply with CE requirements, devices having a voltage of 50...1000 VAC or 75...1500 Vdc but lacking a supply cord, plug, or other means for disconnecting from the power supply must have the means of disconnection (with a contact separation of at least 3 mm at all poles) incorporated in the fixed wiring.

### Wiring

#### 230-VAC Models

The 230-VAC models are powered via an orange fixed screw-type terminal block (terminals 1+2). See also Fig. 16. These terminals support 1 x 4 mm<sup>2</sup> or 2 x 2.5 mm<sup>2</sup> wiring.

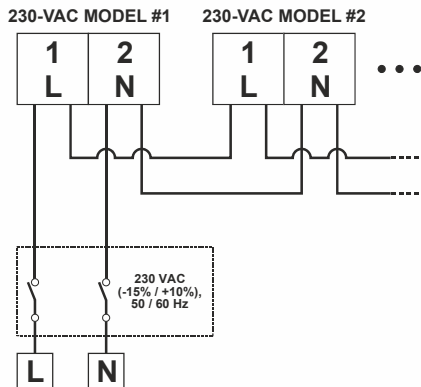


Fig. 16. Multiple 230-VAC models connected to single power supply

#### 24-VAC Terminals for Auxiliary or Field Devices

All 24-VAC auxiliary power supply terminals support 1 x 2.5 mm<sup>2</sup> or 2 x 1.5 mm<sup>2</sup> wiring.

#### 24-VAC Models

The 24-VAC models are powered via a black removable terminal plug (terminals 3+4), thus allowing daisy chain wiring

of the power supply. See also Fig. 17. These terminals support 1 x 2.5 mm<sup>2</sup> or 2 x 1.5 mm<sup>2</sup> wiring.

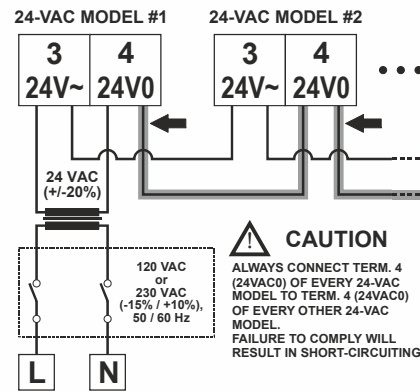


Fig. 17. Multiple 24-VAC models connected to single power supply

### Communication / Signal Terminals

All other (i.e.: communication / signal) terminals (except for the Syk Bus – see Table 12) support 1 x 2.5 mm<sup>2</sup> or 2 x 1.5 mm<sup>2</sup> wiring. Two wires with a total thickness of 2.5 mm<sup>2</sup> (14 AWG) can be twisted together and connected using a wire nut (include a pigtail with this wire group and attach the pigtail to the individual terminal block). Deviations from this rule can result in improper electrical contact. Local wiring codes may take precedence over this recommendation.

### Electrical Data

#### RL2, RL8, RS4 (230 VAC)

Power via terminals 1 + 2: 230 VAC +10% / -15%, 50/60 Hz.

Max. power consumption (when unloaded): 8 W.

Max. power consumption (when loaded): 18 W.

The controller is "unloaded" when it has no external load. Thus, the only load on the controller is the inherent load (8 W) of the electronics, themselves. The heat dissipation then amounts to 8 W. The controller is "loaded" when – besides the inherent load – an additional sum load resulting from max. **300 mA** (irrespective as to whether it is supplied by the controller's internal transformer or by an external source) is applied to the 24 VAC output terminals. The max. unloaded output voltage at terminals 3 and 4 (RSxx) or terminals 5 and 6 (RLxx), respectively, is 33 VAC (typically: 29.5 VAC).

#### RL6, RS5 (24 VAC)

Power via terminals 3+4: 24 VAC ±20%, 50/60 Hz.

Max. current consumption (when unloaded): 300 mA.

Max. current consumption (when loaded): 900 mA.

The controller is "loaded" when – besides the inherent load (300 mA) – an additional sum load resulting from max. **600 mA** is applied to the 24 VAC output terminals. The max. unloaded output voltage at terminals 3 and 4 (RSxx) or terminals 5 and 6 (RLxx) is identical with the output voltage of the external supplying transformer.

## COMMISSIONING

### Configurable Application

All models can be used with the configurable application already included in the controller.

The configurable application has the advantage that it is proven and quickly commissioned using the CLROOMUP commissioning tool running on an Android Smart device.

Configuration and commissioning can be performed using the CLROOMUP commissioning tool available in the Google Playstore (URL: <https://play.google.com/store> ).

**NOTE:** Before configuring, if as yet no WLAN is present, the commissioning engineer will require a BACnet WiFi Adapter (order no.: BACA-A) to establish wireless communication between his Android Smart device and the controller.

### Automatic MAC Addressing

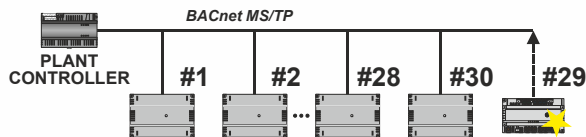
In contrast to other controllers (e.g., LYNX controllers, whose MAC addresses must be assigned manually), the Rxx Controller features automatic MAC addressing.

The MAC addresses which the individual Rxx controllers on the BACnet MS/TP bus assign to themselves are not assigned in sequential order.



They assign those numbers (MAC ID) between 1...30 currently not in use by another device on the BACnet MS/TP bus. All Rxx controllers are BACnet MS/TP masters. Every master performs periodic polling for the possible appearance of new masters. Each master "knows" the identity of the "next" master (i.e., that Rxx controller with the next-highest MAC ID) on the BACnet MS/TP bus and to which it must therefore pass the token. The polling process includes a search for new masters which might have MAC addresses lying between its own MAC address and that of the "next" master. The value of the property Max Master specifies the highest-allowable address for master nodes. Max Master is set to 35 by default, thus guaranteeing that, on a BACnet MS/TP bus with, e.g., 30 Rxx controllers, all of the other Rxx controllers will be found. Both the property Max Master and the property MAC ID are writeable properties that can be changed. Specifically: "MAC ID" can be changed using CLROOMUP, while "Max Master" can be changed using CLROOMUP or any other BACnet-compatible engineering tools, e.g., with BACShark.

**NOTE:** It is not possible to configure a MAC ID outside the range of 1...30.

See also CARE User Guide (Product Literature No.: EN2B-0182GE51) or EAGLE – Communication Interfaces (EN2Z-1002GE51) for detailed information.



**LEGEND:**

-  = NON-Rxx CONTROLLER (WITH MANUAL MAC ADDRESSING)
-  = Rxx (WITH AUTOMATIC MAC ADDRESSING)

**Fig. 18. Automatic MAC addressing (scenario "A")**

In scenario "A", 29 controllers with manually-assigned MAC addresses (#1, #2, #3...#27, #28, #30 – MAC address #29 has thus been deliberately skipped) are already up and running on the BACnet MS/TP bus. A single additional Rxx is then connected to the bus and powered on.

**RESULT:** The Rxx Controller requires approx. 28-31 sec to automatically assign itself a compatible MAC address (#29), and to complete various other firmware tasks before becoming fully operational.

Scenario "A" and additional scenarios ("B" through "F") are described in Table 7 below.

**Table 7. Possible Auto MAC addressing scenarios**

scenario	time	remarks
A: Rxx start-up time on single BACnet MS/TP bus after power-on (cold boot or reset).	28-31 sec	29 non-Rxx controllers (with manual MAC addressing) are running; 1 Rxx is then added and powered on.
B: Average start-up time for all Rxx controllers on single BACnet MS/TP bus.	1 min. and 34 sec	Like "A," but with 8 non-Rxx controllers; 22 Rxx controllers are then added and booted.
C: Time to recognize conflicting MAC address of added non-Rxx controller.	21 sec	Like "B," but with 7 non-Rxx controllers and 22 Rxx controllers; an additional non-Rxx controller with a conflicting address is then added.
D: Time to recognize conflicting MAC address of added non-Rxx controller while auto MAC still in progress.	50 sec	Like "C," but with the additional non-Rxx controller having a conflicting MAC address added while auto MAC still in progress.
E: Time for auto MAC when additional Rxx controllers are added in stages while auto MAC still in progress.	30 sec	Like "B," but with Rxx controllers added in stages.
F: Time for restart of Rxx controllers and verification of auto MAC addresses after power-down.	17 sec	8 non-Rxx controllers and 22 Rxx controllers are running; then power-down and restart.

## OPERATOR INTERFACES

### LEDs

The controller features the following LEDs:



Fig. 19. Controller LEDs

Table 8. Description of LED behaviors

symbol	color	function, description
T2	yellow	Not used
R2	yellow	Not used
T1	yellow	LED indicating transmission of communication signals via the BACnet MS/TP interface.
R1	yellow	LED indicating reception of communication signals via the BACnet MS/TP interface.
△	yellow	Status LED indicating firmware problems, hardware problems, etc. (see Table 9).
⏻	green	Power LED indicating firmware problems, hardware problems, etc. (see Table 9).
	red	Not used.

Table 9. Status LED and power LED behaviors

#	Mode	Power LED (green)	Status LED (yellow)
1	Power failure	Stays OFF	Stays OFF
2	Normal operation	ON/OFF (0.5 Hz)	Stays OFF
3	No firmware	ON/OFF (0.5 Hz)	ON/OFF (1 Hz)
4	No valid MAC	ON/OFF (0.5 Hz)	ON/OFF (0.5 Hz)
5	Auto-MAC	ON/OFF (1 Hz)	ON/OFF (0.5 Hz)
6	No application	ON/OFF (0.5 Hz)	ON/OFF (0.25 Hz)
7	Short-circuiting	ON/OFF (0.5 Hz)	Stays ON
8	Broken sensor	ON/OFF (0.25 Hz)	Stays ON
9	Device error*	Stays ON	Stays ON

\*Please return the controller for repair (all of the software is missing).

### Service Button

The Service Button is used to trigger dedicated events.

Table 10. Use of controller's Service Button

action	result
Button pressed 0.01 to 2 sec. while controller running	Service Pin (UID) broadcast on the BACnet MS/TP bus.
Button pressed > 10 sec. while controller powering up	Password is reset.
Button pressed 0.01 to 5 sec. while controller powering up	Auto MAC addressing procedure reinitiated.

## COMMUNICATION INTERFACES

### BACnet MS/TP Interface

The controller features an RS485 interface (RLx: terminals 62, 63, and 64; RSx: terminals 40, 41, and 42) suitable for BACnet MS/TP communication. The terminal block containing it is black. The cable length affects the baud rate. See Table 11.

**Table 11. Baud rate vs. max. cable length**

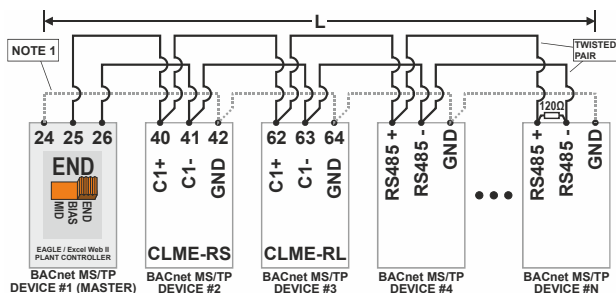
baud rate	max. cable length (L)
9.6, 19.2, 38.4, 57.6, and 76.8 kbps	1200 m
115.2 kbps	800 m

For information on wire gauge, max. permissible cable length, possible shielding and grounding requirements, and the max. number of devices which can be connected to a bus, refer to standard EIA-485.

### Connecting to BACnet MS/TP Buses

The controller communicates via its BACnet MS/TP interface with other BACnet MS/TP-capable devices (e.g., other room controllers or plant controllers like the EAGLE / Excel Web II). In doing so, the following considerations should be taken into account.

- Max. BACnet MS/TP bus length (L): See Table 11.
- Twisted-pair cable, e.g.:
  - AWG 18;
  - J-Y-(St)-Y 2 x 2 x 0,8;
  - CAT 5,6,7 cable – use only one single pair for one bus;
  - Belden 9842 or 9842NH);
 and daisy-chain topology.
- Must conform to EIA-RS485 cabling guidelines and ANSI/ASHRAE Standard 135-2010.
- Max. no. of BACnet MS/TP devices (including the Master) per BACnet MS/TP channel: 31 (= "N" in Fig. 20).



**Fig. 20. Connection to a BACnet MS/TP Bus**

- NOTE 1:** If any of the devices are electrically isolated, it is recommended that those devices be connected to signal ground.
- NOTE 2:** The 120-Ohm termination resistor must be inserted directly into the terminals of the final BACnet MS/TP device.
- NOTE 3:** If shielding is used, the shielding of each individual bus segment should be separately connected at one end to earth.

For details, see also:

- EAGLE – Installation Instructions (EN1Z-0970GE51) or
- Excel Web II – Installation Instr. (EN1B-0555GE51).

### RJ45 Connector for BACnet WiFi Adapter

A BACnet WiFi Adapter can be connected to the controller's RJ45 connector in order to establish wireless communication with an Android Smart device so that the application engineer can configure the controller (using the CLROOMUP configuration tool).

- NOTE:** If the BACnet WiFi Adapter is connected to the controller's RJ45 connection, it is powered by the controller. It is then prohibited to simultaneously power the BACnet WiFi Adapter via a wall adapter. If the BACnet WiFi Adapter is instead connected to the controller's BACnet MS/TP interface, it is prohibited to simultaneously use an RJ45 plug; rather, the BACnet WiFi Adapter must then be powered by a wall adapter (standard 5-V USB wall adapter with micro USB connector).

See also corresponding Technical Literature listed in Table 14 on pg. 21.

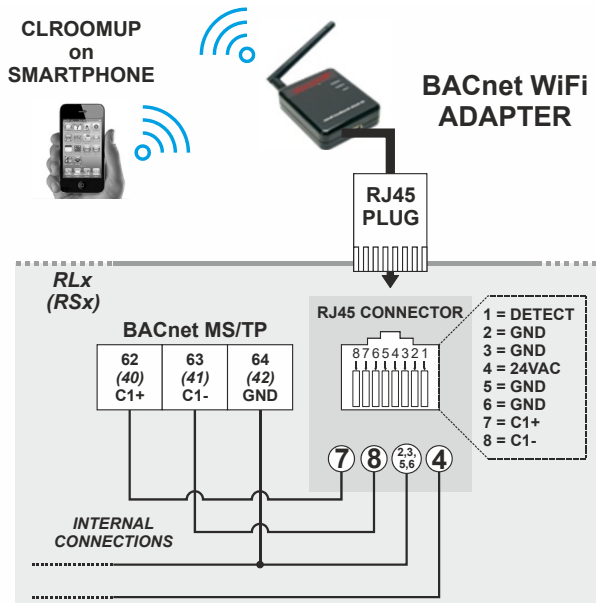


Fig. 21. RJ45 interface and BACnet WiFi Adapter

## ! CAUTION

It is permitted to connect **only** the BACnet WiFi Adapter to this RJ45 connector. Do **not** connect IP!

## Sylk Bus

Sylk Bus-capable devices (e.g., the CLCMTR40x/T42x) can be connected to the controller's Sylk Interface (RSx: terminals 20 and 21; RLx: terminals 30 and 31). Specifically:

- A max. of one wall module can be connected.
- The Sylk Bus is single pair, and polarity-insensitive.
- Max. current provided at the Sylk Bus interface: 96 mA.

Table 12. Recommended max. distances from controller to CLCMTR40x/T42x wall modules

no.	single twisted pair, non-shielded, stranded or solid <sup>A)</sup>		standard non-twisted thermostat wire, shielded or non-shielded, stranded or solid <sup>B), C)</sup>
	0.33...0.82 mm <sup>2</sup> (18...22 AWG)	0.20 mm <sup>2</sup> (24 AWG)	0.20...0.82 mm <sup>2</sup> (18...24 AWG)
2	150 m (500 ft)	120 m (400 ft)	30 m (100 ft)

<sup>A)</sup> As a rule of thumb, single twisted pair (two wires per cable, only), thicker gauge, non-shielded cable yields the best results for longer runs.  
<sup>B)</sup> The 30 m (100 ft) distance for standard thermostat wire is conservative, but is meant to reduce the impact of any sources of electrical noise (incl. but not limited to VFDs, electronic ballasts, etc.). Shielded cable recommended only if there is a need to reduce the effect of electrical noise.  
<sup>C)</sup> These distances apply also for shielded twisted pair.

## I/O TERMINALS



### CAUTION

Failure to observe the following max. permissible current outputs of the power output terminals will result in damage to the device.

### Max. Current Output of Power Output Terminals of 230 VAC Controllers

The 24 VAC power output terminals of the 230 VAC RLxx controllers are terminals 5, 6, 35, 39, 43, and 44 plus pin 4 of the controller's RJ45 interface. Two of these terminals (typically: 5 and 6) will be used to supply the triacs.

The 24 VAC power output terminals of the 230 VAC RSxx controllers are terminals 3, 4, 27, and 31 plus pin 4 of the controller's RJ45 interface. Two of these terminals (typically: 3 and 4) will be used to supply the triacs.

Regardless of whether the triacs are supplied by the controller's internal transformer or by an external source, the max. permissible combined current output of the aforementioned 24 VAC power output terminals is 300 mA (or 320 mA for max. 2 minutes).

Consequently, if only those two 24 VAC power output terminals used to supply the triacs already have the max. permissible combined current output of 300 mA (or 320 mA for max. 2 minutes), then the current output of the remaining 24 VAC power output terminals must, of course, equal zero.

### Max. Current Output of Power Output Terminals of 24 VAC Controllers

The 24 VAC power output terminals of the 24 VAC RLxx controllers are terminals 5, 6, 35, 39, 43, and 44 plus pin 4 of the controller's RJ45 interface.

The 24 VAC power output terminals of the 24 VAC RSxx controllers are terminals 3, 4, 22, 23, 24, 25, 27, and 31 plus pin 4 of the controller's RJ45 interface.

The max. permissible combined current output of these 24 VAC power output terminals is 300 mA.

## Relay Outputs



### CAUTION

Mixing of different voltages (e.g., 24 V and 230 V) within the relay block is not allowed.

The terminal blocks containing the controller's relay outputs are orange. Relay output types: See Table 3.

**NOTE:** If inductive components are to be connected to the relays and if these relays switch more often than once every two minutes, these components must be prevented from causing harmful interference to radio or television reception (conformance with EN 45014).

### Relay Current Limitations

If the triacs are supplied with current from an external source, then a maximum of two relays may be loaded with a max. of

4 A per relay – even if two triacs are each simultaneously loaded with max. 300 mA.

If the triacs are supplied with current from an internal source, a maximum of two relays may be loaded as follows: a max. load of 4 A for a relay serving a fan and a max. load of 10 A for a relay serving a reheat – even if one triac is simultaneously loaded with 300 mA.

## Triac Outputs

**NOTE:** Recommended fuse (F1): 1.25 A time-lag fuse (IEC). User must consider the correct voltage and max. breaking capacity / interrupting rate (line voltage urgently requires high breaking capacity / interrupting rate).

The terminal blocks containing the controller's triac outputs are orange.

These triac outputs can be configured (using, e.g., the CLROOMUP configuration tool) for a variety of different functions, e.g., for connection to either a floating drive or to a thermal actuator. Once the triac outputs have been configured, the corresponding devices can then be connected to them directly.

**NOTE:** The VC6983 actuator is intended for use at relay outputs, only and must not be used at the controller's triac outputs.

## Triac Current Limitations

The max. allowed current with which the ensemble of a controller's triacs may be loaded is dependent upon whether the outputs are supplied by the controller's internal transformer or by an external current supply).

Specifically, if the triacs are supplied with 24 VAC current by the controller's internal transformer, the ensemble of a controller's triacs may be loaded with 300 mA (or 320 mA for a max. of 2 minutes); when supplied by an external source, this value is doubled.

However, regardless of whether the triacs are supplied internally or externally, a single triac must never be loaded with a current of more than 300 mA (320 mA for max. 2 minutes).

Nevertheless, the ensemble of triacs can be loaded for very short periods of time (on the order of milliseconds) with a current on the order of 2500 mA typically encountered when switching on multiple thermal actuators.

## Universal Inputs

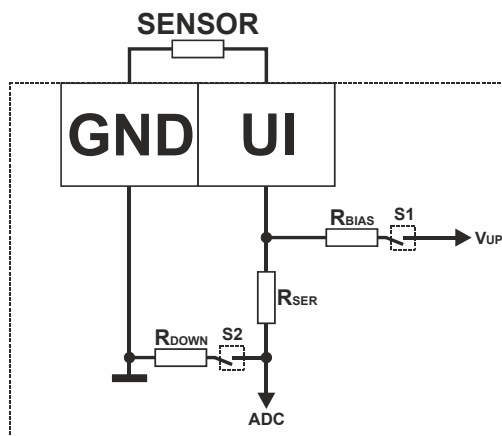
The terminal blocks containing the controller's universal inputs are blue. Universal input types: See Table 4.

The universal inputs are protected against voltages of max. 29 VAC and 30 VDC (due to, e.g., miswiring).



## Bias Resistors

Each universal input is equipped with one bias resistor. See Fig. 22.



**Fig. 22. Schematic of universal inputs and bias resistors**

### LEGEND:

- $V_{UP}$  = 10 V (except for UI1-4 of RL8, which have 24 V).
- $R_{BIAS}$  = Bias resistor (with a resistance of 24.9 k $\Omega$  in the case of NTC10k $\Omega$  and NTC20k $\Omega$  sensor inputs, and 7.5 k $\Omega$  in the case of Pt1000 sensor inputs); can be switched OFF via software by S1 to support 0...10 V inputs without bias current ("high impedance") – except in the case of UI1-4 of RL8, which have a resistance of 11.8 k $\Omega$  and cannot be switched OFF.
- $R_{SER}$  = Series resistor for voltage dividing and filtering (with a resistance of 150 k $\Omega$ ).
- $R_{DOWN}$  = An internal load resistor (with a resistance of 49 k $\Omega$ ); depending upon the given type of connected sensor, the firmware may switch this resistor OFF.

## Analog Outputs

The terminal blocks containing the controller's analog outputs are green. Analog output types: See Table 5.

The analog outputs of the RLx controllers (large housing) are protected against voltages of max. 29 VAC and 30 VDC (due to, e.g., miswiring).

**NOTE:** Connecting 24 VAC to any analog output of the RSx controller (small housing) will damage the hardware.

## Free I/O Option

The limitations – including model-dependent limitations – set forth in Table 2, Table 3, Table 4, Table 5 apply. Further limitations are explained below.

### Free Universal Inputs

#### Max. 5 BACnet Analog Input Objects

Under the free I/O option, a maximum of five of the MERLIN controller's unused UIs are available for use as analog inputs by the plant controller. However, they cannot be used for receiving input from NI1000TK5000 sensors.

#### Max. 5 BACnet Binary Input Objects

Under the free I/O option, a maximum of five of the MERLIN Controller's unused UIs are available for use as binary inputs by the plant controller.

#### Max. 2 BACnet Accumulator Objects

Under the free I/O option, a maximum of two of the MERLIN Controller's unused UIs are available for use as accumulators by the plant controller.

These accumulators can have up to 30 Hz (pulse ON  $\geq$  16 ms; pulse OFF  $\geq$  16 ms; closed: voltage < 1 V; open: voltage > 5 V).

These accumulators can be used, e.g., for energy meters which create pulses when energy is consumed.

## Free Outputs

#### Max. 4 BACnet Analog Output Objects

Under the free I/O option, a maximum of four of the MERLIN Controller's unused outputs (analog or binary outputs) may be used with BACnet Analog Output objects by the plant controller. Possible characteristics are as follows:

- analog output: 0(2)..10 V outputs;
- floating output: triac or relay outputs;
- PWM: triac outputs;
- 1-, 2-, 3-stage output: triac / relay outputs.

#### Max. 4 BACnet Binary Output Objects

Under the free I/O option, a maximum of four of the MERLIN Controller's unused relays and triacs are available for use as binary outputs by the plant controller. However, they can be used only as ON / OFF binary outputs.

### Example:

The customer wants the plant controller to use some of the I/Os of the CLMERL2 not used by the application as free I/Os, and therefore hardwires the free inputs/outputs as follows:

- |                   |                                     |
|-------------------|-------------------------------------|
| UI1, 2:           | used as 0...10V inputs              |
| UI3:              | used as an NTC20k temperature input |
| UI4, 5:           | used as binary inputs               |
| UI6:              | used as a counter                   |
| AO1:              | used as an 0...10V output           |
| AO2:              | used as an 0...10V output           |
| Triac 1, 2:       | used as floating actuator outputs   |
| Triac 3, 4:       | used as floating actuator outputs   |
| Relay 1, 2, 3, 4: | used as binary outputs              |

In the above example, the customer has used the maximum of four analog characteristics.

No further analog characteristic can be assigned; e.g. relays 1, 2 could not be used as multistate outputs.

## WALL MODULES

The CLCM1T,2T,4T,5T,6T111 and CLCMTR40x/TR42x Wall Modules can be used in conjunction with the controller to perform room temperature sensing, setpoint adjustment, fan speed manual override, and occupancy override.

**NOTE:** The CLCMTR42x Wall Module must be version 1.00.3 or higher.

Further, the LED of the CLCM4T,5T,6T111 and the LCD of the CLCMTR42x can be configured to provide information about:

- any override of the controller by, e.g., pressing the "occupancy" button of the wall module or receipt by the controller of a BACnet MS/TP network command (see section "CLCM Configured to Display Info on Overrides" below);
- the controller's effective occupancy mode (see section "CLCM Configured to Display Info on Occupancy" below).

**NOTE:** The intended use of the wall module's buttons must be configured using the CLROOMUP configuration tool.

**Table 13. Supported wall module functions**

	temp. sensor <sup>A)</sup>	setpt. adjustment <sup>A)</sup>	bypass <sup>A)</sup>	fanspeed override <sup>A)</sup>	LED
CLCM1T11N (T7460A1001)	X	--	--	--	--
CLCM2T11N (T7460B1009)	X	X	--	--	--
CLCM4T111 (T7460C1007)	X	X	X	--	X
CLCM5T111 (T7460E1002)	X	X	X	auto-0-1	X
CLCM6T111 (T7460F1000)	X	X	X	auto-0-1-2-3	X

A) Requires one UI supporting NTC.

**NOTE:** The CLMERL8 has ten UIs, only two of which support NTC; this model is thus not suitable for the hardwiring of wall modules requiring three UIs supporting NTC.

See also corresponding Technical Literature listed in Table 14 on pg. 21.

### Configuration of Wall Module LED / LCD

The LED of a CLCM4T,5T,6T111 Wall Module can be configured (using the CLROOMUP configuration tool) to provide information about, e.g., overrides or effective occupancy modes. The LCD of the CLCMTR42x can likewise be configured to display such information. See also ComfortPoint Open Room Contr. – Application Guide (EN2B-0053IE10) for more information.

### CLCM Configured to Display Info on Overrides

The LED of a CLCM4T,5T,6T111 Wall Module connected to the controller can be configured to indicate if an override has been activated because either the wall module's override button has been pressed or the controller has received a BACnet MS/TP network command. Specifically, the following modes are supported:

- NO OVERRIDE:** If the wall module's LED is OFF, then no override is currently in effect.
- OVERRIDE OCCUPANCY:** If the wall module's LED is ON continuously, then the wall module's override button or a BACnet MS/TP network command has placed the controller into the "occupied" or "override" mode (but if the

override button is again pushed or if a cancellation network command is received or if the override time expires, the controller will return to its scheduled occupancy mode, and the wall module's LED will behave accordingly).

- OVERRIDE HOLIDAY:** If the wall module's LED flashes 2 sec OFF and 1 sec ON, then the controller has received a network command and been placed in the "holiday" mode.
- OVERRIDE UNOCCUPIED:** If the wall module's LED flashes once per sec, then the wall module's override button or a network command has placed the controller into the "unoccupied" mode (however, if the override button is again pushed or if a cancellation BACnet MS/TP network command is received, the controller will return to its scheduled occupancy mode, and the wall module's LED will behave accordingly).
- If the wall module's LED flashes twice per sec, then a BACnet MS/TP network command has placed the controller into either the "standby" or the "occupied" mode.

### CLCM Configured to Display Info on Occupancy

The LED of a CLCM4T,5T,6T111 Wall Module connected to the controller can also be configured to indicate the controller's effective occupancy mode. Specifically, the following modes are supported:

- UNOCCUPIED:** If the wall module's LED is OFF, then the controller is in the "unoccupied" mode.
- STANDBY:** If the wall module's LED flashes once per sec, then the controller has received a network command and been placed in the "standby" mode.
- OCCUPIED:** If the wall module's LED is ON, then the controller is in the "occupied" mode.
- BYPASS:** If the wall module's LED is ON continuously, then the controller has received a network command and been placed in the "bypass" mode.
- HOLIDAY:** If the wall module's LED is OFF, then the controller has received a network command and been placed in the "holiday" mode.

### LCD of a TR42x Configured to Display Info on Occupancy

The LCD of a CLCMTR42x connected to the controller can be configured to display various texts and symbols to indicate the effective occupancy mode of the controller. See the following sections "Unoccupied Mode," "Standby Mode," and "Occupied Mode."

Unoccupied Mode

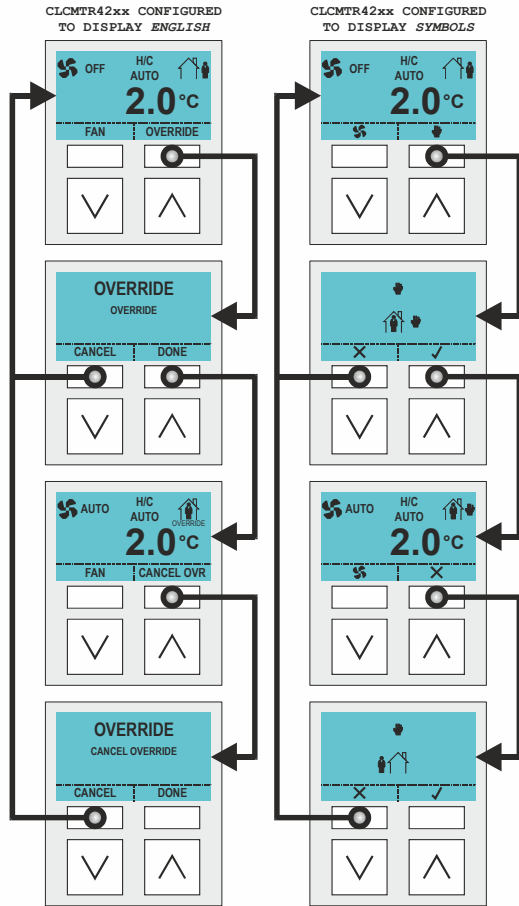


Fig. 23. Example "unoccupied" screens

If is displayed, the controller is in the "unoccupied" mode.

The user can override the "unoccupied" mode by touching the upper right softkey. An intermediate screen will then flash for a few seconds, allowing the user to either cancel (upper left softkey) or confirm (upper right softkey). If the user neither cancels nor confirms, this will be considered a confirmation, and the controller will be placed in the "overridden to bypass" mode. If, on the other hand, the user cancels, the controller will revert to the "unoccupied" mode.

Standby Mode

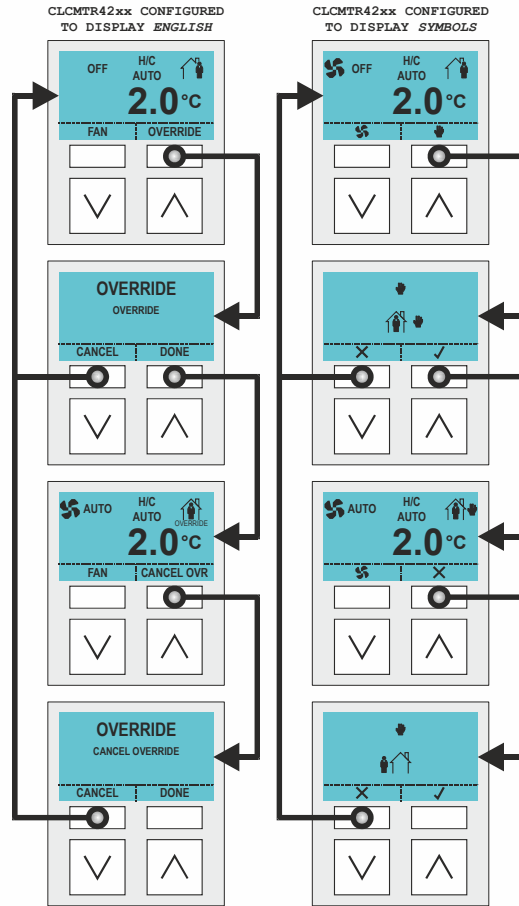


Fig. 24. Example "standby" screens

If is displayed, the controller is in the "standby" mode.

The user can override the "standby" mode by touching the upper right softkey. An intermediate screen will then flash for a few seconds, allowing the user to either cancel (upper left softkey) or confirm (upper right softkey). If the user neither cancels nor confirms, this will be considered a confirmation, and the controller will be placed in the "overridden to bypass" mode. If, on the other hand, the user cancels, the controller will revert to the "standby" mode.

Occupied Mode

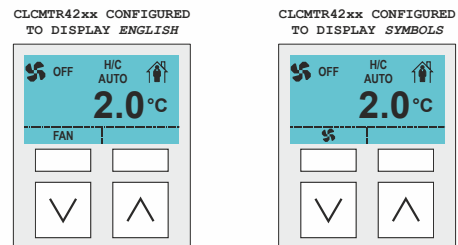


Fig. 25. Example "occupied" screens

If is displayed, the controller is in the "occupied" mode.

### LCD of a TR42x Configured to Display Info on Fan

If OFF is displayed, the fan is switched OFF. Depending upon the given application configuration, the effective control mode for underfloor heating, radiator, ceiling heating, and ceiling cooling can then be switched OFF as well.

### Configuring the TR42x for Heating / Cooling

With the TR42x, the user can select whether he wants to have:

- cooling (C),
- heating (H), or
- cooling plus heating (auto) (H/C AUTO).

By doing so, inadvertent heating or cooling is prevented. Selecting "auto" results in automatic switching between cooling and heating.

To make these selections, the user must enter the expanded menu (see section below).

### Expanded Menu

The user can enter the expanded menu at any time (i.e., in any mode). This is done by touching both upper softkeys simultaneously (see Fig. 26). The "temperature" screen appears first. The user can scroll to further screens ("heating / cooling," "relative humidity," and "CO<sub>2</sub> concentration") using the left (V) or right (Δ) arrow softkey.

**NOTE:** The user can, at any time, exit the expanded menu using the upper left softkey (below the "H/C AUTO" symbol or the word "HOME") or the word "HOME" – or by simply waiting approx. 60 seconds.

In the expanded menu, the current temperature, relative humidity, and CO<sub>2</sub> concentration can be displayed.

The user can change automatic heating / cooling by scrolling (arrow softkeys) to the "heating / cooling" screen and then touching the upper right softkey, (below the "H/C AUTO" symbol or the word "EDIT"). The actual setting will then flash at 1 Hz for approx. 7 seconds, during which time the user can either cancel the given setting (upper left softkey, below the "X" symbol or the word "CANCEL") or confirm it (upper right softkey, below the "✓" symbol or the word "DONE"). If no action is taken within this time, the given setting is automatically confirmed.

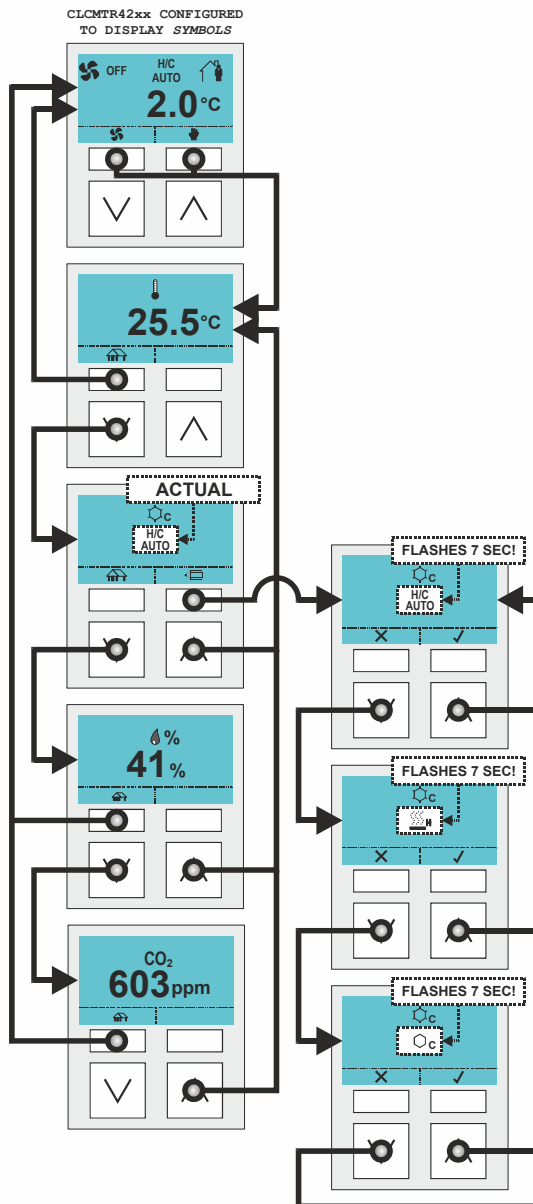


Fig. 26. Accessing the expanded menu

## TROUBLESHOOTING

All units feature a Service Button, Status LED, Power LED, and two additional LEDs (T1 and R1) for commissioning and troubleshooting. See also Table 8 and Table 9 and section "Service Button".

Check if the Status LED's behavior is changed if you switch the power OFF/ON. Please contact Honeywell if this does not solve the problem.

Further, the test function of the CLROOMUP commissioning and configuration tool can also be used to carry out general application and wiring checks. CLROOMUP also features a BACnet Object Browser which can prove very helpful in analyzing the controller's function and communication.

## ACCESSORIES

Terminal Protection Cover; required for wall mounting. Bulk pack, set of ten covers.

- For large controllers, order no.: IRM-RLC
- For small controllers, order no.: IRM-RSC

## APPROVALS, CERTIFICATIONS, ETC.

### Approvals and Certifications

- UL 60730-1, Standard for Automatic Electric Controls for Household and Similar Use, Part 1: General Requirements;
- CAN/CSA-E60730-1:02, Standard for Automatic Electrical Controls for Household and Similar Use, Part 1: General Requirements;
- Complementary listing for UL916, CSA C22.2 No. 205;
- BTL-listed, BACnet AAC profile;
- SASO-approved;
- CE-approved;
- FCC part 15B-compliant: This equipment has been tested and found to comply with the limits for a Class B digital device, pursuant to part 15 of the FCC Rules. These limits are designed to provide reasonable protection against harmful interference in a residential installation. This equipment generates, uses, and can radiate radio-frequency energy and, if not installed and used in accordance with the instructions, may cause harmful interference to radio communications. However, there is no guarantee that interference will not occur in a particular installation. If this equipment does cause harmful interference to radio or television reception, which can be determined by turning the equipment off and on, the user is encouraged to try to correct the interference by one or more of the following measures:
  - Reorient or relocate the receiving antenna.
  - Increase the separation between the equipment and receiver.
  - Connect the equipment into an outlet on a circuit different from that to which the receiver is connected.
  - Consult the dealer or an experienced radio/TV technician for help.

## Classification according to EN 60730-1

EN 60730 sub part:	EN 60730-2-9
Environmental conditions:	For use in home (residential, commercial, and light-industrial) environments
Construction:	independently mounted control, for panel-mounting
Action:	type 1.C
Rated impulse voltage:	2500 V at 230 V; 500 V at 24 V
Pollution degree:	2
Protection against shock:	Class 0 (without terminal covers) Class II (with terminal covers)
Software class:	Class A

## Classification according to EN 60529

(Degree of protection provided by enclosures)

IP20. In the case of controllers mounted outside of a cabinet, before applying power to the device, Terminal Protection Covers (10-pc. bulk packs, order no.: IRM-RLC for large housings and IRM-RSC for small housings) must be mounted so as to provide IP30.

## Ambient Environmental Limits (5...90% r.H., non-condensing)

Operating temperature (floor/ceiling mounting):	0 ... +40 °C
Operating temperature (wall/rail mounting):	0 ... +50 °C
Storage temperature:	-20 ... +70 °C

## RELATED TECHNICAL LITERATURE

Table 14. Related Technical Literature

Title	Product Literature no.
CLMERxx Room Controller – Mount. Instr.	MU1Z-1015GE51
CLMERxx Room Controller – Data Sheet	EN0Z-1015GE51
CLMERxx Room Controller – Inst. & Comm. Instr.	EN1Z-1015GE51
Honeywell CPO IRM Controller PICS	EN0B-0748GE51
CLCM1T,2T,4T,5T,6T – Product Data	EN0Z-0901GE51
CLCM1T,2T,4T,5T,6T – Installation Instructions	MU1Z-0901GE51
CLCMTR40x/TR42x – Specification Data	EN0Z-0990GE51

## APPENDIX: SENSOR CHARACTERISTICS

### Sensor Input Accuracy

The controller's internal sensor inputs support NTC10kΩ and NTC20kΩ sensors. The following table lists the typical minimum accuracies of the hardware and software for these temperature sensors.

**Table 15. Accuracies of internal NTC10kΩ and NTC20kΩ sensor inputs of the Excel Web II**

range	measurement error (excluding sensor characteristics)	
	NTC10kΩ <sup>(1)</sup>	NTC20kΩ
-50 ... -20 °C (-58 ... -4 °F)	≤ 5.0 K	≤ 5.0 K
-20 ... 0 °C (-4 ... +32 °F)	≤ 1.0 K	≤ 1.0 K
0 ... 30 °C (32 ... 86 °F)	≤ 0.5 K	≤ 0.3 K
30 ... 70 °C (86 ... 158 °F)	≤ 0.5 K	≤ 0.5 K
70 ... 100 °C (158 ... 212 °F)	≤ 1.0 K	≤ 1.0 K
100 ... 130 °C (212 ... 266 °F)	--	≤ 3.0 K
130 ... 150 °C (266 ... 302 °F)	--	≤ 5.5 K
150 ... 400 °C (302 ... 752 °F)	--	--

<sup>(1)</sup> NTC10kΩ specified for -30 ... +100 °C, only.

**NOTE:** This is the accuracy of the internal sensor input (hardware + software [linearization]), only. This table does not include the characteristics of the sensors, themselves (see section "Sensor Characteristics" below). If a different sensor or sensor accuracy is required, one may instead use the inputs of, e.g., a connected Panel I/O module.

### Recognition of Sensor Failure of Sensor Inputs

The thresholds at which sensor failures – i.e., sensor breaks (SB) and short-circuits (SC) – are recognized depends upon the given sensor type. In the event of a recognized sensor failure, the sensor inputs assume the safety values configured in CARE. Table 16 lists the measurement ranges and the corresponding thresholds for the recognition of sensor failure for the various different sensor types:

**Table 16. Thresholds for short-circuit (SC) and sensor-break (SB) recognition**

I/O configuration	measurement range	recognition thresholds
2...10 V	2...10 V / 4...20 mA (without pull-up)	SC: < 1.5 V / 3 mA; SB: no recognition
NTC10kΩ	-50 ... +100 °C	SC: < 20 Ω; SB: < -70 °C
NTC20kΩ	-50 ... +150 °C	SC: < 20 Ω; SB: < -70 °C
PT1000	-30 ... + 400 °C	SC: < 775 Ω; SB: < -50 °C
Ni1000TK5000	-70 ... +130 °C	SC: < 850 Ω; SB: < -30 °C

**NOTE:** In the case of temperatures lying *outside* the aforementioned ranges, the lowest/highest value *within* the range, instead, will be communicated. Thus a temperature of -51 °C will be communicated as "-50 °C."

### Sensor Characteristics

The characteristics (resistance in relation to temperature) of the sensors and the resultant voltage are listed on the following pages. The stated values do not include failures due to: sensor failures; wiring resistance or wiring failures; misreadings due to a meter connected to measure resistance or voltage at the input.

**NTC 10 kΩ**

Temp. [°C]	Resistance [kΩ]	Terminal voltage [V]
-30	177	7.904
-29	166.35	7.848
-28	156.413	7.790
-27	147.136	7.730
-26	138.47	7.666
-25	130.372	7.601
-24	122.8	7.534
-23	115.718	7.464
-22	109.089	7.392
-21	102.883	7.318
-20	97.073	7.241
-19	91.597	7.161
-18	86.471	7.080
-17	81.667	6.996
-16	77.161	6.910
-15	72.932	6.821
-14	68.962	6.731
-13	65.231	6.639
-12	61.723	6.545
-11	58.424	6.448
-10	55.321	6.351
-9	52.399	6.251
-8	49.648	6.150
-7	47.058	6.047
-6	44.617	5.943
-5	42.317	5.838
-4	40.15	5.732
-3	38.106	5.624
-2	36.18	5.516
-1	34.363	5.408
0	32.65	5.299
1	31.027	5.189
2	29.494	5.079
3	28.047	4.969
4	26.68	4.859
5	25.388	4.750
6	24.166	4.641
7	23.01	4.532
8	21.916	4.423
9	20.88	4.316
10	19.898	4.209
11	18.968	4.103

Temp. [°C]	Resistance [kΩ]	Terminal voltage [V]
12	18.087	3.998
13	17.252	3.894
14	16.46	3.792
15	15.708	3.690
16	14.995	3.591
17	14.319	3.492
18	13.678	3.396
19	13.068	3.300
20	12.49	3.207
21	11.94	3.115
22	11.418	3.025
23	10.921	2.937
24	10.449	2.850
25	10	2.767
26	9.572	2.684
27	9.165	2.603
28	8.777	2.524
29	8.408	2.447
30	8.057	2.372
31	7.722	2.299
32	7.402	2.228
33	7.098	2.159
34	6.808	2.091
35	6.531	2.025
36	6.267	1.962
37	6.015	1.900
38	5.775	1.840
39	5.546	1.781
40	5.327	1.724
41	5.117	1.669
42	4.917	1.616
43	4.726	1.564
44	4.543	1.514
45	4.369	1.465
46	4.202	1.418
47	4.042	1.373
48	3.889	1.329
49	3.743	1.286
50	3.603	1.244
51	3.469	1.204
52	3.34	1.166
53	3.217	1.128

Temp. [°C]	Resistance [kΩ]	Terminal voltage [V]
54	3.099	1.092
55	2.986	1.057
56	2.878	1.023
57	2.774	0.990
58	2.675	0.959
59	2.579	0.928
60	2.488	0.898
61	2.4	0.870
62	2.316	0.842
63	2.235	0.815
64	2.158	0.790
65	2.083	0.765
66	2.011	0.740
67	1.943	0.718
68	1.877	0.695
69	1.813	0.673
70	1.752	0.652
71	1.694	0.632
72	1.637	0.612
73	1.583	0.593
74	1.531	0.575
75	1.481	0.557
76	1.433	0.541
77	1.387	0.524
78	1.342	0.508
79	1.299	0.493
80	1.258	0.478
81	1.218	0.464
82	1.179	0.450
83	1.142	0.436
84	1.107	0.423
85	1.072	0.411
86	1.039	0.399
87	1.007	0.387
88	0.976	0.375
89	0.947	0.365
90	0.918	0.354
91	0.89	0.344
92	0.863	0.334
93	0.838	0.324
94	0.813	0.315
95	0.789	0.306

Temp. [°C]	Resistance [kΩ]	Terminal voltage [V]
96	0.765	0.297
97	0.743	0.289
98	0.721	0.280
99	0.7	0.276
100	0.68	0.265

## NTC 20 kΩ

Temp. [°C]	Resistance [kΩ]	Terminal voltage [V]
-50.0	1659	8.78
-49.0	1541	8.77
-48.0	1432	8.76
-47.0	1331	8.75
-46.0	1239	8.74
-45.0	1153	8.72
-44.0	1073	8.71
-43.0	1000	8.70
-42.0	932	8.69
-41.0	869	8.67
-40.0	811	8.66
-39.0	757	8.64
-38.0	706	8.62
-37.0	660	8.60
-36.0	617	8.58
-35.0	577	8.56
-34.0	539	8.54
-33.0	505	8.52
-32.0	473	8.49
-31.0	443	8.47
-30.0	415	8.44
-29.0	389	8.41
-28.0	364	8.38
-27.0	342	8.35
-26.0	321	8.32
-25.0	301	8.28
-24.0	283	8.25
-23.0	266	8.21
-22.0	250	8.17
-21.0	235	8.13
-20.0	221	8.08
-19.0	208	8.04
-18.0	196	7.99
-17.0	184	7.94
-16.0	174	7.89
-15.0	164	7.83
-14.0	154	7.78
-13.0	146	7.72
-12.0	137	7.66
-11.0	130	7.60
-10.0	122	7.53
-9.0	116	7.46
-8.0	109	7.39
-7.0	103	7.32
-6.0	97.6	7.25
-5.0	92.3	7.17
-4.0	87.3	7.09
-3.0	82.6	7.01
-2.0	78.2	6.93
-1.0	74.1	6.85

Temp. [°C]	Resistance [kΩ]	Terminal voltage [V]
0.0	70.2	6.76
1.0	66.5	6.67
2.0	63.0	6.58
3.0	59.8	6.49
4.0	56.7	6.40
5.0	53.8	6.30
6.0	51.1	6.20
7.0	48.5	6.10
8.0	46.0	6.00
9.0	43.7	5.90
10.0	41.6	5.80
11.0	39.5	5.70
12.0	37.6	5.59
13.0	35.7	5.49
14.0	34.0	5.38
15.0	32.3	5.28
16.0	30.8	5.17
17.0	29.3	5.07
18.0	27.9	4.96
19.0	26.6	4.85
20.0	25.3	4.75
21.0	24.2	4.64
22.0	23.0	4.53
23.0	22.0	4.43
24.0	21.0	4.32
25.0	20.0	4.22
26.0	19.1	4.12
27.0	18.2	4.01
28.0	17.4	3.91
29.0	16.6	3.81
30.0	15.9	3.71
31.0	15.2	3.62
32.0	14.5	3.52
33.0	13.9	3.43
34.0	13.3	3.33
35.0	12.7	3.24
36.0	12.1	3.15
37.0	11.6	3.06
38.0	11.1	2.97
39.0	10.7	2.89
40.0	10.2	2.81
41.0	9.78	2.72
42.0	9.37	2.64
43.0	8.98	2.57
44.0	8.61	2.49
45.0	8.26	2.42
46.0	7.92	2.34
47.0	7.60	2.27
48.0	7.29	2.20
49.0	7.00	2.14

Temp. [°C]	Resistance [kΩ]	Terminal voltage [V]
50.0	6.72	2.07
51.0	6.45	2.01
52.0	6.19	1.94
53.0	5.95	1.88
54.0	5.72	1.82
55.0	5.49	1.77
56.0	5.28	1.71
57.0	5.08	1.66
58.0	4.88	1.61
59.0	4.69	1.56
60.0	4.52	1.51
61.0	4.35	1.46
62.0	4.18	1.41
63.0	4.03	1.37
64.0	3.88	1.32
65.0	3.73	1.28
66.0	3.59	1.24
67.0	3.46	1.20
68.0	3.34	1.16
69.0	3.21	1.13
70.0	3.10	1.09
71.0	2.99	1.06
72.0	2.88	1.02
73.0	2.78	0.991
74.0	2.68	0.960
75.0	2.58	0.929
76.0	2.49	0.900
77.0	2.41	0.872
78.0	2.32	0.844
79.0	2.24	0.818
80.0	2.17	0.792
81.0	2.09	0.767
82.0	2.02	0.744
83.0	1.95	0.720
84.0	1.89	0.698
85.0	1.82	0.676
86.0	1.76	0.655
87.0	1.70	0.635
88.0	1.65	0.616
89.0	1.59	0.597
90.0	1.54	0.578
91.0	1.49	0.561
92.0	1.44	0.544
93.0	1.40	0.527
94.0	1.35	0.511
95.0	1.31	0.496
96.0	1.27	0.481
97.0	1.23	0.466
98.0	1.19	0.452
99.0	1.15	0.439

Temp. [°C]	Resistance [kΩ]	Terminal voltage [V]
100.0	1.11	0.425
101.0	1.08	0.413
102.0	1.05	0.401
103.0	1.01	0.389
104.0	0.98	0.378
105.0	0.95	0.367
106.0	0.92	0.356
107.0	0.90	0.346
108.0	0.87	0.336
109.0	0.84	0.326
110.0	0.82	0.317
111.0	0.79	0.308
112.0	0.77	0.299
113.0	0.75	0.290
114.0	0.73	0.282
115.0	0.70	0.274
116.0	0.68	0.266
117.0	0.66	0.259
118.0	0.64	0.252
119.0	0.63	0.245
120.0	0.61	0.238
121.0	0.59	0.231
122.0	0.57	0.225
123.0	0.56	0.219
124.0	0.54	0.213
125.0	0.53	0.207
126.0	0.51	0.201
127.0	0.50	0.196
128.0	0.49	0.191
129.0	0.47	0.186
130.0	0.46	0.181
131.0	0.45	0.176
132.0	0.43	0.171
133.0	0.42	0.167
134.0	0.41	0.162
135.0	0.40	0.158
136.0	0.39	0.154
137.0	0.38	0.150
138.0	0.37	0.146
139.0	0.36	0.142
140.0	0.35	0.139
141.0	0.34	0.135
142.0	0.33	0.132
143.0	0.32	0.128
144.0	0.32	0.125
145.0	0.31	0.122
146.0	0.30	0.119
147.0	0.29	0.116
148.0	0.29	0.113
149.0	0.28	0.110
150.0	0.27	0.107



PT 1000

Temp. [°C]	Resistance [Ω]	Terminal voltage [V]
-50.0	803	0.312
-49.0	807	0.314
-48.0	811	0.315
-47.0	815	0.317
-46.0	819	0.318
-45.0	823	0.320
-44.0	827	0.321
-43.0	831	0.323
-42.0	835	0.324
-41.0	839	0.326
-40.0	843	0.327
-39.0	847	0.329
-38.0	851	0.330
-37.0	855	0.332
-36.0	859	0.333
-35.0	862	0.335
-34.0	866	0.336
-33.0	870	0.338
-32.0	874	0.339
-31.0	878	0.341
-30.0	882	0.342
-29.0	886	0.344
-28.0	890	0.345
-27.0	894	0.347
-26.0	898	0.348
-25.0	902	0.350
-24.0	906	0.351
-23.0	910	0.353
-22.0	914	0.354
-21.0	918	0.356
-20.0	922	0.357
-19.0	926	0.359
-18.0	929	0.360
-17.0	933	0.361
-16.0	937	0.363
-15.0	941	0.364
-14.0	945	0.366
-13.0	949	0.367
-12.0	953	0.369
-11.0	957	0.370
-10.0	961	0.372
-9.0	965	0.373
-8.0	969	0.375
-7.0	973	0.376
-6.0	977	0.378
-5.0	980	0.379
-4.0	984	0.380
-3.0	988	0.382
-2.0	992	0.383
-1.0	996	0.385
0.0	1000	0.386
1.0	1004	0.388
2.0	1008	0.389
3.0	1012	0.391
4.0	1016	0.392
5.0	1020	0.394
6.0	1023	0.395
7.0	1027	0.396
8.0	1031	0.398
9.0	1035	0.399

Temp. [°C]	Resistance [Ω]	Terminal voltage [V]
10.0	1039	0.401
11.0	1043	0.402
12.0	1047	0.404
13.0	1051	0.405
14.0	1055	0.406
15.0	1058	0.408
16.0	1062	0.409
17.0	1066	0.411
18.0	1070	0.412
19.0	1074	0.413
20.0	1078	0.415
21.0	1082	0.416
22.0	1086	0.418
23.0	1090	0.419
24.0	1093	0.420
25.0	1097	0.422
26.0	1101	0.423
27.0	1105	0.425
28.0	1109	0.426
29.0	1113	0.428
30.0	1117	0.429
31.0	1121	0.431
32.0	1124	0.432
33.0	1128	0.433
34.0	1132	0.435
35.0	1136	0.436
36.0	1140	0.438
37.0	1144	0.439
38.0	1148	0.441
39.0	1152	0.442
40.0	1155	0.443
41.0	1159	0.445
42.0	1163	0.446
43.0	1167	0.448
44.0	1171	0.449
45.0	1175	0.451
46.0	1179	0.452
47.0	1182	0.453
48.0	1186	0.455
49.0	1190	0.456
50.0	1194	0.458
51.0	1198	0.459
52.0	1202	0.461
53.0	1205	0.462
54.0	1209	0.463
55.0	1213	0.465
56.0	1217	0.466
57.0	1221	0.467
58.0	1225	0.469
59.0	1229	0.470
60.0	1232	0.471
61.0	1236	0.473
62.0	1240	0.474
63.0	1244	0.476
64.0	1248	0.477
65.0	1252	0.479
66.0	1255	0.480
67.0	1259	0.481
68.0	1263	0.483
69.0	1267	0.484

Temp. [°C]	Resistance [Ω]	Terminal voltage [V]
70.0	1271	0.486
71.0	1275	0.487
72.0	1278	0.488
73.0	1282	0.490
74.0	1286	0.491
75.0	1290	0.493
76.0	1294	0.494
77.0	1297	0.495
78.0	1301	0.497
79.0	1305	0.498
80.0	1309	0.499
81.0	1313	0.501
82.0	1317	0.502
83.0	1320	0.503
84.0	1324	0.505
85.0	1328	0.506
86.0	1332	0.508
87.0	1336	0.509
88.0	1339	0.510
89.0	1343	0.512
90.0	1347	0.513
91.0	1351	0.515
92.0	1355	0.516
93.0	1358	0.517
94.0	1362	0.519
95.0	1366	0.520
96.0	1370	0.522
97.0	1374	0.523
98.0	1377	0.524
99.0	1381	0.525
100.0	1385	0.527
101.0	1389	0.528
102.0	1393	0.530
103.0	1396	0.531
104.0	1400	0.532
105.0	1404	0.534
106.0	1408	0.535
107.0	1412	0.537
108.0	1415	0.538
109.0	1419	0.539
110.0	1423	0.541
111.0	1427	0.542
112.0	1430	0.543
113.0	1434	0.545
114.0	1438	0.546
115.0	1442	0.547
116.0	1446	0.549
117.0	1449	0.550
118.0	1453	0.551
119.0	1457	0.553
120.0	1461	0.554
121.0	1464	0.555
122.0	1468	0.557
123.0	1472	0.558
124.0	1476	0.560
125.0	1479	0.561
126.0	1483	0.562
127.0	1487	0.564
128.0	1491	0.565
129.0	1494	0.566

Temp. [°C]	Resistance [Ω]	Terminal voltage [V]
130.0	1498	0.567
131.0	1502	0.569
132.0	1506	0.570
133.0	1510	0.572
134.0	1513	0.573
135.0	1517	0.574
136.0	1521	0.576
137.0	1525	0.577
138.0	1528	0.578
139.0	1532	0.580
140.0	1536	0.581
141.0	1539	0.582
142.0	1543	0.584
143.0	1547	0.585
144.0	1551	0.586
145.0	1554	0.587
146.0	1558	0.589
147.0	1562	0.590
148.0	1566	0.592
149.0	1569	0.593
150.0	1573	0.594
151.0	1577	0.596
152.0	1581	0.597
153.0	1584	0.598
154.0	1588	0.600
155.0	1592	0.601
156.0	1596	0.602
157.0	1599	0.603
158.0	1603	0.605
159.0	1607	0.606
160.0	1610	0.607
161.0	1614	0.609
162.0	1618	0.610
163.0	1622	0.612
164.0	1625	0.613
165.0	1629	0.614
166.0	1633	0.615
167.0	1636	0.617
168.0	1640	0.618
169.0	1644	0.619
170.0	1648	0.621
171.0	1651	0.622
172.0	1655	0.623
173.0	1659	0.625
174.0	1662	0.626
175.0	1666	0.627
176.0	1670	0.629
177.0	1674	0.630
178.0	1677	0.631
179.0	1681	0.632
180.0	1685	0.634
181.0	1688	0.635
182.0	1692	0.636
183.0	1696	0.638
184.0	1699	0.639
185.0	1703	0.640
186.0	1707	0.642
187.0	1711	0.643
188.0	1714	0.644
189.0	1718	0.645

Temp. [°C]	Resistance [Ω]	Terminal voltage [V]
190.0	1722	0.647
191.0	1725	0.648
192.0	1729	0.649
193.0	1733	0.651
194.0	1736	0.652
195.0	1740	0.653
196.0	1744	0.655
197.0	1747	0.656
198.0	1751	0.657
199.0	1755	0.658
200.0	1758	0.659
201.0	1762	0.661
202.0	1766	0.662
203.0	1769	0.663
204.0	1773	0.665
205.0	1777	0.666
206.0	1780	0.667
207.0	1784	0.669
208.0	1788	0.670
209.0	1791	0.671
210.0	1795	0.672
211.0	1799	0.674
212.0	1802	0.675
213.0	1806	0.676
214.0	1810	0.678
215.0	1813	0.679
216.0	1817	0.680
217.0	1821	0.681
218.0	1824	0.683
219.0	1828	0.684
220.0	1832	0.685
221.0	1835	0.686
222.0	1839	0.688
223.0	1843	0.689
224.0	1846	0.690
225.0	1850	0.692
226.0	1854	0.693
227.0	1857	0.694
228.0	1861	0.695
229.0	1865	0.697
230.0	1868	0.698
231.0	1872	0.699
232.0	1875	0.700
233.0	1879	0.702
234.0	1883	0.703
235.0	1886	0.704
236.0	1890	0.705
237.0	1894	0.707
238.0	1897	0.708
239.0	1901	0.709
240.0	1905	0.711
241.0	1908	0.712
242.0	1912	0.713
243.0	1915	0.714
244.0	1919	0.716
245.0	1923	0.717
246.0	1926	0.718
247.0	1930	0.719
248.0	1934	0.721
249.0	1937	0.722

Temp. [°C]	Resistance [Ω]	Terminal voltage [V]
250.0	1941	0.723
251.0	1944	0.724
252.0	1948	0.726
253.0	1952	0.727
254.0	1955	0.728
255.0	1959	0.729
256.0	1962	0.730
257.0	1966	0.732
258.0	1970	0.733
259.0	1973	0.734
260.0	1977	0.736
261.0	1980	0.737
262.0	1984	0.738
263.0	1988	0.739
264.0	1991	0.740
265.0	1995	0.742
266.0	1998	0.743
267.0	2002	0.744
268.0	2006	0.746
269.0	2009	0.747
270.0	2013	0.748
271.0	2016	0.749
272.0	2020	0.750
273.0	2024	0.752
274.0	2027	0.753
275.0	2031	0.754
276.0	2034	0.755
277.0	2038	0.757
278.0	2042	0.758
279.0	2045	0.759
280.0	2049	0.760
281.0	2052	0.761
282.0	2056	0.763
283.0	2060	0.764
284.0	2063	0.765
285.0	2067	0.766
286.0	2070	0.768
287.0	2074	0.769
288.0	2077	0.770
289.0	2081	0.771
290.0	2085	0.773
291.0	2088	0.774
292.0	2092	0.775
293.0	2095	0.776
294.0	2099	0.777
295.0	2102	0.778
296.0	2106	0.780
297.0	2110	0.781
298.0	2113	0.782
299.0	2117	0.784
300.0	2120	0.785
301.0	2124	0.786
302.0	2127	0.787
303.0	2131	0.788
304.0	2134	0.789
305.0	2138	0.791
306.0	2142	0.792
307.0	2145	0.793
308.0	2149	0.794
309.0	2152	0.796

Temp. [°C]	Resistance [Ω]	Terminal voltage [V]
310.0	2156	0.797
311.0	2159	0.798
312.0	2163	0.799
313.0	2166	0.800
314.0	2170	0.802
315.0	2173	0.803
316.0	2177	0.804
317.0	2181	0.805
318.0	2184	0.806
319.0	2188	0.808
320.0	2191	0.809
321.0	2195	0.810
322.0	2198	0.811
323.0	2202	0.812
324.0	2205	0.814
325.0	2209	0.815
326.0	2212	0.816
327.0	2216	0.817
328.0	2219	0.818
329.0	2223	0.820
330.0	2226	0.821
331.0	2230	0.822
332.0	2234	0.823
333.0	2237	0.824
334.0	2241	0.826
335.0	2244	0.827
336.0	2248	0.828
337.0	2251	0.829
338.0	2255	0.830
339.0	2258	0.831
340.0	2262	0.833
341.0	2265	0.834
342.0	2269	0.835
343.0	2272	0.836
344.0	2276	0.838
345.0	2279	0.839
346.0	2283	0.840
347.0	2286	0.841
348.0	2290	0.842
349.0	2293	0.843
350.0	2297	0.845
351.0	2300	0.846
352.0	2304	0.847
353.0	2307	0.848
354.0	2311	0.849
355.0	2314	0.850
356.0	2318	0.852
357.0	2321	0.853
358.0	2325	0.854
359.0	2328	0.855
360.0	2332	0.856
361.0	2335	0.857
362.0	2339	0.859
363.0	2342	0.860
364.0	2346	0.861
365.0	2349	0.862
366.0	2353	0.863
367.0	2356	0.864
368.0	2360	0.866
369.0	2363	0.867

Temp. [°C]	Resistance [Ω]	Terminal voltage [V]
370.0	2367	0.868
371.0	2370	0.869
372.0	2373	0.870
373.0	2377	0.871
374.0	2380	0.872
375.0	2384	0.874
376.0	2387	0.875
377.0	2391	0.876
378.0	2394	0.877
379.0	2398	0.878
380.0	2401	0.879
381.0	2405	0.881
382.0	2408	0.882
383.0	2412	0.883
384.0	2415	0.884
385.0	2419	0.885
386.0	2422	0.886
387.0	2426	0.888
388.0	2429	0.889
389.0	2432	0.890
390.0	2436	0.891
391.0	2439	0.892
392.0	2443	0.893
393.0	2446	0.894
394.0	2450	0.896
395.0	2453	0.897
396.0	2457	0.898
397.0	2460	0.899
398.0	2463	0.900
399.0	2467	0.901
400.0	2470	0.902

NI1000TK5000

Temp. [°C]	Resistance [Ω]	Terminal voltage [V]
-30	871.7	0.338
-29	875.8	0.340
-28	880	0.341
-27	884.1	0.343
-26	888.3	0.344
-25	892.5	0.346
-24	896.7	0.348
-23	900.8	0.349
-22	905.1	0.351
-21	909.3	0.352
-20	913.5	0.354
-19	917.7	0.355
-18	922	0.357
-17	926.2	0.359
-16	930.5	0.360
-15	934.7	0.362
-14	939	0.363
-13	943.3	0.365
-12	947.6	0.367
-11	951.9	0.368
-10	956.2	0.370
-9	960.6	0.371
-8	964.9	0.373
-7	969.3	0.375
-6	973.6	0.376
-5	978	0.378
-4	982.4	0.380
-3	986.7	0.381
-2	991.2	0.383
-1	995.6	0.384
0	1000	0.386
1	1004.4	0.388
2	1008.9	0.389
3	1013.3	0.391
4	1017.8	0.393
5	1022.3	0.394
6	1026.7	0.396
7	1031.2	0.398
8	1035.8	0.399
9	1040.3	0.401
10	1044.8	0.403
11	1049.3	0.404
12	1053.9	0.406
13	1058.4	0.408
14	1063	0.409
15	1067.6	0.411
16	1072.2	0.413
17	1076.8	0.415

Temp. [°C]	Resistance [Ω]	Terminal voltage [V]
18	1081.4	0.416
19	1086	0.418
20	1090.7	0.420
21	1095.3	0.421
22	1100	0.423
23	1104.6	0.425
24	1109.3	0.427
25	1114	0.428
26	1118.7	0.430
27	1123.4	0.432
28	1128.1	0.433
29	1132.9	0.435
30	1137.6	0.437
31	1142.4	0.439
32	1147.1	0.440
33	1151.9	0.442
34	1156.7	0.444
35	1161.5	0.446
36	1166.3	0.447
37	1171.2	0.449
38	1176	0.451
39	1180.9	0.453
40	1185.7	0.455
41	1190.6	0.456
42	1195.5	0.458
43	1200.4	0.460
44	1205.3	0.462
45	1210.2	0.463
46	1215.1	0.465
47	1220.1	0.467
48	1225	0.469
49	1230	0.471
50	1235	0.473
51	1240	0.474
52	1245	0.476
53	1250	0.478
54	1255	0.480
55	1260.1	0.482
56	1265.1	0.484
57	1270.2	0.485
58	1275.3	0.487
59	1280.3	0.489
60	1285.4	0.491
61	1290.6	0.493
62	1295.7	0.495
63	1300.8	0.496
64	1306	0.498
65	1311.1	0.500

Temp. [°C]	Resistance [Ω]	Terminal voltage [V]
66	1316.3	0.502
67	1321.5	0.504
68	1326.7	0.506
69	1331.9	0.508
70	1337.1	0.510
71	1342.4	0.512
72	1347.6	0.513
73	1352.9	0.515
74	1358.2	0.517
75	1363.5	0.519
76	1368.8	0.521
77	1374.1	0.523
78	1379.4	0.525
79	1384.8	0.527
80	1390.1	0.529
81	1395.5	0.531
82	1400.9	0.533
83	1406.3	0.535
84	1411.7	0.537
85	1417.1	0.538
86	1422.5	0.540
87	1428	0.542
88	1433.4	0.544
89	1438.9	0.546
90	1444.4	0.548
91	1449.9	0.550
92	1455.4	0.552
93	1460.9	0.554
94	1466.5	0.556
95	1472	0.558
96	1477.6	0.560
97	1483.2	0.562
98	1488.8	0.564
99	1494.4	0.566
100	1500	0.568
101	1505.6	0.570
102	1511.3	0.572
103	1517	0.574
104	1522.6	0.576
105	1528.3	0.578
106	1534	0.580
107	1539.7	0.582
108	1545.5	0.584
109	1551.2	0.586
110	1557	0.589
111	1562.8	0.591
112	1568.5	0.593
113	1574.4	0.595

Temp. [°C]	Resistance [Ω]	Terminal voltage [V]
114	1580.2	0.597
115	1586	0.599
116	1591.8	0.601
117	1597.7	0.603
118	1603.6	0.605
119	1609.5	0.607
120	1615.4	0.609
121	1621.3	0.611
122	1627.2	0.613
123	1633.2	0.616
124	1639.1	0.618
125	1645.1	0.620
126	1651.1	0.622
127	1657.1	0.624
128	1663.1	0.626
129	1669.1	0.628
130	1675.2	0.630

**Trademark Information**

BACnet™ is a trademark of ASHRAE Inc.

LON, LONWORKS, and Neuron are trademarks of Echelon Corporation registered in the United States and other countries.

Manufactured for and on behalf of the Connected Building Division of Honeywell Products and Solutions SARL, Z.A. La Pièce, 16, 1180 Rolle, Switzerland by its Authorized Representative:

CentraLine  
Honeywell GmbH  
Böblinger Strasse 17  
71101 Schönaich, Germany  
Phone +49 (0) 7031 637 845  
Fax +49 (0) 7031 637 740  
[info@centraline.com](mailto:info@centraline.com)  
[www.centraline.com](http://www.centraline.com)

Subject to change without notice  
EN1Z-1015GE51 R0119

