

### INSTALLATION AND COMMISSIONING INSTRUCTIONS

#### CONTENTS

<b>Safety Information.....</b>	<b>2</b>	Updating Software .....	29
General Safety Information .....	2	<b>Connecting to External Systems or Interfaces .....</b>	<b>30</b>
Safety Information as per EN60730-1.....	2	Connecting via LONWORKS Bus .....	30
<b>System Overview .....</b>	<b>3</b>	Connecting via C-Bus .....	31
System Architecture .....	3	Connecting HMI's or Laptops .....	31
I/O Modules .....	4	Connecting Modems .....	31
Interfaces and Bus Connections .....	7	<b>Description of the CLLIONLC01.....</b>	<b>32</b>
Technical Data.....	7	Overview .....	32
<b>Planning .....</b>	<b>8</b>	Features .....	33
Overview.....	8	<b>Description of the I/O Modules .....</b>	<b>38</b>
Transformer Selection .....	8	Common Features .....	38
Fusing Specifications .....	9	<b>Troubleshooting .....</b>	<b>39</b>
System Protective Earth Grounding.....	9	Testing Wiring Connections .....	39
Lightning Protection.....	9	Troubleshooting on the CLLIONLC01 Controller .....	39
Panel Bus Topologies .....	9	Appendix 1: System Protective Earth Grounding .....	43
LONWORKS Bus Topologies.....	10	LION Systems and SELV .....	43
C-Bus Topologies .....	10	LION Systems and Standard EN60204-1 .....	43
Accessories .....	10	Earth Grounding of EN60204-1 Applicable Systems .....	43
Cable Specifications.....	11	<b>Appendix 2: Remote Communications .....</b>	<b>45</b>
Dimensions .....	14	Approved Modems .....	45
<b>Mounting/Dismounting Modules .....</b>	<b>16</b>	Modem or ISDN Terminal Adapter Connection.....	45
Mounting/Dismounting Controller/Sockets.....	16	Modem Requirements.....	45
Mounting/Dismounting Electronic Modules.....	18	Troubleshooting .....	45
Mounting/Dismounting Manual Disconnect Modules.....	19	<b>Appendix 3: Sensor Characteristics .....</b>	<b>46</b>
Mounting/Dismounting Auxiliary Terminal Packages .....	20	BALCO 500 .....	46
Mounting/Dismounting Cross Connectors .....	21	NTC 20 kΩ .....	47
Mounting/Dismounting Swivel Label Holders .....	21	PT 1000.....	48
<b>Wiring and Setting Up the System .....</b>	<b>22</b>	NI1000TK5000 .....	50
General Safety Considerations .....	22	NTC 10 kΩ .....	51
Wiring Push-in Terminals .....	22	PT 3000.....	52
Connecting Power Supply .....	23	<b>Trademark Information</b>	
Connecting Single Bus Controller Systems .....	24	Echelon, LON, LONMARK, LONTALK, LONWORKS, Neuron, are	
Connecting Panel Bus and LONWORKS Bus Mixed		trademarks of Echelon Corporation registered in the United	
Controller Systems .....	25	States and other countries.	
Setting Address of Panel Bus I/O Modules.....	27		
Setting I/O Bus Switch.....	27		
Connecting Field Devices .....	28		
Commissioning I/O Modules .....	29		

# Safety Information

## General Safety Information

- ▶ When performing any work (installation, mounting, start-up), all instructions given by the manufacturer and in particular the safety instructions provided in these Installation and Commissioning Instructions are to be observed.
- ▶ The LION System (including the CLLIONLC01, I/O modules, manual disconnect modules, and the auxiliary terminal packages) may be installed and mounted only by authorized and trained personnel.
- ▶ Rules regarding electrostatic discharge should be followed.
- ▶ If the LION System is modified in any way, except by the manufacturer, all warranties concerning operation and safety are invalidated.
- ▶ Make sure that the local standards and regulations are observed at all times. Examples of such regulations are VDE 0800 and VDE 0100 or EN 60204-1 for earth grounding.
- ▶ Use only accessory equipment which comes from or has been approved by Centraline.
- ▶ It is recommended that devices are to be kept at room temperature for at least 24 hours before applying power. This is to allow any condensation resulting from low shipping/storage temperatures to evaporate.
- ▶ The LION System must be installed in such a manner (e.g., in a lockable cabinet) as to ensure that uncertified persons have no access to the terminals.
- ▶ Investigated according to United States Standard UL916 (USL-listed).
- ▶ Investigated according to Canadian National Standard(s) C22.2 (CNL-listed).

## Safety Information as per EN60730-1

### Purpose

The LION System is an incorporated electronic control system for cabinet mounting.

It is used for the purpose of building HVAC control and is suitable for use only in non-safety controls for installation on or in appliances.

<b>Pollution degree</b>	Pollution Degree 2, suitable for use in residential controls, commercial controls, in a clean environment.
<b>Overvoltage category</b>	Category II for mains-powered (16A) controls Category I for 24 V powered controls
<b>Rated impulse voltage</b>	2500 VAC
<b>Automatic action</b>	Type 1.C (micro-interruption for the relay outputs)
<b>Software class</b>	Class A
<b>Ball-pressure test temperature</b>	75 °C for all housing and plastic parts 125 °C in the case of devices applied with voltage-carrying parts and connectors
<b>Electromagnetic interference</b>	Tested at 230 VAC, with the modules in normal condition.
<b>System transformer</b>	Europe: safety isolating transformers according to IEC61558-2-6 U.S.A. and Canada: NEC Class-2 transformers

Table 1 System data as per EN60730-1

# System Overview

## System Architecture

A LION System consists of the CLLIONLC01 Controller and various I/O modules. The CLLIONLC01 Controller provides interface connections, which allow connection to external systems. Auxiliary parts enable special features.

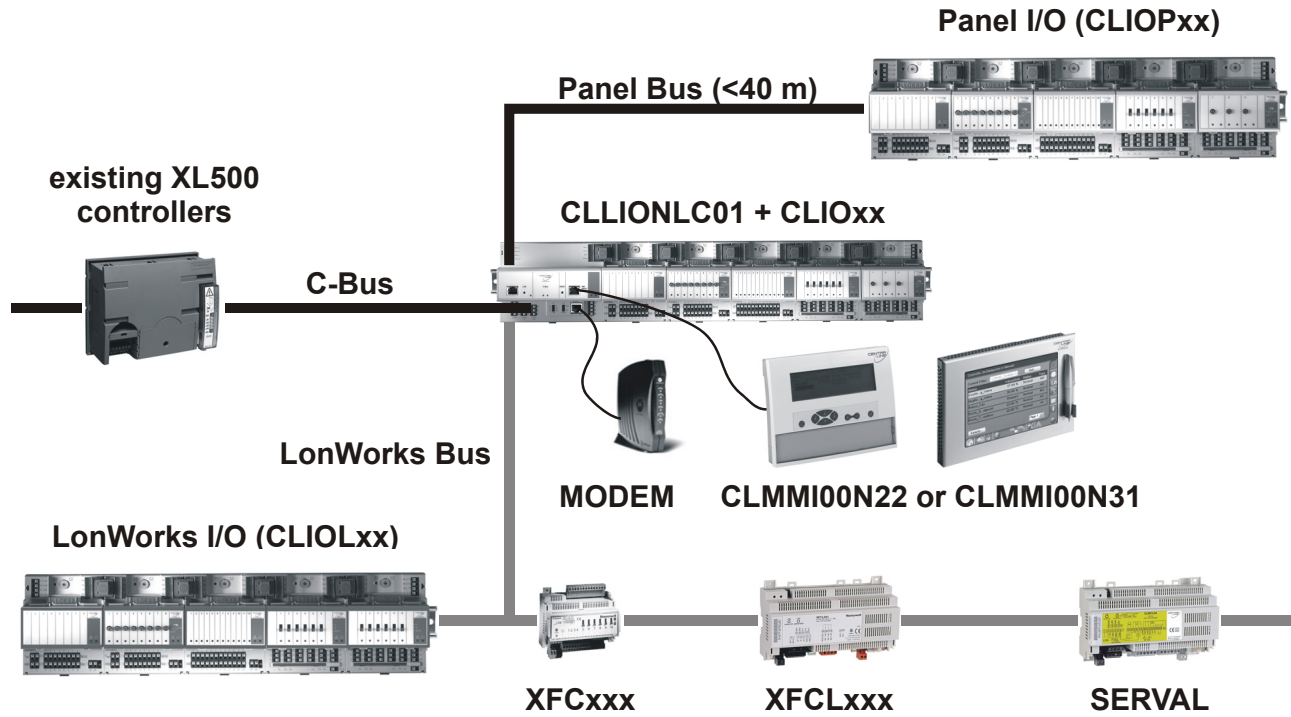

Fig. 1 LION System architecture

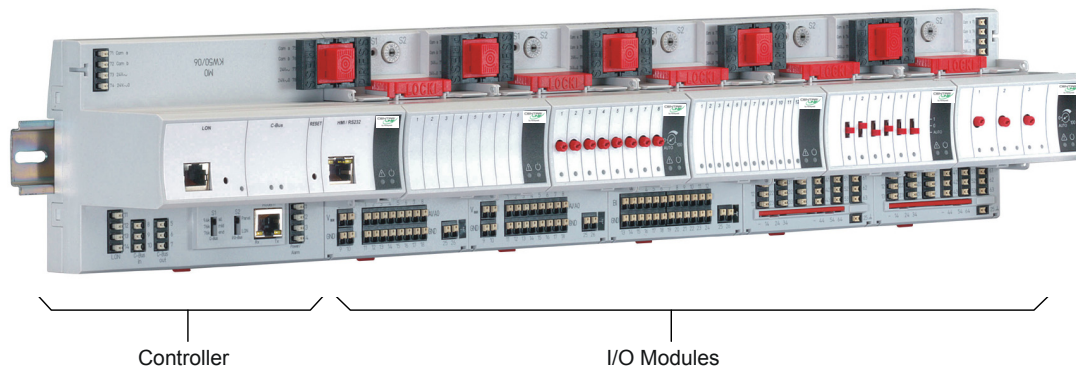

Fig. 2 CLLIONLC01 Controller and I/O modules

## I/O Modules

### Pluggable I/O Modules

There are 2 variants of pluggable I/O modules (consisting of a terminal socket and a removable electronic module):

- Panel Bus I/O modules with communication via Panel Bus (light gray housings)  
Modules are automatically commissioned (with firmware download) by the CLLIONLC01 Controller
- LONWORKS Bus I/O modules (dark gray housings) with communication via LONWORKS (FTT10-A, link power compatible) for easy integration and use with 3<sup>rd</sup>-party controllers

### Mixed I/O Module

Besides the *pluggable* I/O modules, there are also *mixed* Panel Bus I/O modules. Specifically: the CLIOP830A and CLIOP831A are mixed Panel Bus I/O modules featuring an integrated terminal socket and a variety of inputs and outputs.

- The CLIOP830A has a light-gray housing.
- The CLIOP831A has a black housing.

Their firmware is automatically updated and configured by the controller, and the controller automatically configures the mixed Panel Bus I/O modules as needed by the application.

### Terminal Sockets

Pluggable I/O modules are mounted on the appropriate terminal sockets. Pluggable Panel Bus I/O modules and pluggable LONWORKS Bus I/O modules use the same terminal sockets. The terminal sockets are available with push-in terminals (XS821-22, XS823, and XS824-25) or with screw-type terminals (XSU821-22, XSU823, and XSU824-25). The mixed Panel Bus I/O modules (i.e. the CLIOP830A with push-in terminals, and the CLIOP831A with screw-type terminals) feature an integrated terminal socket.

### Color Coding

To distinguish modules and components, the following color coding is used:

Color	Part
Red	All user-accessible adjustable mechanical parts (i.e., bridge connectors and locking mechanism) and operating controls (manual overrides, etc.)
Light-gray	Panel Bus I/O modules (exc. CLIOP831A)
Black	CLIOP831A mixed Panel Bus I/O module
Dark-gray	LONWORKS Bus I/O modules

Table 2 Color coding of LION Modules

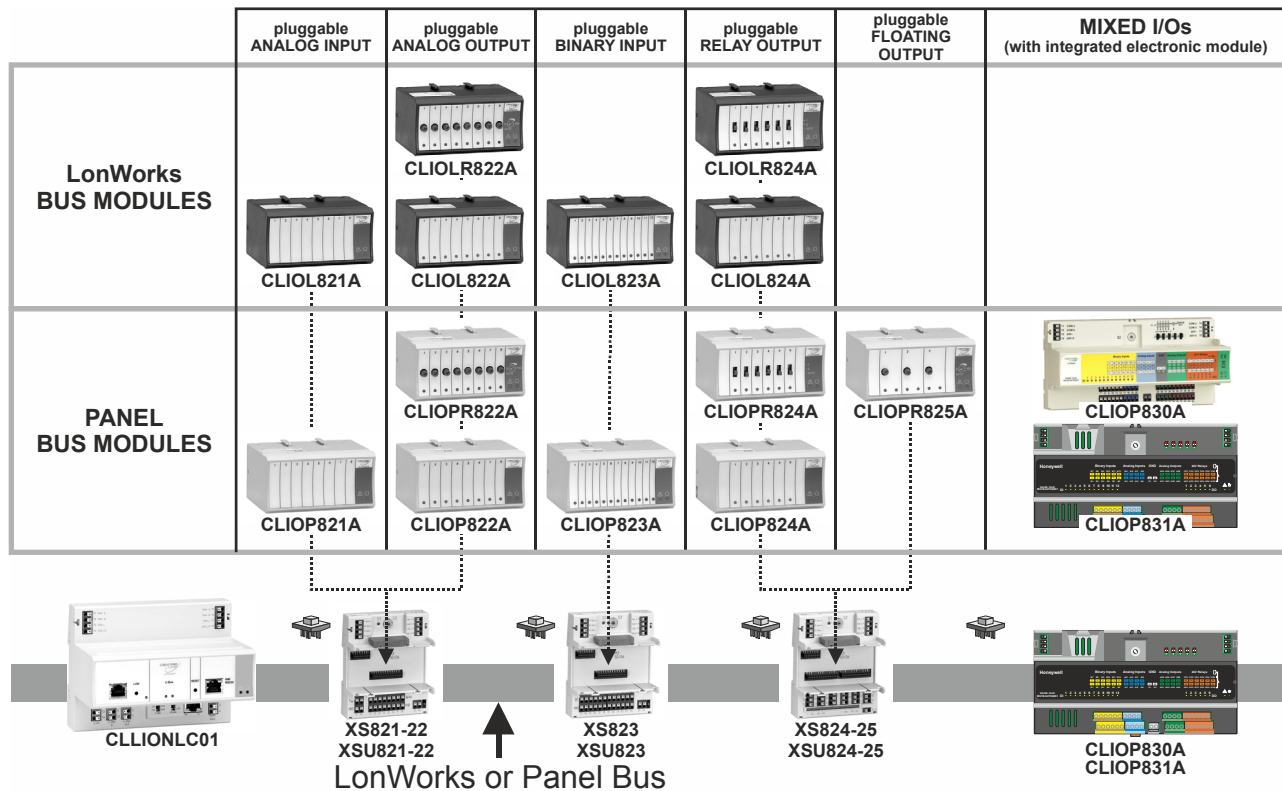

Fig. 3 Overview of I/O modules and terminal sockets

**I/O Module Overview**

Panel Bus module	LONWORKS Bus module	Description	Inputs	Outputs	Manual controls	LEDs <sup>1)</sup>
CLIOP821A	CLIOL821A	Analog input module	8	–	–	–
CLIOP822A	CLIOL822A	Analog output module	–	8	–	8 status LEDs
CLIOPR822A	CLIOLR822A	Analog output module	–	8	8 Manual overrides	8 status LEDs
CLIOP823A	CLIOL823A	Binary input module	12	–	–	12 status LEDs
CLIOP824A	CLIOL824A	Relay output module	–	6 <sup>2)</sup>	–	6 status LEDs
CLIOPR824A	CLIOLR824A	Relay output module	–	6 <sup>2)</sup>	6 Manual overrides	6 status LEDs
CLIOPR825A	–	Floating output module	–	3	3 Manual overrides	3 pairs of status LEDs
CLIOP830A	--	Mixed I/O module	20	14	--	18 status LEDs
CLIOP831A	--	Mixed I/O module	20	14	--	18 status LEDs

<sup>1)</sup> In addition to the power LED and service LED

<sup>2)</sup> Changeover outputs

Table 3 Overview of I/O modules

**Manual Overrides as per EN ISO 16484-2:2004**

The manual override switches and potentiometers of the output modules (...R822A, ...R824A, and CLIOPR825A) support direct operation as per EN ISO 16484-2:2004, section 5.4.3 "Local Priority Override/Indicating Units."

Specifically, the positions of the manual override switches and potentiometers directly control the outputs – independently of the LION Controller and HMI. When a manual override switch or potentiometer is not in its default position ("auto"), the corresponding output LED will blink continuously, and the output module will send a feedback signal with the status "manual override" and the given override position to the LION Controller (which will then also store this information in its alarm memory).

**NOTE:** When updating the firmware of output modules, their outputs are turned OFF – regardless of the position of their manual override switches and/or potentiometers.

**Corresponding Terminal Sockets**

I/O module CLIOP/CLIOL...	Socket	Scope of delivery
...821	XS821-22 XSU821-22	1 terminal socket, 1 bridge connector 1 swivel label holder
...822		
...823	XS823 XSU823	1 terminal socket, 1 bridge connector 1 swivel label holder
...824	XS824-25 XSU824-25	1 terminal socket, 1 bridge connector 1 swivel label holder
...825		

**NOTE:** In the following, e.g., ...822 is used to summarize all analog output modules (Panel Bus/LONWORKS Bus, with/without manual overrides).

Table 4 Pluggable I/O modules and corresponding terminal sockets

## Auxiliary Parts





Module	Type	Figure	Corresponding I/O modules CLIOP/CLIOL...	Information
Manual disconnect modules	XS812		...821 ...822 ...823	Module allows disconnection of individual I/O signals.
	XS812RO		...824 ...825	Module allows disconnection of individual I/O signals. For 24 V applications only.
Auxiliary terminal package	XS814		All pluggable LION I/O modules	Two groups of 7 terminals connected to each other for redistributing voltage.
	XS830		CLIOP830A, only	Two groups of nine internally-connected push-in terminals, for distributing signals/power.
	XS831			Two groups of four pairs of push-in terminals, for converting 0...20 mA signals into 0...10 Vdc signals, and one push-in ground terminal per group.

Table 5 Auxiliary parts

## Spare Parts

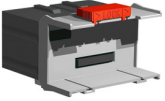
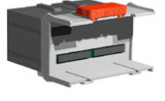

Module	Type	Figure	Corresponding I/O modules CLIOP/CLIOL...	Information
Cross connectors (red)	XS815		...824 ...825	Connects 6 relay commons.
Connector bridge	XS816		All LION I/O modules	Connects CLLIONLC01 and I/O modules.
Swivel label holder	XAL10		All pluggable LION I/O modules	Can be plugged into socket, for attaching label generated by the engineering tool.
Swivel label holder	XAL11		CLIOP830A, only	Can be plugged into module, for attaching label generated by the engineering tool. NOTE: Phased out.

Table 6 Spare parts

## Interfaces and Bus Connections

The LION System can be connected to the following devices and systems:

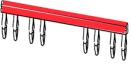
### Panel Bus

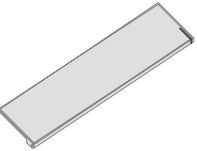
- For communication with up to 16 Panel Bus I/O modules
- Polarity-insensitive

### LONWORKS Bus

- For communication with other LONWORKS Bus devices within the building
- FTT10, link power compatible
- Polarity-insensitive

### C-Bus

- For communication with other controllers, e.g., existing Excel 500 Controllers

### HMI

- For connecting an operator interface (e.g., CLMMI00N22 or CLMMI00N31) or a laptop, e.g., for engineering

### Modem

- For connecting a modem or an ISDN terminal adapter

## Technical Data

### System Data

Operating voltage	24 VAC, ± 20 %, 21 ... 30 VDC
Max. number of C-Bus participants	30
Current requirement	Max. 3.57 A (1 CLLIONLC01 Controller + 16 I/O modules)
Push-in terminals	1.5 mm <sup>2</sup>
Screw-type terminals	1.5 mm <sup>2</sup>
Overvoltage protection	All inputs and outputs are protected against 24 VAC and 40 VDC overvoltage as well as against short-circuiting.
Calculated lifetime of weakest component under typical operating conditions	MTBF ≥ 13.7 years

Table 7 System data

## Standards

Protection class	IP20
Product standard (EMC)	EN 60730-1 EN 60730-2-9
Testing electrical components	IEC68
Certification	CE
System transformer	The system transformer(s) must be safety isolating transformers according to IEC 61558-2-6. In the U.S.A. and Canada, NEC Class 2 transformers must be used.
Low-Voltage Device Safety Assessment	EN 60730-1 EN 60730-2-9

Table 8 Standards

## Operational Environment

Ambient operating temperature	0 ... 50 °C (32 ... 122 °F)
Ambient operating humidity	5 ... 93 % rel. humidity (non condensing)
Ambient storage temperature	-20 ... 70 °C (-4 ... +158 °F)
Ambient storage humidity	5 ... 95 % rel. humidity (non condensing)
Vibration under operation	0.024" double amplitude (2 ... 30 Hz), 0.6 g (30 ... 300 Hz)
Dust, vibration	According to EN60730-1
RFI, EMI	Home environment

Table 9 Operational environment

# Planning

## Overview

### Engineering with CARE

During CARE engineering, the type of I/O modules, terminal assignment and module configuration are defined depending on the application. The same applies to engineering with COACH (which is possible starting with COACH version 2.02).

### Planning

In this step, the following has to be defined, if applicable:

- Power supply
- Fusing
- Earth grounding
- Lightning protection
- Panel Bus wiring
- Design of a LonWorks network
- Design of a C-Bus network
- Useful accessories
- Cable selection

## Transformer Selection

**NOTE:** In Europe, the system transformer(s) must be safety isolating transformers according to IEC61558-2-6.  
In the U.S.A. and Canada, NEC Class-2 transformers must be used.

### Current Requirement

When selecting the appropriate transformer, take into account the number of individual modules, accessories, and field devices in determining the total current requirement.

Devices powered	Current requirement	
	24 VAC	24 VDC
CLLIONLC01 with CLMMI00N22 (backlight ON) and with watchdog load (max. 500 mA)	690 mA	640 mA
CLLIONLC01 with CLMMI00N22 (backlight ON) but without watchdog load	190 mA	140 mA
...821	130 mA	80mA
...822	160 mA	90 mA
...823	180 mA	130 mA
...824	140 mA	90 mA
...825	140 mA	90 mA
CLIOP830A	200 mA	95 mA

Table 10 Current requirement of LION System components depending on power supply

### Connectable Power Supplies

#### CentraLine CRT Series (Europe)

Transformer	Primary side	Secondary side
CRT 2	220/230 VAC	24 VAC, 50 VA, 2 A
CRT 6	220/230 VAC	24 VAC, 150 VA, 6 A
CRT 12	220/230 VAC	24 VAC, 300 VA, 12 A

Table 11 CentraLine CRT series transformers data



**CentralLine 1450 Series (North America)**

- 50/60 Hz
- Insulated accessory outputs
- Built-in fuses
- Line transient /surge protection
- AC convenience outlet
- NEC Class-2

Part number 1450 7287	Primary side	Secondary side
-001	120 VAC	24 VAC, 50 VA
-002	120 VAC	2 x 24 VAC, 40 VA, and 100 VA from separate transformer
-003	120 VAC	24 VAC, 100 VA, and 24 VDC; 600 mA
-004	240/220 VAC	24 VAC, 50 VA
-005	240/220 VAC	2 x 24 VAC, 40 VA, and 100 VA from separate transformer
-006	240/220 VAC	24 VAC, 100 VA, and 24 VDC, 600 mA

Table 12 CentralLine 1450 series transformers data

**Standard Transformers (Europe, North America)**

Standard commercially available transformers used to supply power to LION Systems must fulfill the following specifications:

Output voltage	Impedance	AC current
24.5 VAC to 25.5 VAC	$\leq 1.15 \Omega$	max. 2 A
24.5 VAC to 25.5 VAC	$\leq 0.40 \Omega$	max. 6 A
24.5 VAC to 25.5 VAC	$\leq 0.17 \Omega$	max. 12 A

Table 13 Requirements for standard transformers

**RIN-APU24 Uninterruptable Power Supply**

The RIN-APU24 Uninterruptable Power Supply can be wired to power LION Systems.

See also RIN-APU24 Uninterruptable Power Supply – Mounting Instructions (MU1B-0258GE51) for detailed wiring diagrams.

**Power Supply of Field Devices**

Depending upon the power consumption of the field devices used, it is possible to use either a single transformer to power both the CLLIONLC01 and attached field devices, or it may be necessary to employ an additional transformer. See also section "Field Device Cables" on page 12 and connection examples on page 28.

**Fusing Specifications**

Please observe the following when selecting fusing (F1 / F2) for the CLLIONLC01, I/O modules, and active field devices:

- Use separate fusing for different loads (e.g., for the CLLIONLC01 and I/O modules on one hand versus for active field devices on the other).
- Fuse ratings must always be calculated according to the loads connected. Refer to the load tables appearing in the documentation of your devices (Table 10 provides information on LION device loads).
- Use slow-acting fuses; this is because the CLLIONLC01, the I/O modules, and active field devices have a high in-rush current due to their built-in capacitors (current typically limited by one internal 2 Ohm resistor per device).
- Fuses should be calculated to protect the transformer against overloading and the wiring against short-circuiting. The CLLIONLC01 and the I/O modules are protected by an internal fuse (not user-replaceable) against internal component defects.

For connection examples see description of the I/O modules on page 38 and following.

**System Protective Earth Grounding**

LION Systems comply with SELV (Safety Extra-Low Voltage). Earth grounding is therefore not recommended. However, if compliance with EN60204-1 is required, see Appendix 1.

**Lightning Protection**

Please contact your local CentralLine representative for information on lightning protection.

**Panel Bus Topologies**

- Up to 16 Panel Bus I/O modules can be controlled by a single CLLIONLC01.
- Panel Bus I/O modules must be addressed using the HEX switch on the terminal socket.
- Max. Panel Bus length: 40 meters. Any type of cabling and topology (including star and loop topology) permitted.
- Bus termination unnecessary
- Polarity-insensitive

## LONWORKS Bus Topologies

The LONWORKS Bus is a 78-kilobit serial link that uses transformer isolation so that the bus wiring does not have a polarity. I.e. it is not important which of the two LONWORKS Bus terminals are connected to each wire of the twisted pair.

The LONWORKS Bus does not need to be shielded on the controller module side.

The LONWORKS Bus can be wired in daisy chain, star, loop or any combination thereof as long as the max. wire length requirements are met.

### Configuration

The recommended configuration is a daisy chain with two bus terminations. This layout allows for max. LONWORKS Bus lengths, and its simple structure presents the least number of possible problems, particularly when adding on to an existing bus.

See also "LONWORKS Mechanisms", Product Literature no.: EN0B-0270GE51.

## C-Bus Topologies

Via the C-Bus up to 30 C-Bus devices (e.g., controllers, etc.) can communicate with one another and a PC central. The C-Bus must be connected via the individual controllers (open ring).

**NOTE:** Star connection is not allowed as this might cause uncontrollable line reflections.

Instead of LION Controllers, other C-Bus controllers (e.g., the Excel 500, Excel 100, PANTHER) can also be connected.

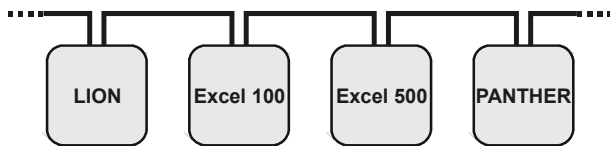

Fig. 4 C-Bus topology Excel 5000

## Accessories

Besides the auxiliary parts of Table 5 on page 6, the following accessories are available.

### Preconfigured Connection Cables

Type	Connecting CLLIONLC01 with	Features
XW882	CLMMI00N22 Operator Interface	5 m, shielded, RJ45 plug with clip
XW582 + XW586	CLMMI00N22 Operator Interface	See XW582 and XW586
XW884	Adapter cable for Excel 500/600 Controllers	0.2 m, shielded, RJ45 – 9 pin sub-D
XW885	Laptops	3 m, shielded, RJ45 plug with clip
XW585 + XW586	Laptops	See XW582 and XW586
XW586	Modems	1.8 m, RJ45 – 9 pin sub-D

Table 14 Preconfigured connection cables

### XW882 Cable Details

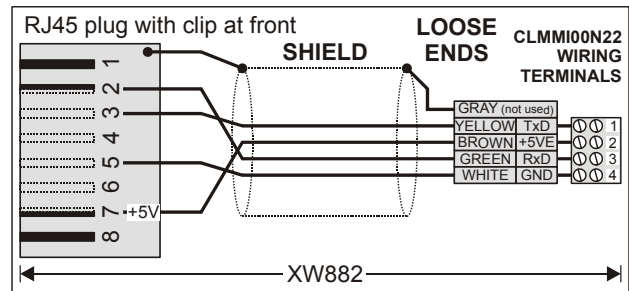

Fig. 5 CLLIONLC01/CLMMI00N22 cable details

### XW884 Cable Details

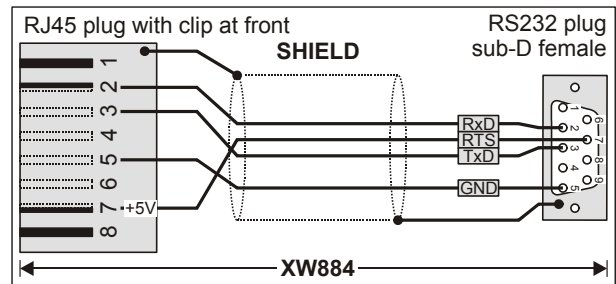

Fig. 6 CLLIONLC01/Excel 500/600 cable details

**XW885 Cable Details**

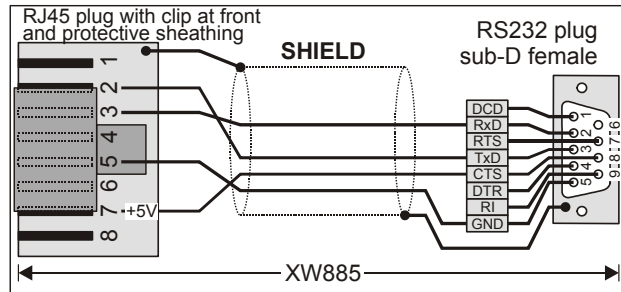

Fig. 7 CLLIONLC01/laptop cable details

**XW582 Cable Details**

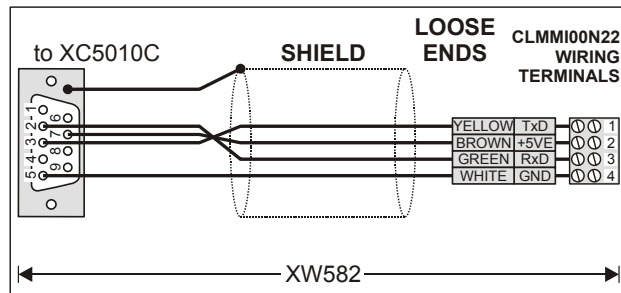

Fig. 8 XW582 cable details

**XW585 Cable Details**

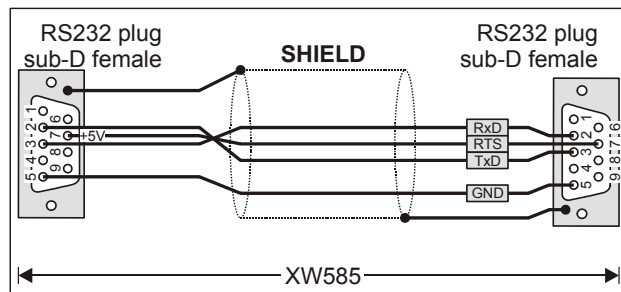

Fig. 9 XW585 cable details

**XW586 Cable Details**

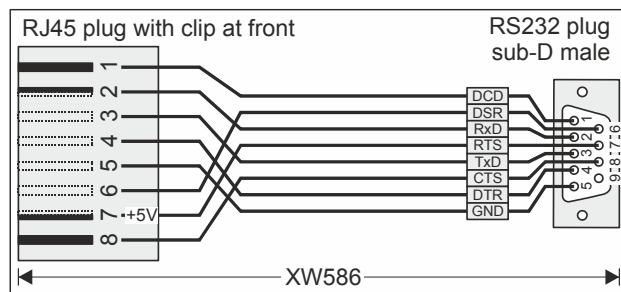

Fig. 10 XW586 cable details

**LONWORKS Bus Termination Modules**

Type	Description
XAL-Term2	LONWORKS connection and termination module, which can be mounted on DIN rails and in fuse boxes

Table 15 LONWORKS Bus termination modules

**Cable Specifications**

**Power Supply Cables**

When checking the length of the power supply cable, the connection cables to all I/O modules must be taken into account.

<b>Max. length</b>	3 m (per side of the controller), see Fig. 32 on page 24
<b>Cross section</b>	min. 0.75 mm <sup>2</sup> (AWG 18)

Table 16 Power supply cables specification

**Panel Bus Cables**

<b>Max. length</b>	40 m
<b>Cable type</b>	twisted pair, e.g., J-Y-Y 2 x 2 x 0.8

Table 17 Panel Bus cables specification

### LONWORKS Bus Cables

Cable type	Max. bus length
Belden 85102 (plenum)	2700 m (8900 ft)
Belden 8471 (non-plenum)	2700 m (8900 ft)
Level IV, 22 AWG	1400 m (4600 ft)
JY (St) Y 2 x 2 x 0.8	900 m (3000 ft)
TIA568A Cat. 5 24AWG, twisted pair	900 m (3000 ft)

Table 18 Doubly-terminated bus specifications

**NOTE:** The above-listed cable types are as recommended by Echelon in their FTT-10A User Guide.

**NOTE:** Centraline recommends the use of level IV, 22 AWG, solid core, non-shielded cable.

**NOTE:** Belden part numbers are 9H2201504 (plenum) and 9D220150 (non-plenum).

#### FTT Specification

The FTT specification includes two components that must be met for proper system operation:

- The distance from each transceiver to all other transceivers and to the termination must not exceed the max. node-to-node distance.
- If multiple paths exist, the max. total wire length is the total amount of wire used.

Cable type	Max. node-to-node distance	Max. total wire length
Belden 85102	500 m (1650 ft)	500 m (1650 ft)
Belden 8471	400 m (1300 ft)	500 m (1650 ft)
Level IV, 22AWG	400 m (1300 ft)	500 m (1650 ft)
JY (St) Y 2 x 2 x 0.8	320 m (1050 ft)	500 m (1650 ft)
TIA568A Cat. 5 24AWG, twisted pair	250 m (825 ft)	450 m (1500 ft)

Table 19 Free topology (singly-terminated) specifications

### NOTICE

#### Unpredictable reflections on the bus due to step change in line impedance characteristics!

- ▶ Do not use different wire types or gauges on the same LONWORKS network segment.

**NOTE:** In the event that the limit on the total wire length is exceeded, the FTT physical layer repeaters (FTT 10A) can be added to interconnect segments. This increases the overall length by an amount equal to the original specification for that cable type and bus type for each repeater used. For example, adding repeaters for a doubly-terminated bus using JY (St) Y 2 x 2 x 0.8 cable increases the max. length by 900 m (3000 ft) for each repeater.

### Field Device Cables

Type of signal	Cross-sectional area	
	≤ 100 m (300 ft) (Fig. 39 on p. 28) one transformer	≤ 400 m (1300 ft) (Fig. 40 on p. 28) separate transformers
24 VAC power	1.5 mm <sup>2</sup> (16 AWG)	not allowed for > 100 m (300 ft)
0...10 V signals	0.081 – 2.08 mm <sup>2</sup> (28 – 14 AWG)	

Table 20 Cable sizing for connection of field devices

For wiring field devices see page 28.

## C-Bus Cables

**NOTE:** Observe national regulations for C-Bus cables!  
 For Europe; only shielded cable is permitted.  
 For the U.S., shielded or unshielded cable can be used.

Cable type	Description	Recommended for
J-Y-(ST)Y 2 x 2 x 0.8	shielded, twisted pair	Europe, inside cabinet
A-Y-(ST)Y 2 x 2 x 0.8	shielded, twisted pair	Europe, outside cabinet
AK 3702	unshielded, twisted pair	US not approved for Europe
AK 3740A	shielded	US (low-cost) not approved for Europe
Belden 9842	twisted pair	Europe, US also possible
Belden 9841	shielded	US
AK 3702	unshielded, twisted pair	US not approved for Europe
AK 3740A	shielded	US (low-cost) not approved for Europe

Table 21 C-Bus cable types

### Max. Cable Length

The max. C-Bus cable length is 1200 m (4000 ft).

See section "C-Bus Topologies" on page 10.

## Dimensions

### Controller Module

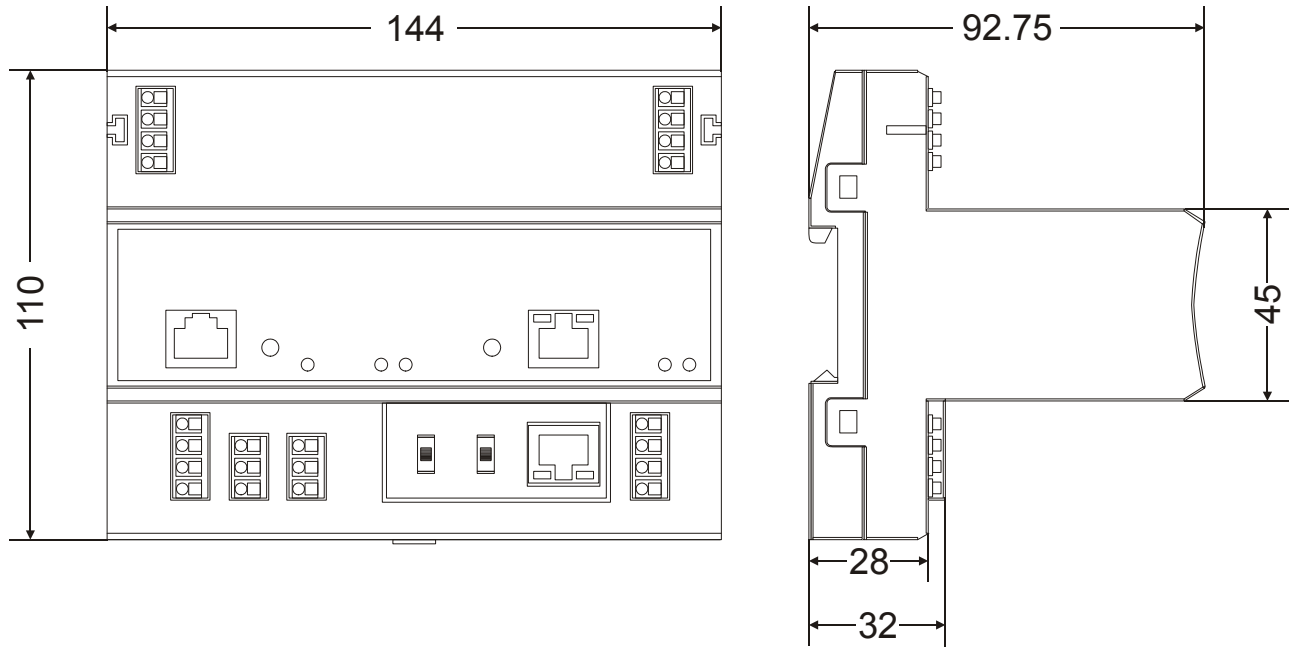

Fig. 11 Controller module, outside dimensions (in mm)

### Pluggable I/O Modules

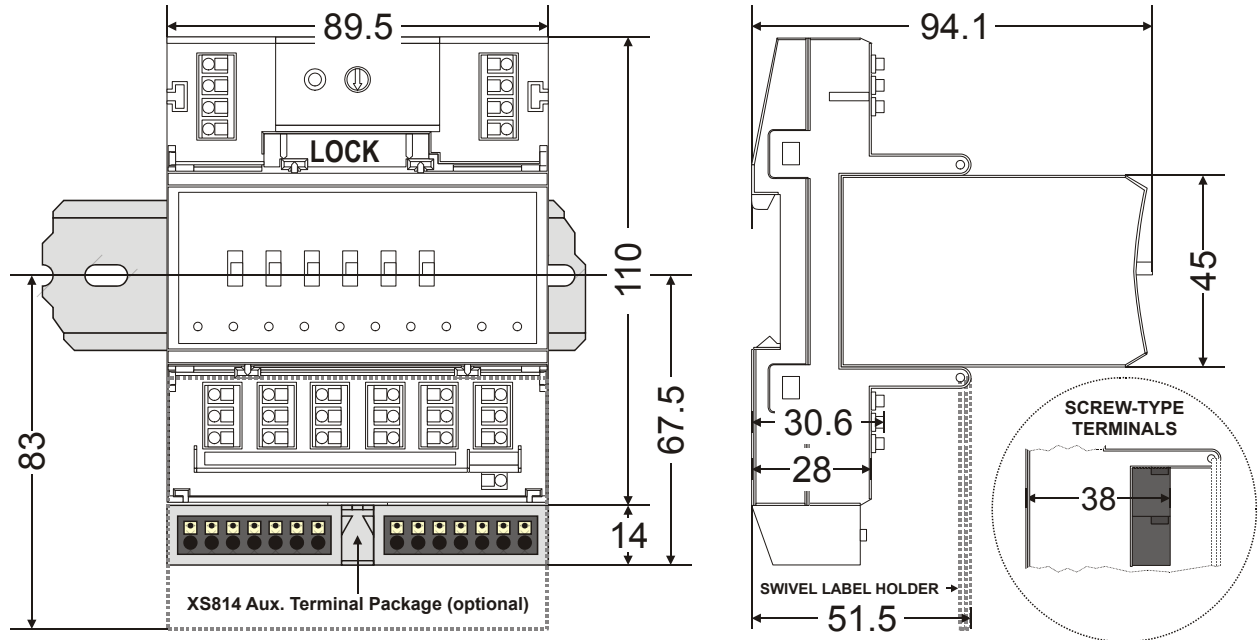

Fig. 12 Pluggable I/O modules (shown with manual overrides), including XS814 Aux. Terminal Package, dimensions (in mm)

Mixed I/O Module

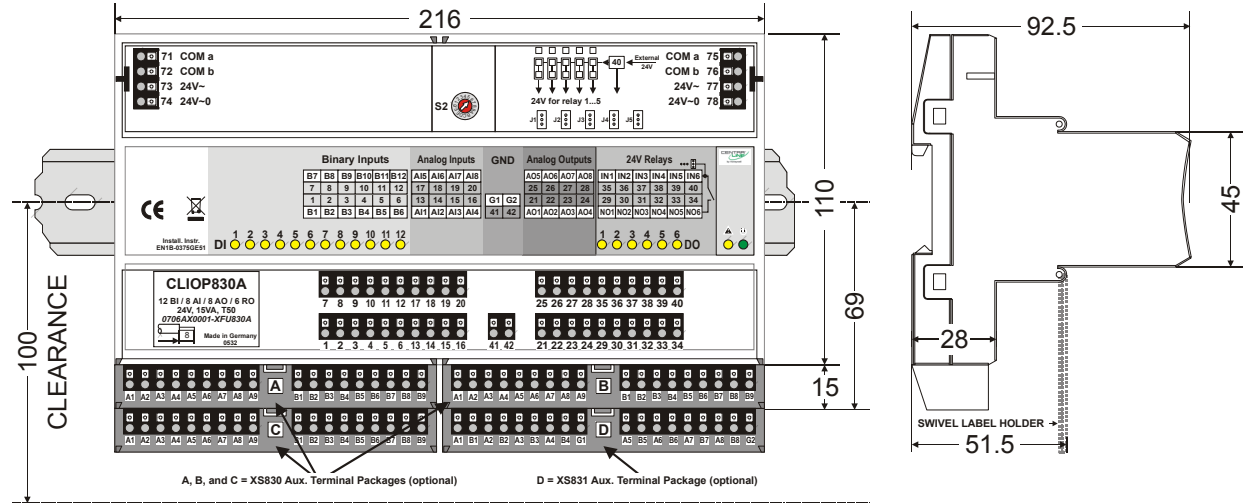

Fig. 13 Mixed I/O Module CLIOP830A (shown with four auxiliary terminal packages), dimensions (in mm)

# Mounting/Dismounting Modules

## ⚠ WARNING

### Risk of electric shock or equipment damage!

- ▶ Do not touch any live parts in the cabinet.
- ▶ Disconnect the power supply before you start to install the LION System.  
More than one disconnect switch may be required to de-energize the system.
- ▶ Do not reconnect the power supply until you have completed the installation.
- ▶ Unused terminals must be closed (by completely screwing in the terminal screws), thus preventing the accidental touching of "live" parts.

**NOTE:** The terminal socket of each pluggable I/O module can be mounted and wired before inserting and locking the corresponding electronic module.

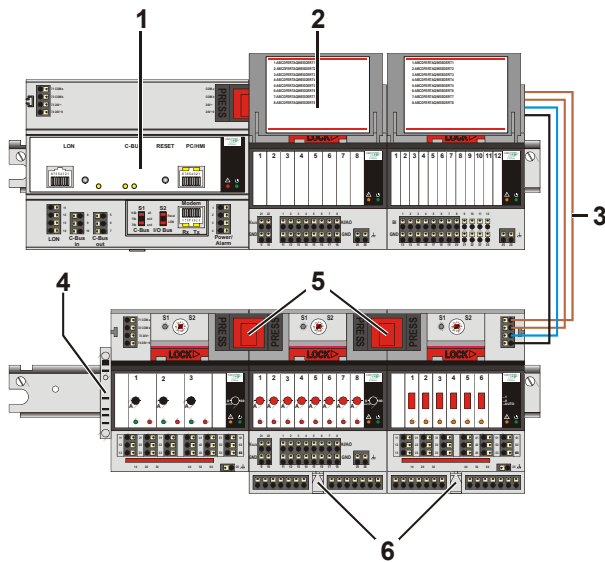

Fig. 14 CLLIONLC01 and I/O modules mounted on multiple DIN rails

### Legend

- 1 CLLIONLC01
- 2 Swivel label holder
- 3 Cable connection
- 4 Stopper (from 3<sup>rd</sup>-party supplier)
- 5 Bridge connectors
- 6 Auxiliary terminal package

## Mounting/Dismounting Controller/sockets

### Mounting Sockets

**NOTE:** When using both Panel Bus and LONWORKS Bus I/O modules in a LION System, group both Panel Bus modules (light gray) and LONWORKS Bus I/O modules (dark gray), e.g., on different rails.

**NOTE:** Up to 10 Panel Bus I/O modules can be mounted to one side of the controller. In total, up to 16 Panel Bus I/O modules can be mounted to one controller.

**NOTE:** The CLLIONLC01 and the mixed Panel Bus I/O module are mounted on the DIN rail in the same way as a terminal socket.

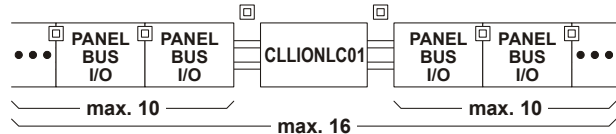

Fig. 15 Max. number of Panel Bus I/O modules

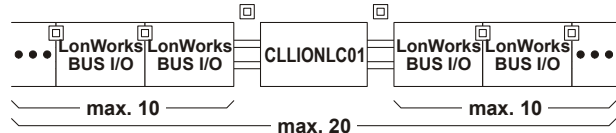

Fig. 16 Max. number of LonWorks Bus I/O modules with power supply via CLLIONLC01



- ▶ Angle the terminal socket at the upper edge of the DIN rail until it snaps in.
- ▶ Swing the terminal socket down and apply gentle force until it snaps into position with an audible "click".
- ▶ Position controller module and terminal sockets flush with one another along the rail.
- ▶ If desired, mount stoppers at the ends of the rail to prevent sliding.

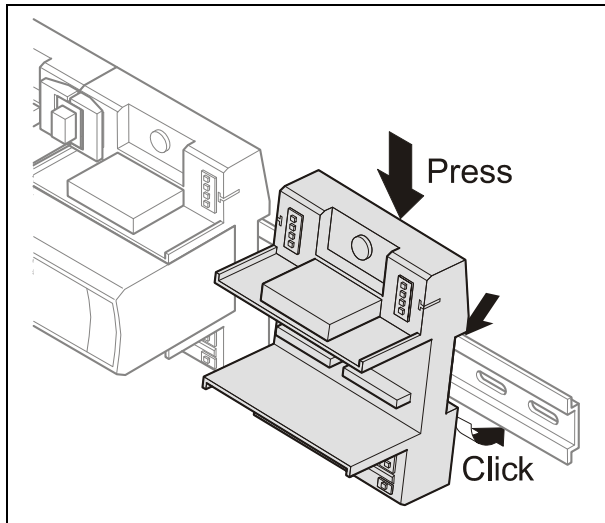

Fig. 17 Mounting terminal sockets

**NOTE:** Take care to not bend the Omega clamp, which serves to establish the electrical contact with the DIN rail and which is located on the back of the terminal socket.

## Connecting Sockets

Controller, terminal sockets, and mixed I/O modules on the same DIN rail can be connected mechanically and electrically with bridge connectors.

Controller and terminal sockets on different DIN rails must be connected using cables, see Fig. 14 and page 23.

## NOTICE

### Risk of malfunction!

- ▶ Wire Panel Bus I/O modules and LONWORKS Bus I/O modules separately.
- ▶ When using both Panel Bus and LONWORKS Bus I/O modules in a LION System, LONWORKS Bus I/O modules must be connected to the controller via LON terminals 11 ... 14.

Position the bridge connector on terminals 71 ... 74 of the right hand terminal socket or mixed I/O module or controller and on terminals 75 ... 78 of the left hand terminal socket or mixed I/O module or controller. Then press the bridge connector down.

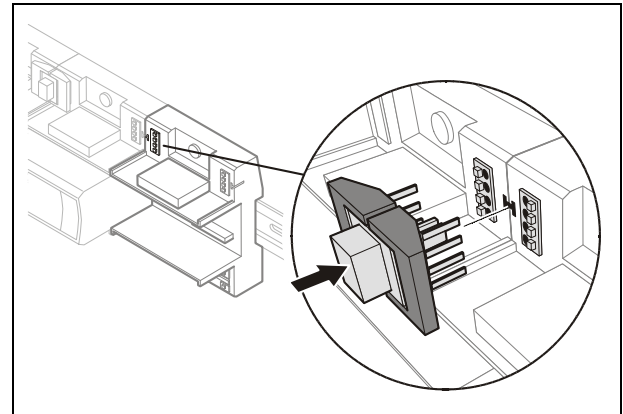

Fig. 18 Connecting terminal sockets with bridge connector

**NOTE:** Bridge connectors transmit both communication signals and power supply between modules. Removing bridge connectors will thus interrupt the transmission of both communication signals and power supply between the modules.

## Dismounting Sockets

### Disconnecting Sockets

Release all bridge connectors before removing the controller module and/or the terminal sockets and/or mixed I/O modules from the DIN rail.

- ▶ Press down at the same time both the gray side wings next to the red button and then pull the bridge connector out of the module.

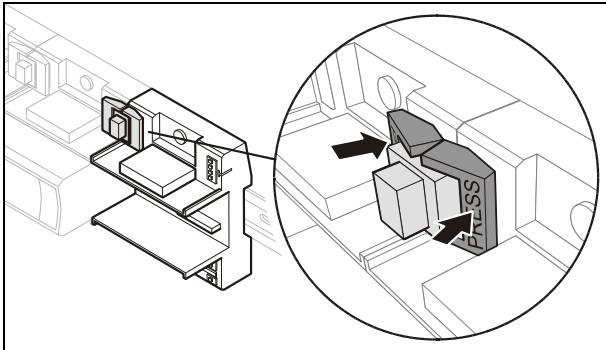

Fig. 19 Releasing bridge connectors

### Dismounting Controller / Terminal Sockets / Mixed I/O Modules

- ▶ Insert a screwdriver into the latch on the underside of the module and lever the red latch 2–3 mm downwards. The module can then be swung away from the rail.

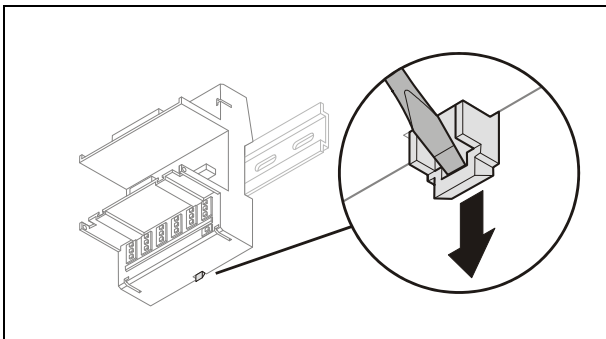

Fig. 20 Releasing latch

## Mounting/Dismounting Electronic Modules

### Mounting Electronic Modules

**NOTE:** Electronic modules can be removed from the socket or inserted into the sockets without switching off the power supply, but the resultant behavior of connected field devices must be taken into consideration.

- ▶ Make sure that terminal socket and electronic I/O module match; see Table 4 on page 5.
- ▶ Make sure that the red locking mechanism is in the open, i.e., left, position.
- ▶ Gently push the electronic module onto the terminal socket until snug.

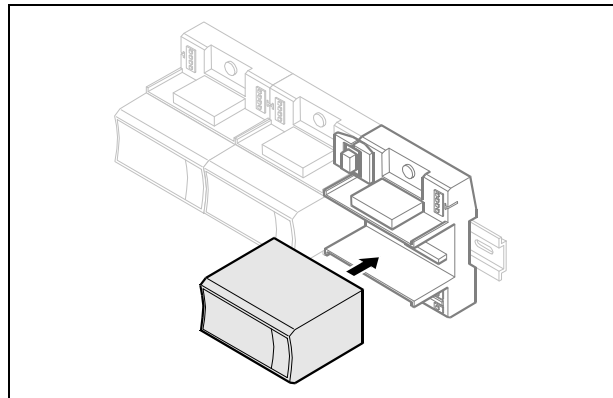

Fig. 21 Inserting the electronic module

- ▶ Lock the red locking mechanism by sliding it to the right.

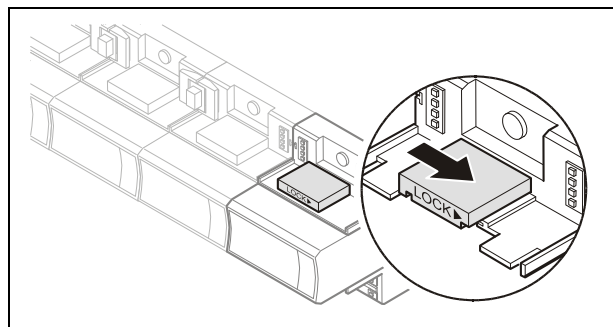

Fig. 22 Locking the electronic module

**NOTE:** The red locking mechanism will not close if the electronic module is not properly mounted.

## Dismounting Electronic Modules

**NOTE:** Electronic modules can be removed from the socket or inserted into the sockets without switching off the power supply, but the resultant behavior of connected field devices must be taken into consideration.

- ▶ Open the red locking mechanism by sliding it to the left and then gently pull the electronic module out of the terminal socket.

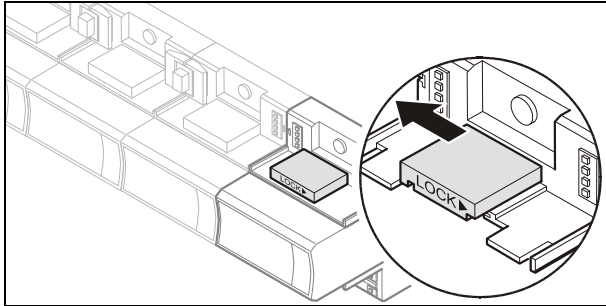

Fig. 23 Dismounting the electronic module

## Mounting/Dismounting Manual Disconnect Modules

XS812 and XS812RO Manual Disconnect Modules are mounted on the terminal socket appropriate for the electronic module, see Table 4 on page 5. The electronic module is mounted onto the manual disconnect module.

### WARNING

**Risk of electric shock or equipment damage!**  
The XS812RO Manual Disconnect Module is designed for 24 V applications only!

- ▶ Never use the XS812RO Manual Disconnect Module with line voltage.

## Mounting Manual Disconnect Modules

- ▶ Make sure that manual disconnect module, electronic module and terminal socket match, see Table 4 on page 5.
- ▶ Make sure that the red locking mechanism is in the open, i.e., left, position.
- ▶ Gently push the manual disconnect module onto the terminal socket until snug.
- ▶ Lock the red locking mechanism by sliding it to the right.

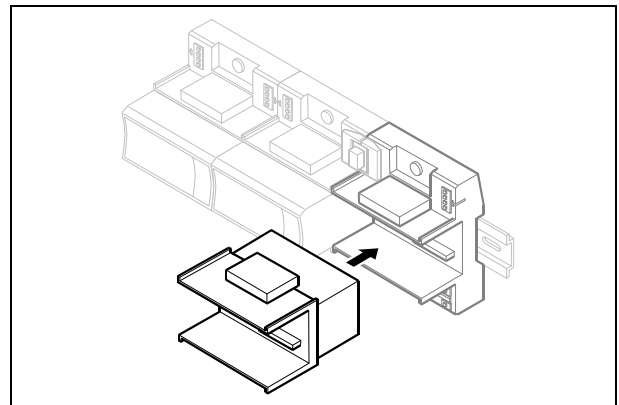

Fig. 24 Mounting the manual disconnect modules

### Operating the Individual Switches

- ▶ Use a screwdriver to open/close the appropriate disconnect switches of the manual disconnect modules.

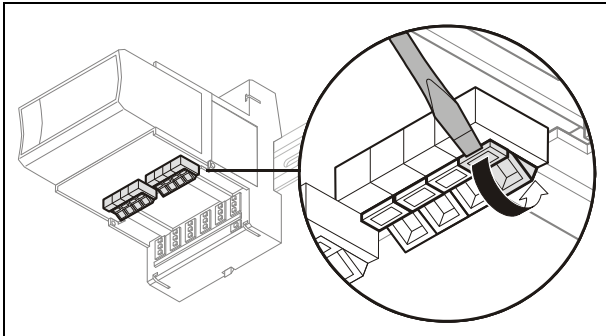

Fig. 25 Operating the disconnect switches

### Dismounting Manual Disconnect Modules

- ▶ Open the red lock mechanism by sliding it to the left and then gently pull the electronic module out of the terminal socket.

### Mounting/Dismounting Auxiliary Terminal Packages

The XS814 Auxiliary Terminal Package can be mounted on any pluggable I/O module.

The XS830 and XS831 Auxiliary Terminal Packages are suitable for mixed I/O modules, only. Specifically, they can be mounted on the top and/or bottom of the CLIOP830A.

For reasons of mechanical stability, a max. of two rows of Auxiliary Terminal Packages may be mounted together on the CLIOP830A.

### Mounting Auxiliary Terminal Packages

- ▶ Push the auxiliary terminal package onto the grooves of the corresponding terminal socket / the mixed I/O module.

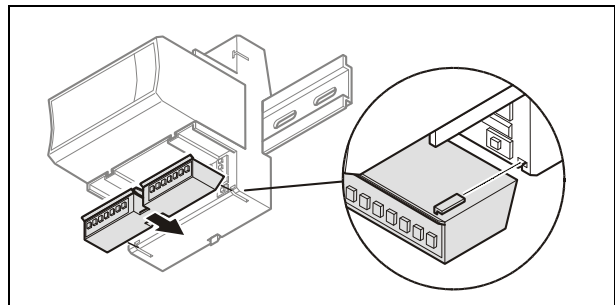

Fig. 26 Mounting the auxiliary terminal package onto the terminal socket / mixed I/O module

### Dismounting Auxiliary Terminal Packages

- ▶ Push down the catch of the auxiliary terminal package and pull it out of the grooves of the terminal socket / the mixed I/O module.

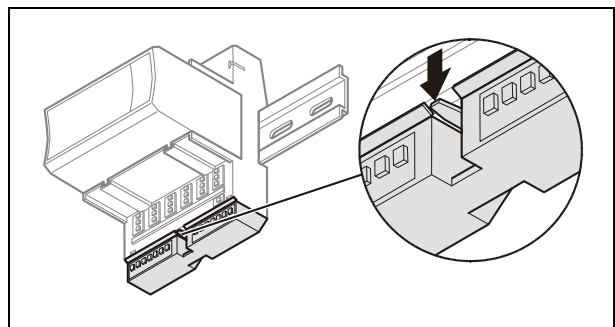

Fig. 27 Dismounting the auxiliary terminal package from the terminal socket / the mixed I/O module

## Mounting/Dismounting Cross Connectors

**NOTE:** The cross connector (incl. in the delivery) can be mounted to the XS824-25 or XSU824-25, as required. It can be dismantled (see Fig. 28). It is not permitted to replace cross connectors with wire.

- ▶ Insert a screwdriver on one end of the cross connector and swivel it to the right and to the left.
- ▶ Insert a screwdriver on the other end of the cross connector and swivel it to the right and to left until the cross connector is released.
- ▶ If desired, insert another cross connector.

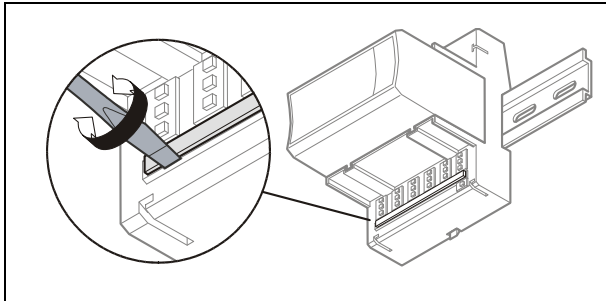

Fig. 28 Dismounting the cross connectors

## Mounting/Dismounting Swivel Label Holders

**NOTE:** A swivel label holder is included in the delivery of each module.

Use only the (short / long) swivel label holders appropriate for the given type (pluggable or mixed, respectively) of I/O module.

### Mounting Swivel Label Holders

- ▶ Snap the swivel label holder onto the hinges of the terminal socket / mixed I/O module.
- ▶ Apply self-adhesive labels to the holders.

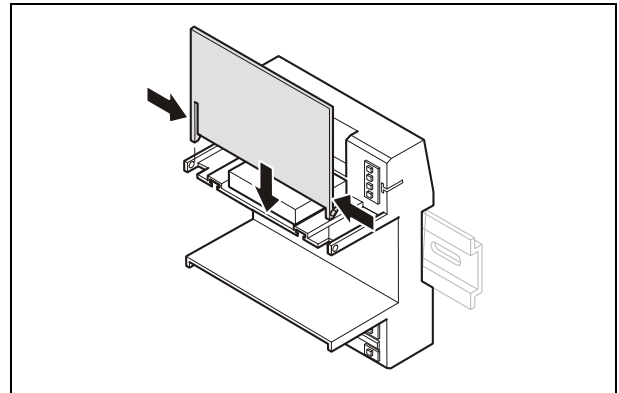

Fig. 29 Mounting the swivel label holder

### Dismounting Swivel Label Holders

- ▶ Press the hinges together and remove the swivel label holder.

# Wiring and Setting Up the System

## General Safety Considerations

- When connecting the CLLIONLC01 or LION I/O modules, both VDE, National Electric Code (NEC) or equivalent, and any local regulations concerning grounding and zero voltage must be observed.
- Electrical work should be carried out by a qualified electrician.
- The electrical connections must be made at the terminal blocks. The corresponding connection diagrams are located on the individual controller module and I/O modules.
- For Europe only: To comply with CE requirements, devices with a voltage in the range of 50 ... 1000 VAC or 75 ... 1500 VDC, which are not provided with a supply cord and plug or with other means for disconnection from the supply having a contact separation of at least 3 mm in all poles, must have the means for disconnection incorporated in the fixed wiring.

### WARNING

#### Risk of electric shock or equipment damage!

- ▶ Do not touch any live parts in the cabinet.
- ▶ Disconnect the power supply before making connections to or removing connections from terminals of controller or I/O modules.
- ▶ Do not use spare terminals as wiring support points.
- ▶ Do not reconnect the power supply until you have completed the installation.
- ▶ Unused terminals must be closed (by completely screwing in the terminal screws), thus preventing the accidental touching of "live" parts.

- ▶ Observe precautions for handling electrostatic sensitive devices.



## Wiring Push-in Terminals

The terminal sockets of the pluggable I/O modules are available in versions (XS821-22, XS823, and XS824-25) featuring convenient push-in terminals for easy wiring. The CLIOP830A likewise features push-in terminals.

For correct wiring, cables must fulfill the following specifications according to IEC664-1 / VDE 0110 (4.97):

<b>Max. plug gauge</b>	0.14 ... 1.50 mm <sup>2</sup>
<b>Solid conductor H05(07) V-U</b>	0.25 ... 1.50 mm <sup>2</sup>
<b>Stranded conductor H05(07) V-K</b>	0.25 ... 1.50 mm <sup>2</sup>
<b>Stranded conductor with wire end ferrules (without plastic collar)</b>	0.25 ... 1.50 mm <sup>2</sup>
<b>Stripping length</b>	8.0 +1.0 mm

Table 22 Push-in terminals wiring specifications

**NOTE:** In the case of solid conductors, the use of ferrules is prohibited.

**NOTE:** Use only one conductor per push-in terminal.

**NOTE:** If two stranded wires are to be connected to a single push-in terminal, twin wire end ferrules must be used.

## Wiring Screw-Type Terminals

The terminal sockets of the pluggable I/O modules are also available with screw-type terminals (XSU821-22, XSU823, and XSU824-25).

For correct wiring, cables must fulfill the following specifications according to IEC664-1 / VDE 0110 (4.97):

<b>Max. plug gauge</b>	0.14 ... 1.50 mm <sup>2</sup>
<b>Solid conductor H05(07) V-U</b>	0.25 ... 1.50 mm <sup>2</sup>
<b>Stranded conductor H05(07) V-K</b>	0.25 ... 1.50 mm <sup>2</sup>
<b>Stranded conductor with wire end ferrules (without plastic collar)</b>	0.25 ... 1.50 mm <sup>2</sup>
<b>Stripping length</b>	11.0 +1.0 mm

Table 23 Screw-type terminals wiring specifications

## Connecting Power Supply

The LION System can be powered by one or more external transformers.

**NOTE:** The max. length for the power supply cable from a transformer is 3 m. This also includes the length of the modules and the connection cables between the rails.

**NOTE:** Referring to Fig. 30, the following conditions must be fulfilled:  $A \leq 3$  m and  $B \leq 3$  m

### Single or the First Transformer

- ▶ Connect the transformer to terminals 1 and 2 of the CLLIONLC01 Controller.

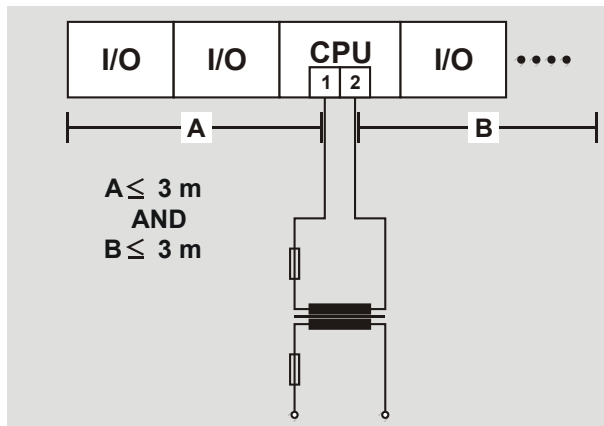

Fig. 30 Wiring power supply from the (first) transformer to the controller module

### Additional Transformer

- ▶ Connect the additional transformer in a second room or cabinet to terminals 73 and 74 or 77 and 78 of an I/O module.

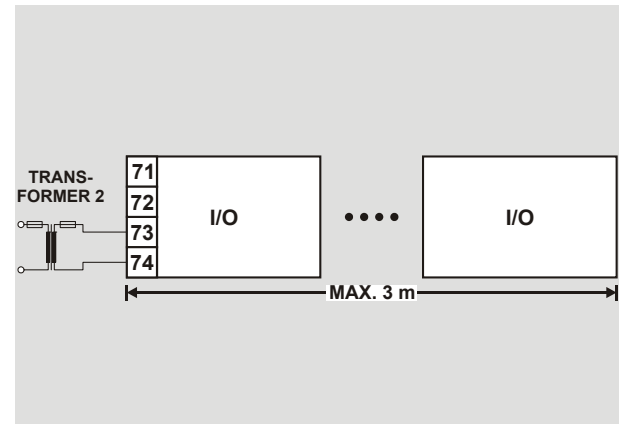

Fig. 31 Wiring the power supply from a second transformer

## NOTICE

### Equipment damage!

- ▶ Do not use bridge connectors to connect modules powered by different transformers.
- ▶ When connecting modules powered by different transformers using cables, be sure to not connect terminals 73 and 77.

## Connecting Single Bus Controller Systems

This section describes how to connect a controller system which uses **Panel Bus I/O modules only** or **LONWORKS Bus I/O modules only**.

### Controller and I/O Modules on a Single Rail

- ▶ Connect controller and I/O modules using the bridge connectors.

This provides power supply and communication connection. No further wiring is necessary.

### Controller and I/O Modules on Several Rails in a Single Cabinet

The rails of a controller system are connected in series.

- ▶ Connect the rail ends as follows:
  - **Power supply**  
via power supply terminals 73, 74 or 77, 78
  - **Communication**  
via communication terminals 71, 72 or 75, 76

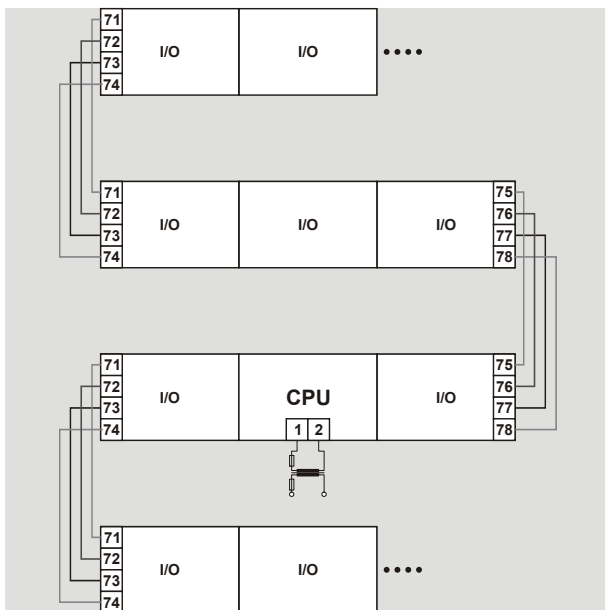

Fig. 32 Wiring the power supply and the communication lines to the I/O modules

### Max. Power Cable Length

The max. length for power supply cable per side is 3 m. This includes the connection cables between the rails, the lengths of the modules, and the cable from the transformer.

## Panel Bus I/O Modules in Separate Rooms

In this scenario, communication and reference voltage (24 V0) must be connected between the rooms.

- ▶ Connect the last module of room 1 to the first module of room 2:
  - **Reference voltage**  
via power supply terminals 74 or 78  
terminals 73 and 77 must not be connected
  - **Communication**  
via communication terminals 71, 72 or 75, 76

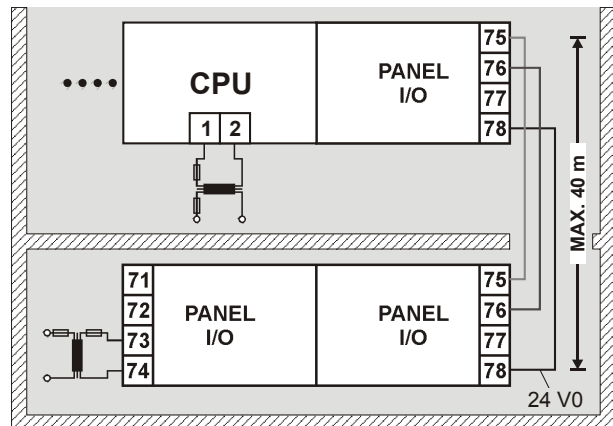

Fig. 33 Wiring the Panel Bus I/O modules in separate rooms

### Max. Cable Length

The max. cable length for connecting room 1 and room 2 is 40 m.



## LonWorks Bus I/O Modules in Separate Rooms

In this scenario, only communication lines must be connected between the rooms.

- ▶ Connect the last module of room 1 to the first module of room 2:
  - via communication terminals 71, 72 or 75, 76

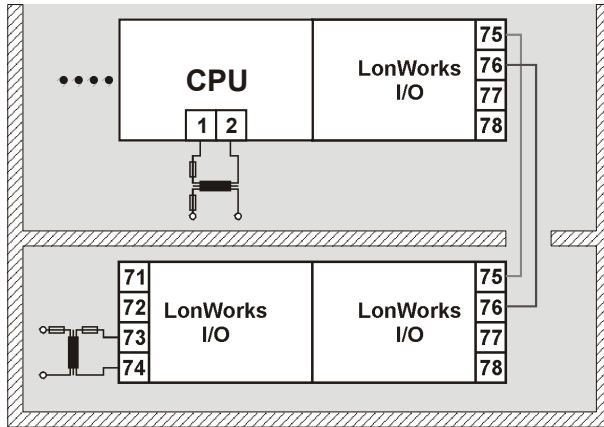

Fig. 34 Wiring the LonWorks Bus I/O modules in separate rooms

### Max. Cable Length

For max. cable lengths and cable specifications of the communication lines, see Table 18 and Table 19 on page 12.

## Connecting Panel Bus and LonWorks Bus Mixed Controller Systems

### Connecting I/O Modules with Each Other

For connecting the I/O modules with each other, proceed as described for single bus controller systems on page 23.

### Connecting I/O Modules to the Controller

#### Panel Bus I/O Modules

- ▶ Connect communication terminals 71/72 or 75/76 of Panel Bus I/O modules to communication terminals 71 ...74 or 75... 78 of the controller module using either
  - Bridge connectors (for flush mounting on a single DIN rail) or
  - Cables (for separate mounting, e.g., on multiple rails, separate cabinets, etc.).

#### LONWORKS Bus I/O Modules

- ▶ Connect communication terminals 71/72 or 75/76 of LONWORKS Bus I/O modules to LONWORKS terminals 11 ... 14 of the controller module using cables. See also section "LonWorks Bus Termination" on page 30 and the section on "LONWORKS Wiring" in the separate document LONWORKS Mechanisms (Product Literature no.: EN0B-0270GE51).

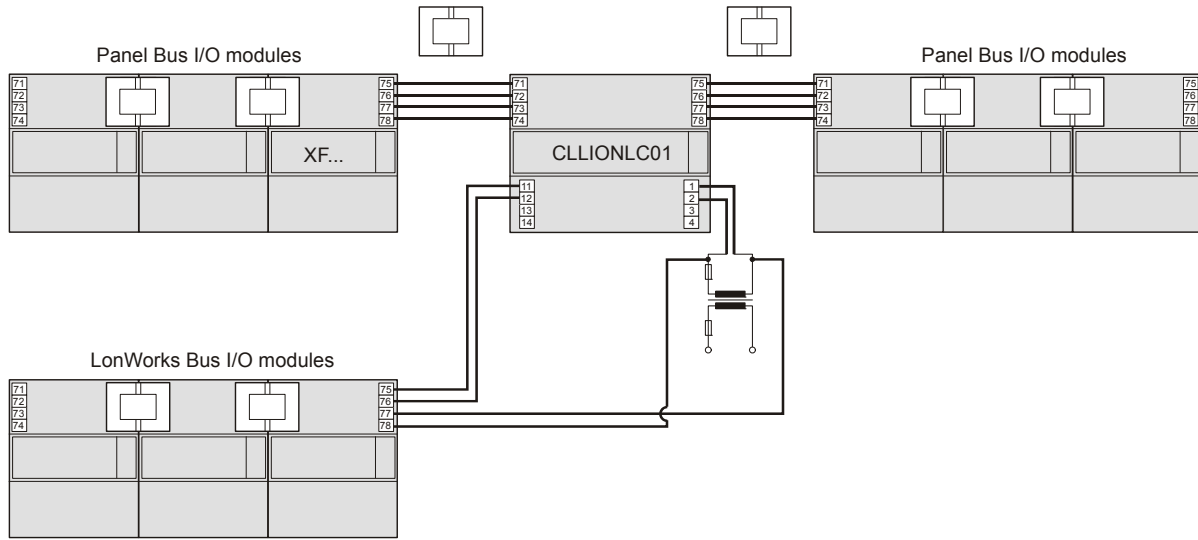

Fig. 35 Mixed bus system – correct wiring

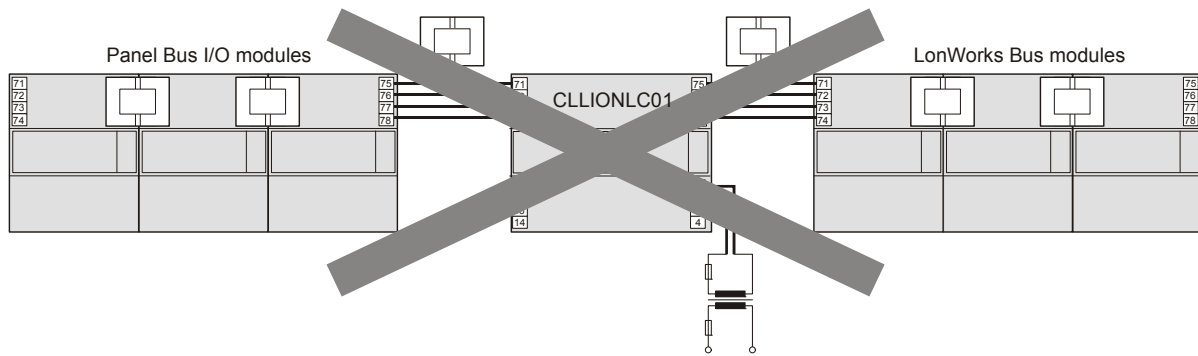

Fig. 36 Mixed bus system – incorrect wiring

## Setting Address of Panel Bus I/O Modules

During engineering, each Panel Bus I/O module is assigned its own unique address. For the sake of clarity for maintenance personnel, it is recommended that you address the Panel Bus I/O modules in ascending order 0 through F.

Hex switch	0	1	2	3	4	5	6	7
Address	01	02	03	04	05	06	07	08

Hex switch	8	9	A	B	C	D	E	F
Address	09	10	11	12	13	14	15	16

Table 24 HEX switch settings and addresses

- Use the rotary HEX switch to set the address to the one already defined using the engineering tool.

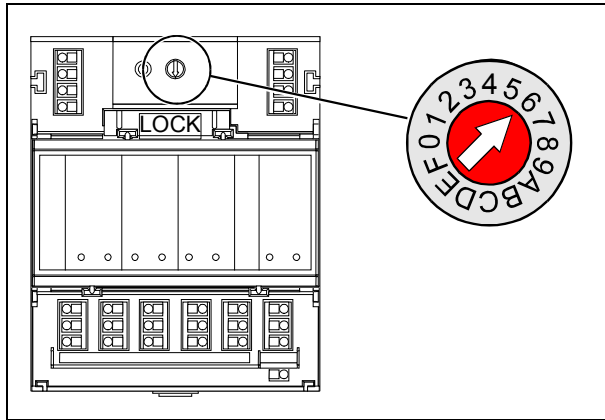

Fig. 37 HEX switch location

- NOTE:** If the HEX switch is changed, the Panel Bus I/O module will revert to its default configuration.
- NOTE:** With LONWORKS Bus I/O modules, the HEX switch is without function.

## Setting I/O Bus Switch

- Set the I/O Bus switch S2 of the CLLIONLC01 depending on the modules connected to terminals 71 ... 78 and the desired communication as follows:

Communication	S2 setting	Terminals
LONWORKS Bus only	LON	71 ... 74 LONWORKS Bus 75 ... 78 LONWORKS Bus 11 ... 14 LONWORKS Bus
Panel Bus and LONWORKS Bus	Panel	71 ... 74 Panel Bus 75 ... 78 Panel Bus 11 ... 14 LONWORKS Bus

Table 25 I/O Bus switch settings

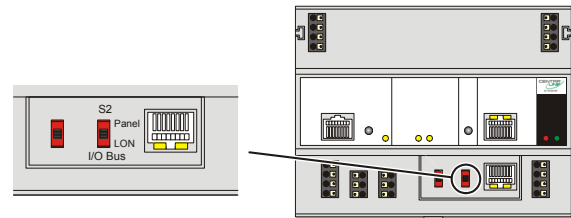

Fig. 38 S2 I/O Bus switch

## Connecting Field Devices

### Connecting Field Devices with Power Supply

Depending on the distance from the controller, field devices can be supplied by the controller or need a separate transformer, see Table 20 on page 12.

For fusing see section "Fusing Specifications" on page 9.

#### Example 1: Power Supply via Controller

- 24 V actuator connected to an analog output module
- Less than 100 m away from the controller

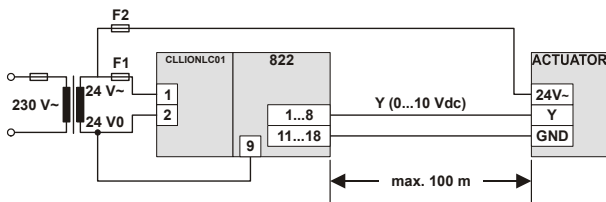

Fig. 39 Power supply of field devices via I/O module

#### Example 2: Power Supply via Separate Transformer

- 24 V actuator connected to an analog output module
- 100 ... 400 m away from the controller

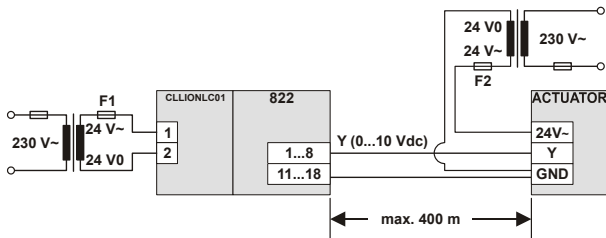

Fig. 40 Power supply of field devices via a separate transformer

## Cabling Field Devices

### Cable Routing

Route low-voltage signal and output cables separately from mains cables.

Cable	Min. distance
Shielded	10 mm (0.4 in.)
Unshielded	100 mm (4 in.)

Table 26 Min. distances to power mains cables

All low-voltage signal and output cables should be regarded as communication circuits in accordance with VDE 0100 and VDE 0800 (or NEC or other equivalent).

### Cable Shielding

- If the general guidelines for cable routing are observed, it is not necessary to shield field device signal and power supply cables.
- If, for whatever reason, the routing guidelines cannot be observed, the field device signal and power supply cables must be shielded.
  - Shielding of cables leading to field devices must be grounded only at the cabinet end.
  - The shield must not be terminated at the CLLIONLC01.

## Commissioning I/O Modules

### Commissioning Panel Bus I/O Modules

During engineering, the HEX address of the Panel I/O modules is defined.

**NOTE:** With Panel Bus I/O modules it is essential that the HEX switch be set to the address assigned by the engineering tool.

The CLLIONLC01 Controller automatically commissions all Panel Bus I/O modules.

### Commissioning LONWORKS Bus I/O Modules

Commissioning is done using the engineering tool.

## Updating Software

CARE is used to update the CLLIONLC01 Controller.

### Software with Panel Bus I/O Modules

The CLLIONLC01 Controller's firmware includes the firmware for the Panel Bus I/O modules. Thus, whenever the CLLIONLC01 Controller's firmware is updated, the firmware of the Panel Bus I/O modules is automatically updated, too.

### Example

Status before update: The CLLIONLC01 Controller was loaded with controller firmware V3.01.03, which included the corresponding Panel Bus I/O module firmware (see Fig. 41).

When the controller firmware is updated from V3.01.03 to V3.02.02, if newer firmware is available for individual Panel Bus I/O modules, their firmware will be automatically updated, too. In this example, newer Panel Bus I/O module firmware is, indeed, available for all but the CLIOP830A Mixed Panel Bus I/O modules. As a consequence, the firmware of all of the Panel Bus I/O modules – except for the CLIOP830A Mixed Panel Bus I/O modules – will be updated, accordingly.

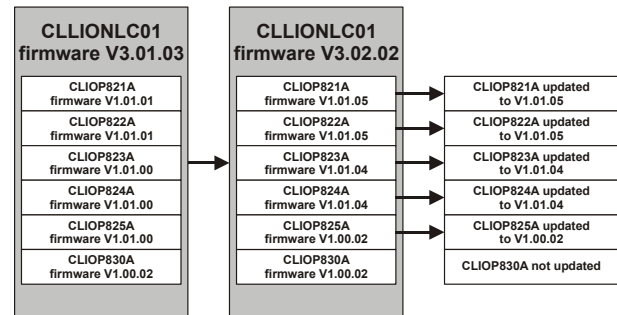

Fig. 41. Automatic updating of Panel Bus I/O module firmware (example)

### Software with LONWORKS Bus I/O Modules

You can update the LONWORKS I/O modules using CARE or EXCELON.

# Connecting to External Systems or Interfaces

## WARNING

### Risk of electric shock or equipment damage!

- ▶ Do not touch any live parts in the cabinet!
- ▶ Disconnect the power supply before making connections to or removing connections from terminals of controller or I/O modules.
- ▶ Do not reconnect the power supply until you have completed installation.
- ▶ Observe the rules regarding electrostatic discharge.

## Connecting via LONWORKS Bus

Via a LONWORKS Bus, a LION System can be connected to other controller systems, to additional LONWORKS Bus I/O modules, or to laptops.

### LONWORKS Bus Termination

Depending upon the configuration, either 1 or 2 termination modules are required for terminating a LONWORKS bus with FTT devices on it.

The following LONWORKS termination unit is available for this purpose:

- XAL-Term2 LONWORKS Connection and Termination Module, which can be mounted on DIN rails and in fuse boxes

### Termination Example

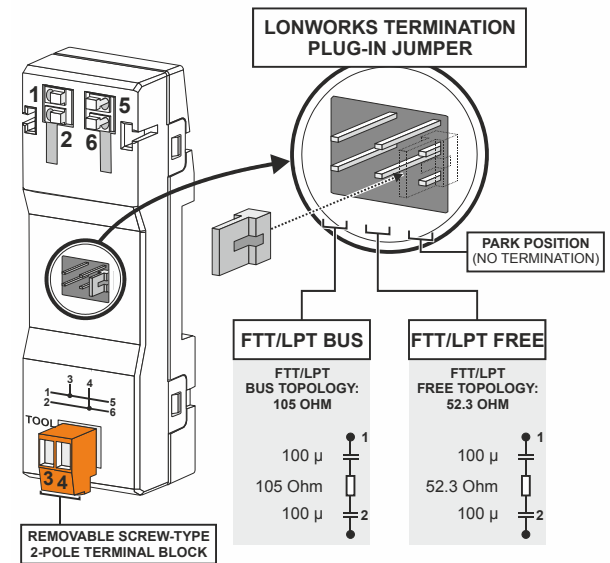

Fig. 42. XAL-Term2 Connection and Termination Module

## Connecting via C-Bus

Via C-Bus, a LION Controller can be connected to other controller systems to form a network.

### Connecting to the Controller

- ▶ Connect the C-Bus to the CLLIONLC01 as follows:
  - Input to C-Bus terminals 8 and 9
  - Output to C-Bus terminals 5 and 6
  - Do not connect the C-Bus to the cabinet earth or any other earth ground points

### Setting C-Bus Termination Switch

- ▶ Set the C-Bus termination switch S1 appropriately.

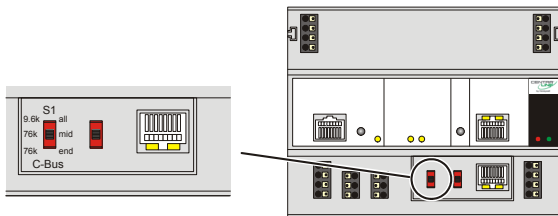

Fig. 43 C-Bus termination switch S1

Switch setting S1	Baud rate
9.6k all	Up to 9600 baud (default setting)
76k mid	Up to 76800 baud without bus termination
76k end	Up to 76800 baud with bus termination

Table 27 CLLIONLC01 C-Bus termination switch settings

### How to Shield

In principle, data transmitting cables should be shielded in case of RFI.

- ▶ On the controller side, connect the shield to terminals 7 and 10.
- ▶ On the side of the device, connect the shield to the respective terminals.  
Do not connect it to the cabinet ground or any other ground points.

## Connecting HMIs or Laptops

HMIs (e.g., the CLMMI00N22 or the CLMMI00N31) can be connected via the HMI interface of the CLLIONLC01. Laptops can be connected via the HMI interface or via the LONWORKS interface of the CLLIONLC01.

### Connecting the CLMMI00N22 Operator Interface

- ▶ Connect the CLMMI00N22 Operator Interface to the HMI interface of the CLLIONLC01 by means of
  - the XW882 cable or
  - the XW582 cable connected with an XW586 cable.

For mounting details refer to the CLMMI00N22 Installation Instructions (Product Literature no.: EN2B-0126GE51).

For cable details refer to section "Preconfigured Connection Cables" on page 10.

### Connecting the CLMMI00N31 Operator Interface

- ▶ Connect the CLMMI00N31 Operator Interface to the HMI interface of the CLLIONLC01 Controller Module by means of
  - the XW882 cable or
  - the XW586 cable connected with an XW585 cable.

For cable details refer to section "Preconfigured Connection Cables" on page 10.

### Connecting Laptops (XL-Online/CARE)

- ▶ Connect a laptop (on which, e.g., XL-Online or CARE has been installed) to the HMI interface of the CLLIONLC01 by means of
  - the XW885 cable or
  - the XW585 cable connected with an XW586 Cable.

For cable details refer to section "Preconfigured Connection Cables" on page 10.

## Connecting Modems

A LION System can be connected to a modem or an ISDN terminal adapter via the Modem Interface of the CLLIONLC01 by means of the XW586 Cable.

- ▶ Connect the RJ45 female connector of the XW586 cable to the modem interface of the CLLIONLC01 Controller.
- ▶ Connect the 9-pin sub-D connector to the modem.

For cable details refer to section "Preconfigured Connection Cables" on page 10.

Refer to Appendix 2 for details regarding remote communication.

# Description of the CLLIONLC01

## Overview

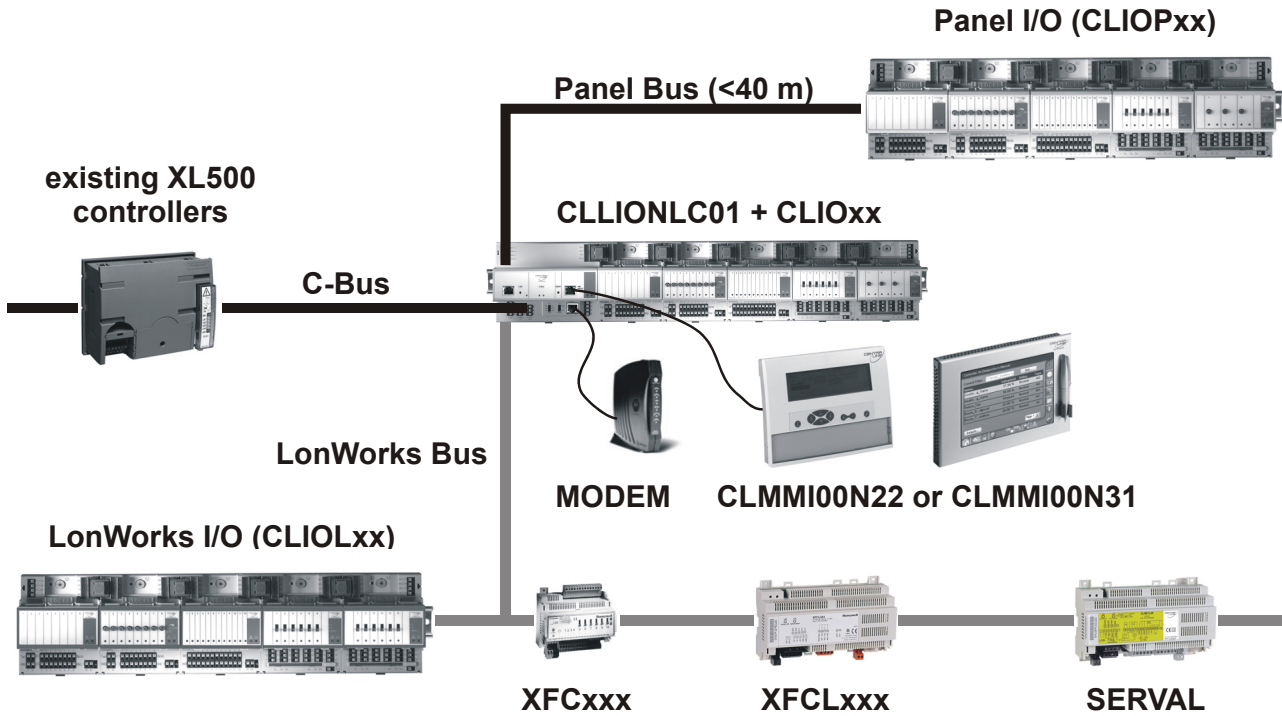

Fig. 44 Connections to the CLLIONLC01 Controller

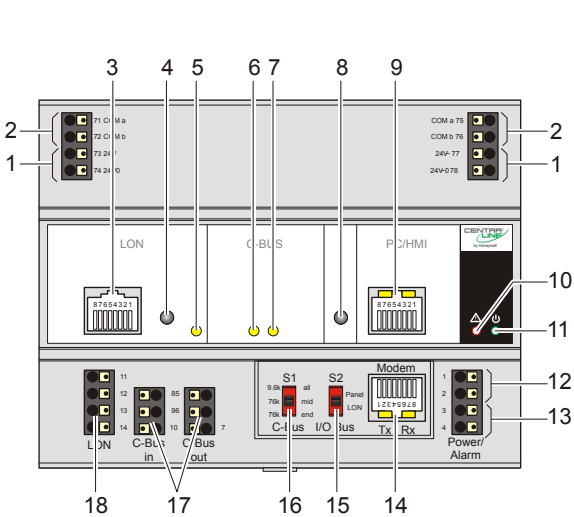

Fig. 45 CLLIONLC01, front details

### Legend

- 1 Power supply for I/O modules
- 2 I/O Bus communication terminals
- 3 LONWORKS interface
- 4 LONWORKS service button
- 5 LONWORKS service LED
- 6 C-Bus Tx LED
- 7 C-Bus Rx LED
- 8 Reset button
- 9 HMI interface and LEDs
- 10 Alarm LED
- 11 Power LED
- 12 Power supply terminals
- 13 Alarm/watchdog outputs
- 14 Modem interface and LEDs
- 15 S2 I/O Bus switch
- 16 S1 C-Bus termination switch
- 17 C-Bus terminals
- 18 LONWORKS terminals



### CLLIONLC01 Terminals

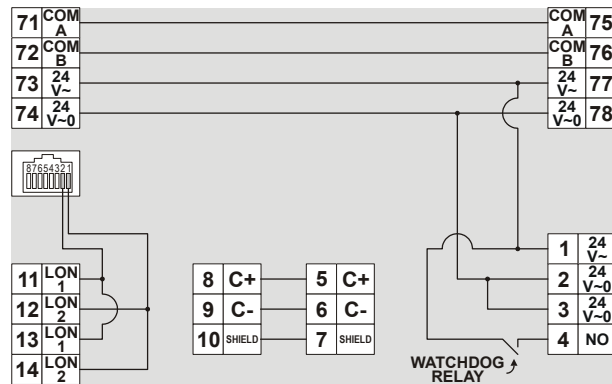

Fig. 46 Terminal assignment and internal connections of the CLLIONLC01

Terminal	Signal	Comment
71, 75	COM a	2-wire communication bus (LON/Panel Bus)
72, 76	COM b	2-wire communication bus (LON/Panel Bus)
73, 77	24 V~	Power supply for I/O modules
74, 78	24 V~0	Power supply for I/O modules
1	24 V~	Power supply from transformer
2	24 V~0	Power supply from transformer
3	24 V~0	Alarm/watchdog output
4	NO	Alarm/watchdog output
5, 8	C+	C-Bus
6, 9	C-	C-Bus
7, 10	Shield	C-Bus shield
11, 12	LON	LONWORKS IN
13, 14	LON	LONWORKS OUT

Table 28 Description of CLLIONLC01 terminals

### Features

#### LONWORKS Interface and Terminals

The CLLIONLC01 Controller Module features

- An RJ45 socket serving as an interface to connect laptops to the LONWORKS Bus
- LONWORKS terminals 11, 12, 13, and 14 to connect LONWORKS Bus I/O modules or other LONWORKS devices to the CLLIONLC01 Controller or other LONWORKS controllers.

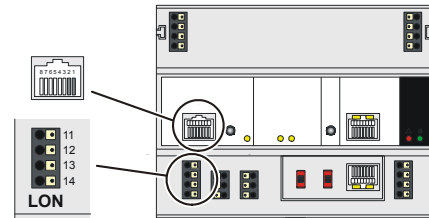

Fig. 47 LONWORKS interface and LONWORKS terminals

#### LONWORKS Interface Signals on RJ45 Socket

Pin	Signal type
1	Connection to LONWORKS Bus
2	Connection to LONWORKS Bus
3 ... 8	Not used

Table 29 Signals of LONWORKS interface

#### LONWORKS Service LED and Button

The CLLIONLC01 is equipped with a LONWORKS service button and corresponding LONWORKS Service LED (status: yellow/OFF).

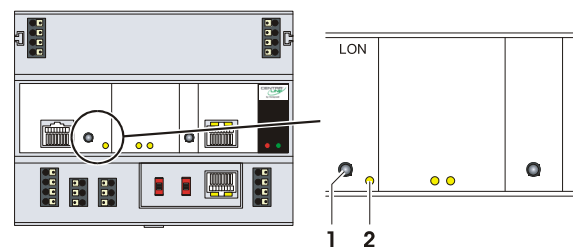

Fig. 48 LONWORKS service button (1) and service LED (2)

See also section "Troubleshooting" on page 39.

### C-Bus Tx LED and Rx LED

The CLLIONLC01 is equipped with a Tx LED (status: yellow/OFF) and an Rx LED (status: yellow/OFF).

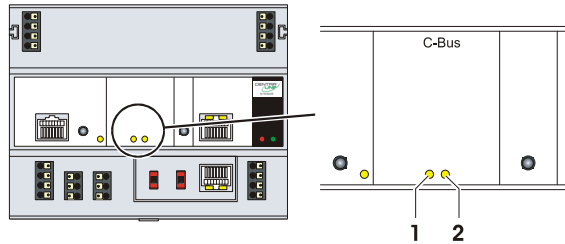

Fig. 49 C-Bus Tx LED (1) and Rx LED (2)

### C-Bus LEDs

<b>Tx (1)</b> flickering	The controller is sending data onto the C-Bus
<b>Rx (2)</b> flickering	The controller is receiving data from the C-Bus

Table 30 Controller C-Bus LEDs

### Reset Button

The CLLIONLC01 is equipped with a reset button.

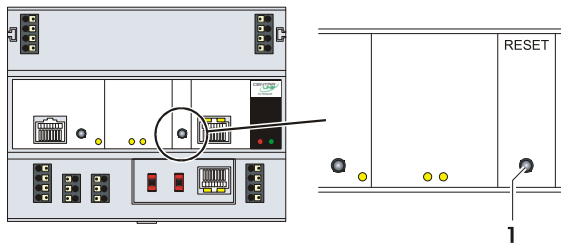

Fig. 50 Reset button (1)

Pushing the reset button (1) using, e.g., a paperclip will cause the CLLIONLC01 to reset.

**NOTE:** In the event of a reset, all non-volatile memory contents are permanently deleted, though the clock will not be set to zero. In order to avoid problems, we therefore recommend that you always save your application changes (e.g., time program changes) to FLASH memory.

### HMI Interface

The controller module is equipped with an HMI Interface for the connection of HMIs (e.g., the CLMMI00N22 or the CLMMI00N31) or a laptop (with XL-Online/CARE).

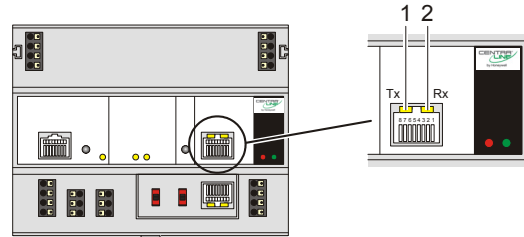

Fig. 51 HMI interface, Tx LED (1) and Rx LED (2)

### HMI interface LEDs on RJ45 socket

<b>Tx (1)</b> flickering	The controller is transmitting data to the HMI
<b>Rx (2)</b> flickering	The controller is receiving data from the HMI

Table 31 HMI interface LEDs

### HMI interface Signals on RJ45 socket

Pin	Signal type
1	-
2	Receive
3	Transmit
4	-
5	Signal ground
6	-
7	5 V
8	-

Table 32 Signals of the HMI interface

## NOTICE

### Equipment damage!

- ▶ Make sure that the controller is not connected to earth ground.
- ▶ If nonetheless earth grounding is required, make sure that only terminal 2 is connected to earth ground. Terminal 1 must not be connected to earth ground. See also Appendix 1.

## Alarm and Power LEDs

The CLLIONLC01 is equipped with an alarm LED and a power LED.

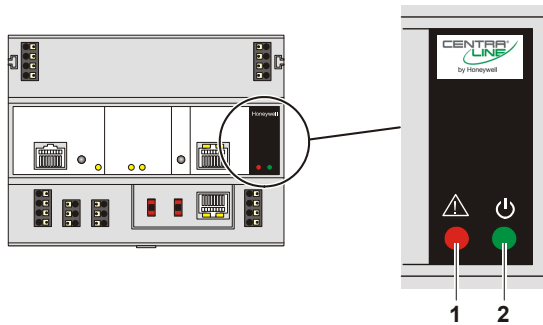

Fig. 52 Alarm LED (1) and power LED (2)

### Alarm LED (1, red)

<b>Off</b>	Normal operation
<b>On</b>	Watchdog alarm output is powered. <ul style="list-style-type: none"> <li>The controller has encountered a hardware problem.</li> <li>The application has a fault.</li> <li>The controller has been powered up without an application or the operator has manually stopped the application, e.g., using XL-Online. In this case, the LED will light up and, simultaneously, the watchdog relay will be activated 22 minutes after power-up without application.</li> </ul>
<b>Flashing</b>	The watchdog alarm output has not yet been powered, although the controller has encountered a problem. The controller performs a warm start. If the problem persists, the LED will become lit constantly, see above. See section "Troubleshooting" on page 39.

Table 33 Controller alarm LED

### Power LED (2, green)

<b>On</b>	Normal operation
<b>Flashing</b>	One or more of the internal voltage supplies are outside of the permissible ranges. The controller stops operation. ► Check wiring or see section "Troubleshooting" on page 39.
<b>Goes out briefly</b>	<ul style="list-style-type: none"> <li>The operator has activated the reset button</li> <li>The controller is performing a warm start</li> </ul>

Table 34 Controller power LED

## Watchdog

### Watchdog status

Status	Signal on terminal 4
Failure (= alarm)	24 V
Normal operation	0 V

Table 35 Watchdog status 4

### Permissible Load of Normally Open Contact (Terminal 4)

	Max. load	Min. current
<b>Per normally open contact (terminal 4)</b>	<b>19...29 VAC</b> current at $\cos \varphi \geq 0.95$ : 0.5 A, current at $\cos \varphi \geq 0.6$ : 0.5 A <b>19...29 VDC</b> 0.5 A resistive or inductive	10 mA

Table 36 Permissible load of terminal 4

### Modem Interface

The controller module is equipped with a modem interface for the connection of a modem or an ISDN terminal adapter.

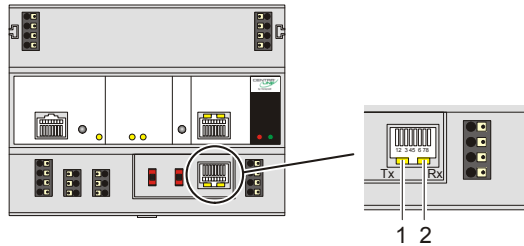

Fig. 53 Modem interface, Tx LED (1) and Rx LED (2)

#### Modem LEDs on RJ45 socket

<b>Tx (1) flickering</b>	The controller is transmitting data to the HMI, e.g., CLMMI00N22 or CLMMI00N31
<b>Rx (2) flickering</b>	The controller is receiving data from the HMI

Table 37 HMI interface LEDs

#### Modem Signals on RJ45 socket

Pin	Signal type
1	Carrier detect
2	Receive
3	Transmit
4	Data terminal ready
5	Signal ground
6	-
7	5 V
8	Clear to send

Table 38 Signals of the modem interface

### Communication Speed

Default setting: **9600 baud**

The communication speed can be set to as high as 38.4 Kbaud, e.g., using the CLMMI00N22 or CLMMI00N31 or a laptop with XL-Online, see Appendix 2.

### I/O Bus Switch S2

The CLLIONLC01 features a 2-position I/O Bus switch S2. I/O Bus switch S2 must be set in accordance with the kind of I/O modules connected to communication terminals 71, 72 and 75, 76 of the controller module.

Terminals 71, 72 and 75, 76 must be all connected either to Panel Bus I/O modules or to LONWORKS Bus I/O modules.

The **default** setting is **Panel**.

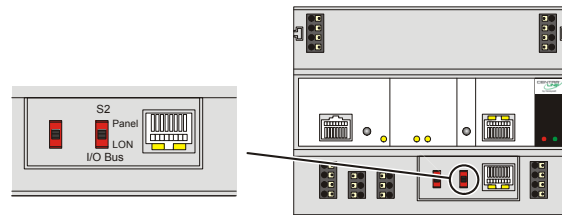

Fig. 54 I/O Bus switch S2

Communication	S2 setting
LONWORKS Bus only	LON
Panel Bus and LONWORKS Bus LONWORKS BUS modules connected to terminals 11 .... 14 of the controller	Panel
Panel Bus connected to terminals 71, 72 or 75, 76 of the controller	Panel

Table 39 I/O Bus switch settings

## C-Bus Termination Switch S1

The CLLIONLC01 features a 3-position C-Bus termination switch S1.

This switch must be set in accordance with the given C-Bus configuration.

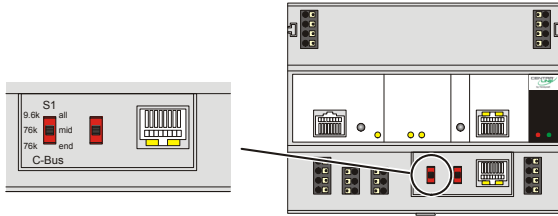

Fig. 55 C-Bus termination switch

Switch setting S1	Baud rate
9.6k all	Up to 9600 baud (default setting)
76k mid	Up to 76800 baud without bus termination
76k end	Up to 76800 baud with bus termination controller at the end of the C-Bus

Table 40 CLLIONLC01 C-Bus termination switch S1 settings

## Memory

Memory	Size	Usage
SRAM	512 KB	For controller application, modem trend and firmware RACL application: 128 KB Total application: 192 KB
Flash	2 MB	Firmware (1 MB) and application (1 MB) storage
EPROM	128 KB	For bootstrap loader

Table 41 CLLIONLC01 memory

**NOTE:** The CLLIONLC01 does not contain a battery. RAM (data and real-time clock-time) is buffered for 3 days by a super capacitor.

# Description of the I/O Modules

## Common Features

### Switches located on the Terminal Socket

Feature	Function
Service button S1 (pluggable I/O modules, only)	<ul style="list-style-type: none"> <li>LED test, see section "Troubleshooting" on page 39</li> <li>LONWORKS service button functionality for LONWORKS Bus I/O modules</li> </ul>
Hex switch S2	<ul style="list-style-type: none"> <li>Module addressing for Panel Bus I/O modules</li> </ul>

### LEDs located on the I/O Module

Feature	Function
Service LED (yellow)	<ul style="list-style-type: none"> <li>Service information, see section "Troubleshooting" on page 39</li> </ul>
Power LED (green)	<ul style="list-style-type: none"> <li>Information on power supply, see section "Troubleshooting" on page 39</li> </ul>

For detailed information on the features of the individual I/O modules, including a description of the software interface and troubleshooting, please refer to CentralLine I/O Modules – Installation and Commissioning Instructions (EN1Z-0973GE51).

# Troubleshooting

## Testing Wiring Connections

Push-in terminals feature small holes (1 mm in diameter) which can be used to measure the signals.

- ▶ Insert a probe (1) as shown on the right.

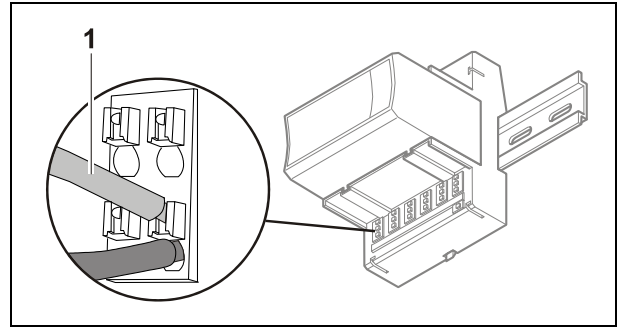

Fig. 56 Testing wiring connections

## Troubleshooting on the CLLIONLC01 Controller

The following LEDs of the CLLIONLC01 Controller can be used for troubleshooting purposes:

- Power LED (green)
- Alarm LED (red)
- LONWORKS service LED
- C-Bus Tx and Rx LEDs
- HMI Tx and Rx LEDs
- Modem Interface Tx and Rx LEDs

### Power LED (green)

case	Power LED	Meaning	Remedy
1	<b>ON</b>	Normal operation	No action necessary
2	<b>Flashing</b>	One or more of the internal voltage supplies are outside of the permissible ranges. The controller stops operation.	<ul style="list-style-type: none"> <li>▶ Check power</li> <li>▶ Check wiring</li> <li>▶ If the problem persists, replace hardware</li> </ul>
3	<b>Goes out briefly</b>	<ul style="list-style-type: none"> <li>• The operator has activated the reset button</li> <li>• The controller is performing a warm start</li> </ul>	No action necessary

Table 42 CLLIONLC01 power LED

**Alarm LED (red)**

Case	Alarm LED	Meaning	Remedy
1	OFF	Normal operation	No action necessary
2	ON	Watchdog alarm output is powered <ul style="list-style-type: none"> <li>- The controller has encountered a hardware problem</li> <li>- or -</li> <li>- The application has a fault</li> <li>- or -</li> <li>- The controller has been powered up without an application or the operator has manually stopped the application, e.g., using XL-Online. In this case, the LED will light up and, simultaneously, the watchdog relay will be activated 22 minutes after power-up without application.</li> </ul>	<ul style="list-style-type: none"> <li>▶ Try powering down and then powering up the CLLIONLC01.</li> <li>▶ If the problem persists, check and – if necessary – reload the application.</li> <li>▶ If the problem still persists, replace hardware</li> </ul>
3	Flashing	Although the controller has encountered a problem, the watchdog alarm output has not yet been powered.  If the problem persists, the LED will become lit constantly, see case #2.  The controller performs a warm start.	If it happens only once, the controller has performed a restart  If, however, it happens multiple times, then there is an application or hardware problem (see case #2)

Table 43 CLLIONLC01 alarm LED



## LONWORKS Service LED

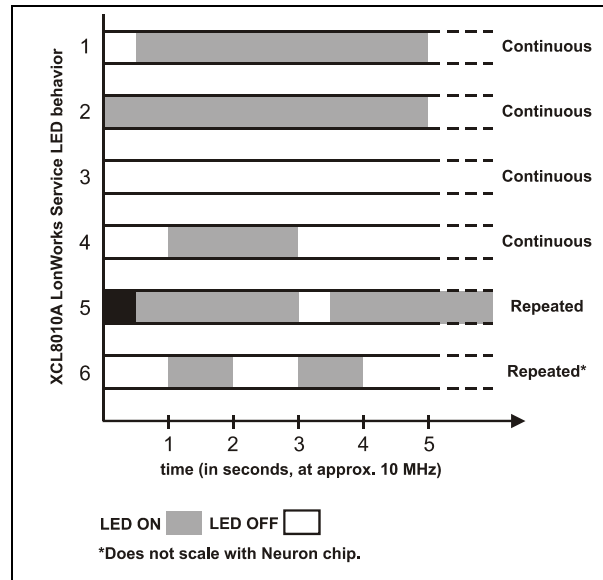

Fig. 57 Flashing pattern of the LONWORKS service LED

The LONWORKS service LED of the controller module displays the following flashing patterns indicating possible failure modes:

case	When can it occur?	Meaning	Remedy
1	Anytime	Node is configured and running normally	No action necessary
2	Power up of controller	Bad node hardware	► Replace hardware
3	Power up of controller	Bad node hardware	► Replace hardware
4	Power up / reset	Node lacks application. May be caused by neuron chip firmware when a mismatch occurs on application checksum	► Using EXCELON, set module to "configured online" ► If the problem persists, the MIP software on LW interface has been erased due to wrong setting performed using ECHELON tool: Replace hardware
5	Anytime	Watchdog timer resets occurring. Possible corrupt EEPROM and bootstrap mode	► Download firmware
6	Anytime	Node is unconfigured but has an application	► Proceed with commissioning

Table 44 CLLIONLC01 LONWORKS service LED

### C-Bus Tx and Rx LEDs

case	C-Bus LEDs	Meaning	Remedy
1	Both LEDs are flashing	If the C-bus is functioning properly, then the CLLIONLC01 Controller is functioning properly	No action necessary
		If the C-bus is not functioning properly, then the termination can be wrong	► Check C-bus termination switch S1 (location: see Fig. 45 on page 32)
2	Both LEDs are OFF	No C-bus communication	► Check C-bus settings
3	Both LEDs are flashing synchronously	No C-bus communication	► Check C-bus wiring

Table 45 CLLIONLC01 C-Bus Tx and Rx LEDs

### HMI Tx and Rx LEDs

case	HMI LEDs	Meaning	Remedy
1	Both LEDs are flashing	If the HMI Interface is functioning properly, then the CLLIONLC01 Controller is functioning properly	No action necessary
2	Both LEDs are OFF	No HMI Interface communication	► Check HMI Interface connection and proper earthing of connected hardware

Table 46 CLLIONLC01 HMI Tx and Rx LEDs

### Modem Tx and Rx LEDs

case	Modem LEDs	Meaning	Remedy
1	Both LEDs are flashing	If the Modem Interface is functioning properly, then the CLLIONLC01 Controller is functioning properly	No action necessary
2	Both LEDs are OFF	No Modem Interface communication	► Check Modem Interface connection

Table 47 CLLIONLC01 modem Tx and Rx LEDs

## Appendix 1: System Protective Earth Grounding

### LION Systems and SELV

In order to avoid distribution of noise or earth ground potential differences over networks or other connections, the CLLIONLC01 is designed to be in compliance with SELV (Safety Extra-Low Voltage).

Furthermore, SELV offers the greatest possible safety against electrical impact.

To support SELV, all CentralLine external (CRT series) or internal transformers comply with standard EN60742.

Earth grounding is therefore not recommended.

### LION Systems and Standard EN60204-1

However, if compliance with EN60204-1 is required, note the following:

#### General Information about EN60204-1

EN60204-1 defines electrical safety for a complete application/machine including controllers, sensors, actuators and any connected/controlled electrical device.

EN60204-1 requires controllers to be powered by PELV (Protective Extra-Low Voltage) and earth grounding of the secondary side of the used transformers or earth grounding of the system ground.

Earth grounding is prescribed to prevent unexpected start-up of connected rotating/moving machines due to an insulation fault and double earth grounding somewhere in the plant.

The use of an earth leakage monitor is also possible to fulfill PELV if earth grounding is prohibited.

#### When is EN60204-1 Applicable to LION Systems?

- **Safety against electrical impact**  
EN60204-1 is not mandatory; this is because electrical safety is provided by the use of SELV and transformers according to standard EN60742.
- **Safety against unexpected start-up of rotating/moving machines**
  - If the application/plant does not contain machines that can be harmful to the operator due to an unexpected start-up, the standard EN60204-1 is not applicable.

If such machines are encountered, then EN60204-1 must be followed. Grounding is required.

### Earth Grounding of EN60204-1 Applicable Systems

- ▶ If system protective earth grounding is planned, use a cable as short as possible for grounding: min. 1.5 mm<sup>2</sup> (16 AWG).
- ▶ For connection details, refer to the following examples.

#### Power Supply and Earthing of LION and Panel Bus I/O Modules with Multiple Controllers

Connecting a single transformer with multiple CLLIONLC01 Controllers earth-grounded as per EN60204-1

- ▶ Connect earth ground to terminal 2 of the CLLIONLC01 Controllers

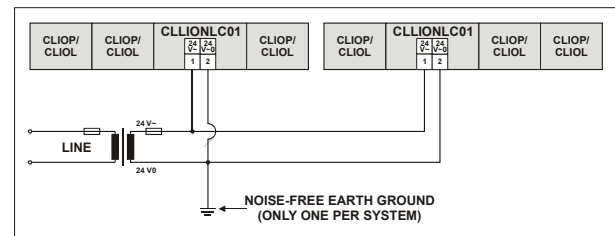

Fig. 58 Connecting and earth grounding multiple CLLIONLC01 Controllers (single transformer)

### Power Supply and Earthing of LION with Multiple Controllers

Connecting a LION System together with other controllers earth-grounded as per EN60204-1

- NOTE:** Use a noise-free earth ground inside the cabinet.
  - NOTE:** Use one star-point to split power for controllers and field devices.
  - NOTE:** If the transformer is used for several controllers, each controller ground has to be wired separately to the star-point.
  - NOTE:** If a field device that prohibits earth grounding is connected to the system ground, an isolation monitoring device must be used instead of earth grounding.
  - NOTE:** If the field device transformer is physically far away from the controller, earth grounding must still be performed for the controller.
- Connect earth ground to the respective terminal of the controllers, see figure below.

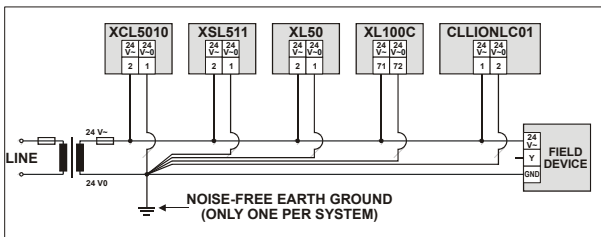

Fig. 59 Connecting and earth grounding mixed controllers (single transformer)

### NOTICE

#### Equipment damage!

Terminals 1 and 2 are assigned differently on the XCL5010 and CLLIONLC01 Controllers.

- Make sure that earth ground is connected to the correct terminal according to Fig. 59 and the respective connection diagrams.

The XL40, XL50, XL100C, Distributed IO, Smart IO, and the LION System can share one transformer.

The XC5010C Controller always requires its own transformer.

If EN60204-1 is applicable for the given type of controller, the system ground has the same potential as one terminal of the power supply.

### LION and Multiple Controllers, Connected by C-Bus

Connecting a C-Bus with controllers earth-grounded as per EN60204-1

- NOTE:** Use a noise-free earth ground inside the cabinet.
- NOTE:** Do not use the controller terminals which are normally used for C-Bus shield connection.
- NOTE:** Be sure to wire the shield only once per bus connection to the earth ground; this is to prevent any current draw over the shield.
- NOTE:** A permanent earth ground potential difference of more than 24 VAC may destroy the related controllers.

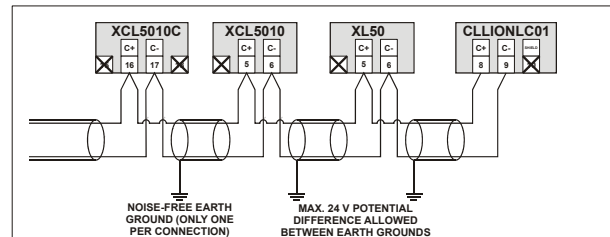

Fig. 60 Connecting C-Bus with multiple controllers earth-grounded as per EN60204-1

If a system ground of the controller is connected to the earth ground, the available terminals for shielding the C-Bus must not be used. Instead, the C-Bus shield must be connected to the earth ground, but only once per bus connection.

## Appendix 2: Remote Communications

For remote communications with up to three centrals, a modem or ISDN terminal adapter can be connected directly to the modem interface of the CLLIONLC01.

**NOTE:** Remote communication via modem or ISDN terminal adapter requires firmware version V2.1.0 or higher.

**NOTE:** XBSi building supervisors are not supported for remote communication.

### Approved Modems

For information on modems approved for use with the LION System, please refer to the “Frequently Asked Questions and Troubleshooting” document available via the Honeywell Technical Assistance Center (TAC) or, for Honeywell employees, on the Intranet under:

<http://web.ge51.honeywell.de/tac>

- ▶ Go there, and enter the catchword "modemfaq" in the search field.

### Modem or ISDN Terminal Adapter Connection

The modem interface of the CLLIONLC01 accepts a standard modem cable with a female 9-pin connector.

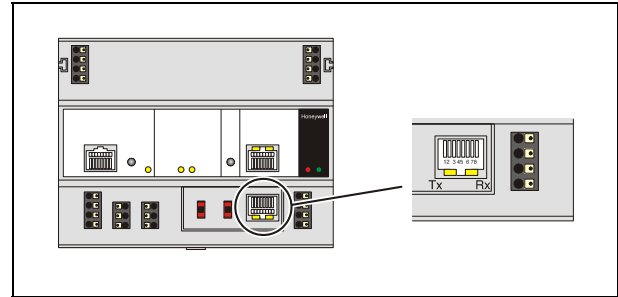

Fig. 61 Modem interface

- ▶ Connect the cable that is supplied with the modem/ISDN terminal adapter to the modem interface of the CLLIONLC01 Controller.

### Modem Requirements

A “Frequently Asked Questions and Troubleshooting” document is available via the Honeywell Technical Assistance Center (TAC) or, for Honeywell employees, on the Intranet under:

<http://web.ge51.honeywell.de/tac>

- ▶ Go there, and enter the catchword "modemfaq" in the search field.

### Troubleshooting

In case of any problems, the handbook of the modem or ISDN terminal adapter must be consulted.

A “Frequently Asked Questions and Troubleshooting” document is available via the Honeywell Technical Assistance Center (TAC) or, for Honeywell employees, on the Intranet under:

<http://web.ge51.honeywell.de/tac>

- ▶ Go there, and enter the catchword "modemfaq" in the search field.

## Appendix 3: Sensor Characteristics

**NOTE:** The following sensor characteristics do not include failures due to:

- sensor failures;
- wiring resistance or wiring failures;
- Misreadings due to a meter connected to measure resistance or voltage at the input.

### BALCO 500

Temp. [°C]	Resistance [Ω]	Terminal voltage [V]
-30.0	397	0.157
-29.0	399	0.158
-28.0	401	0.158
-27.0	403	0.159
-26.0	404	0.160
-25.0	406	0.160
-24.0	408	0.161
-23.0	410	0.162
-22.0	412	0.163
-21.0	413	0.163
-20.0	415	0.164
-19.0	417	0.165
-18.0	419	0.165
-17.0	421	0.166
-16.0	423	0.167
-15.0	425	0.168
-14.0	426	0.168
-13.0	428	0.169
-12.0	430	0.170
-11.0	432	0.171
-10.0	434	0.171
-9.0	436	0.172
-8.0	438	0.173
-7.0	440	0.174
-6.0	442	0.174
-5.0	444	0.175
-4.0	445	0.176
-3.0	447	0.176
-2.0	449	0.177
-1.0	451	0.178
0.0	453	0.179
1.0	455	0.179
2.0	457	0.180
3.0	459	0.181
4.0	461	0.182
5.0	463	0.183
6.0	465	0.183
7.0	467	0.184
8.0	469	0.185
9.0	471	0.186

Temp. [°C]	Resistance [Ω]	Terminal voltage [V]
10.0	473	0.186
11.0	475	0.187
12.0	477	0.188
13.0	479	0.189
14.0	481	0.190
15.0	483	0.190
16.0	485	0.191
17.0	487	0.192
18.0	489	0.193
19.0	491	0.193
20.0	493	0.194
21.0	495	0.195
22.0	497	0.196
23.0	499	0.196
24.0	501	0.197
25.0	503	0.198
26.0	506	0.199
27.0	508	0.200
28.0	510	0.201
29.0	512	0.201
30.0	514	0.202
31.0	516	0.203
32.0	518	0.204
33.0	520	0.205
34.0	522	0.205
35.0	524	0.206
36.0	527	0.207
37.0	529	0.208
38.0	531	0.209
39.0	533	0.210
40.0	535	0.210
41.0	537	0.211
42.0	539	0.212
43.0	542	0.213
44.0	544	0.214
45.0	546	0.215
46.0	548	0.215
47.0	550	0.216
48.0	553	0.217
49.0	555	0.218

Temp. [°C]	Resistance [Ω]	Terminal voltage [V]
50.0	557	0.219
51.0	559	0.220
52.0	561	0.220
53.0	564	0.221
54.0	566	0.222
55.0	568	0.223
56.0	570	0.224
57.0	572	0.225
58.0	575	0.226
59.0	577	0.226
60.0	579	0.227
61.0	581	0.228
62.0	584	0.229
63.0	586	0.230
64.0	588	0.231
65.0	590	0.231
66.0	593	0.233
67.0	595	0.233
68.0	597	0.234
69.0	600	0.235
70.0	602	0.236
71.0	604	0.237
72.0	607	0.238
73.0	609	0.239
74.0	611	0.240
75.0	614	0.241
76.0	616	0.241
77.0	618	0.242
78.0	621	0.243
79.0	623	0.244
80.0	625	0.245
81.0	628	0.246
82.0	630	0.247
83.0	632	0.248
84.0	635	0.249
85.0	637	0.249
86.0	639	0.250
87.0	642	0.251
88.0	644	0.252
89.0	647	0.253

Temp. [°C]	Resistance [Ω]	Terminal voltage [V]
90.0	649	0.254
91.0	651	0.255
92.0	654	0.256
93.0	656	0.257
94.0	659	0.258
95.0	661	0.259
96.0	664	0.260
97.0	666	0.261
98.0	668	0.261
99.0	671	0.262
100.0	673	0.263
101.0	676	0.264
102.0	678	0.265
103.0	681	0.266
104.0	683	0.267
105.0	686	0.268
106.0	688	0.269
107.0	691	0.270
108.0	693	0.271
109.0	696	0.272
110.0	698	0.273
111.0	701	0.274
112.0	703	0.275
113.0	706	0.276
114.0	708	0.276
115.0	711	0.278
116.0	713	0.278
117.0	716	0.280
118.0	718	0.280
119.0	721	0.281
120.0	724	0.283

**NTC 20 k $\Omega$** 

Temp. [°C]	Resistance [k $\Omega$ ]	Terminal voltage [V]
-50.0	1659	8.78
-49.0	1541	8.77
-48.0	1432	8.76
-47.0	1331	8.75
-46.0	1239	8.74
-45.0	1153	8.72
-44.0	1073	8.71
-43.0	1000	8.70
-42.0	932	8.69
-41.0	869	8.67
-40.0	811	8.66
-39.0	757	8.64
-38.0	706	8.62
-37.0	660	8.60
-36.0	617	8.58
-35.0	577	8.56
-34.0	539	8.54
-33.0	505	8.52
-32.0	473	8.49
-31.0	443	8.47
-30.0	415	8.44
-29.0	389	8.41
-28.0	364	8.38
-27.0	342	8.35
-26.0	321	8.32
-25.0	301	8.28
-24.0	283	8.25
-23.0	266	8.21
-22.0	250	8.17
-21.0	235	8.13
-20.0	221	8.08
-19.0	208	8.04
-18.0	196	7.99
-17.0	184	7.94
-16.0	174	7.89
-15.0	164	7.83
-14.0	154	7.78
-13.0	146	7.72
-12.0	137	7.66
-11.0	130	7.60
-10.0	122	7.53
-9.0	116	7.46
-8.0	109	7.39
-7.0	103	7.32
-6.0	97.6	7.25
-5.0	92.3	7.17
-4.0	87.3	7.09
-3.0	82.6	7.01
-2.0	78.2	6.93
-1.0	74.1	6.85
0.0	70.2	6.76
1.0	66.5	6.67
2.0	63.0	6.58
3.0	59.8	6.49
4.0	56.7	6.40

Temp. [°C]	Resistance [k $\Omega$ ]	Terminal voltage [V]
5.0	53.8	6.30
6.0	51.1	6.20
7.0	48.5	6.10
8.0	46.0	6.00
9.0	43.7	5.90
10.0	41.6	5.80
11.0	39.5	5.70
12.0	37.6	5.59
13.0	35.7	5.49
14.0	34.0	5.38
15.0	32.3	5.28
16.0	30.8	5.17
17.0	29.3	5.07
18.0	27.9	4.96
19.0	26.6	4.85
20.0	25.3	4.75
21.0	24.2	4.64
22.0	23.0	4.53
23.0	22.0	4.43
24.0	21.0	4.32
25.0	20.0	4.22
26.0	19.1	4.12
27.0	18.2	4.01
28.0	17.4	3.91
29.0	16.6	3.81
30.0	15.9	3.71
31.0	15.2	3.62
32.0	14.5	3.52
33.0	13.9	3.43
34.0	13.3	3.33
35.0	12.7	3.24
36.0	12.1	3.15
37.0	11.6	3.06
38.0	11.1	2.97
39.0	10.7	2.89
40.0	10.2	2.81
41.0	9.78	2.72
42.0	9.37	2.64
43.0	8.98	2.57
44.0	8.61	2.49
45.0	8.26	2.42
46.0	7.92	2.34
47.0	7.60	2.27
48.0	7.29	2.20
49.0	7.00	2.14
50.0	6.72	2.07
51.0	6.45	2.01
52.0	6.19	1.94
53.0	5.95	1.88
54.0	5.72	1.82
55.0	5.49	1.77
56.0	5.28	1.71
57.0	5.08	1.66
58.0	4.88	1.61
59.0	4.69	1.56

Temp. [°C]	Resistance [k $\Omega$ ]	Terminal voltage [V]
60.0	4.52	1.51
61.0	4.35	1.46
62.0	4.18	1.41
63.0	4.03	1.37
64.0	3.88	1.32
65.0	3.73	1.28
66.0	3.59	1.24
67.0	3.46	1.20
68.0	3.34	1.16
69.0	3.21	1.13
70.0	3.10	1.09
71.0	2.99	1.06
72.0	2.88	1.02
73.0	2.78	0.991
74.0	2.68	0.960
75.0	2.58	0.929
76.0	2.49	0.900
77.0	2.41	0.872
78.0	2.32	0.844
79.0	2.24	0.818
80.0	2.17	0.792
81.0	2.09	0.767
82.0	2.02	0.744
83.0	1.95	0.720
84.0	1.89	0.698
85.0	1.82	0.676
86.0	1.76	0.655
87.0	1.70	0.635
88.0	1.65	0.616
89.0	1.59	0.597
90.0	1.54	0.578
91.0	1.49	0.561
92.0	1.44	0.544
93.0	1.40	0.527
94.0	1.35	0.511
95.0	1.31	0.496
96.0	1.27	0.481
97.0	1.23	0.466
98.0	1.19	0.452
99.0	1.15	0.439
100.0	1.11	0.425
101.0	1.08	0.413
102.0	1.05	0.401
103.0	1.01	0.389
104.0	0.98	0.378
105.0	0.95	0.367
106.0	0.92	0.356
107.0	0.90	0.346
108.0	0.87	0.336
109.0	0.84	0.326
110.0	0.82	0.317
111.0	0.79	0.308
112.0	0.77	0.299
113.0	0.75	0.290
114.0	0.73	0.282

Temp. [°C]	Resistance [k $\Omega$ ]	Terminal voltage [V]
115.0	0.70	0.274
116.0	0.68	0.266
117.0	0.66	0.259
118.0	0.64	0.252
119.0	0.63	0.245
120.0	0.61	0.238
121.0	0.59	0.231
122.0	0.57	0.225
123.0	0.56	0.219
124.0	0.54	0.213
125.0	0.53	0.207
126.0	0.51	0.201
127.0	0.50	0.196
128.0	0.49	0.191
129.0	0.47	0.186
130.0	0.46	0.181
131.0	0.45	0.176
132.0	0.43	0.171
133.0	0.42	0.167
134.0	0.41	0.162
135.0	0.40	0.158
136.0	0.39	0.154
137.0	0.38	0.150
138.0	0.37	0.146
139.0	0.36	0.142
140.0	0.35	0.139
141.0	0.34	0.135
142.0	0.33	0.132
143.0	0.32	0.128
144.0	0.32	0.125
145.0	0.31	0.122
146.0	0.30	0.119
147.0	0.29	0.116
148.0	0.29	0.113
149.0	0.28	0.110
150.0	0.27	0.107

## PT 1000

Temp. [°C]	Resistance [Ω]	Terminal voltage [V]
-50.0	803	0.312
-49.0	807	0.314
-48.0	811	0.315
-47.0	815	0.317
-46.0	819	0.318
-45.0	823	0.320
-44.0	827	0.321
-43.0	831	0.323
-42.0	835	0.324
-41.0	839	0.326
-40.0	843	0.327
-39.0	847	0.329
-38.0	851	0.330
-37.0	855	0.332
-36.0	859	0.333
-35.0	862	0.335
-34.0	866	0.336
-33.0	870	0.338
-32.0	874	0.339
-31.0	878	0.341
-30.0	882	0.342
-29.0	886	0.344
-28.0	890	0.345
-27.0	894	0.347
-26.0	898	0.348
-25.0	902	0.350
-24.0	906	0.351
-23.0	910	0.353
-22.0	914	0.354
-21.0	918	0.356
-20.0	922	0.357
-19.0	926	0.359
-18.0	929	0.360
-17.0	933	0.361
-16.0	937	0.363
-15.0	941	0.364
-14.0	945	0.366
-13.0	949	0.367
-12.0	953	0.369
-11.0	957	0.370
-10.0	961	0.372
-9.0	965	0.373
-8.0	969	0.375
-7.0	973	0.376
-6.0	977	0.378
-5.0	980	0.379
-4.0	984	0.380
-3.0	988	0.382
-2.0	992	0.383
-1.0	996	0.385
0.0	1000	0.386
1.0	1004	0.388
2.0	1008	0.389
3.0	1012	0.391
4.0	1016	0.392
5.0	1020	0.394
6.0	1023	0.395
7.0	1027	0.396
8.0	1031	0.398
9.0	1035	0.399

Temp. [°C]	Resistance [Ω]	Terminal voltage [V]
10.0	1039	0.401
11.0	1043	0.402
12.0	1047	0.404
13.0	1051	0.405
14.0	1055	0.406
15.0	1058	0.408
16.0	1062	0.409
17.0	1066	0.411
18.0	1070	0.412
19.0	1074	0.413
20.0	1078	0.415
21.0	1082	0.416
22.0	1086	0.418
23.0	1090	0.419
24.0	1093	0.420
25.0	1097	0.422
26.0	1101	0.423
27.0	1105	0.425
28.0	1109	0.426
29.0	1113	0.428
30.0	1117	0.429
31.0	1121	0.431
32.0	1124	0.432
33.0	1128	0.433
34.0	1132	0.435
35.0	1136	0.436
36.0	1140	0.438
37.0	1144	0.439
38.0	1148	0.441
39.0	1152	0.442
40.0	1155	0.443
41.0	1159	0.445
42.0	1163	0.446
43.0	1167	0.448
44.0	1171	0.449
45.0	1175	0.451
46.0	1179	0.452
47.0	1182	0.453
48.0	1186	0.455
49.0	1190	0.456
50.0	1194	0.458
51.0	1198	0.459
52.0	1202	0.461
53.0	1205	0.462
54.0	1209	0.463
55.0	1213	0.465
56.0	1217	0.466
57.0	1221	0.467
58.0	1225	0.469
59.0	1229	0.470
60.0	1232	0.471
61.0	1236	0.473
62.0	1240	0.474
63.0	1244	0.476
64.0	1248	0.477
65.0	1252	0.479
66.0	1255	0.480
67.0	1259	0.481
68.0	1263	0.483
69.0	1267	0.484

Temp. [°C]	Resistance [Ω]	Terminal voltage [V]
70.0	1271	0.486
71.0	1275	0.487
72.0	1278	0.488
73.0	1282	0.490
74.0	1286	0.491
75.0	1290	0.493
76.0	1294	0.494
77.0	1297	0.495
78.0	1301	0.497
79.0	1305	0.498
80.0	1309	0.499
81.0	1313	0.501
82.0	1317	0.502
83.0	1320	0.503
84.0	1324	0.505
85.0	1328	0.506
86.0	1332	0.508
87.0	1336	0.509
88.0	1339	0.510
89.0	1343	0.512
90.0	1347	0.513
91.0	1351	0.515
92.0	1355	0.516
93.0	1358	0.517
94.0	1362	0.519
95.0	1366	0.520
96.0	1370	0.522
97.0	1374	0.523
98.0	1377	0.524
99.0	1381	0.525
100.0	1385	0.527
101.0	1389	0.528
102.0	1393	0.530
103.0	1396	0.531
104.0	1400	0.532
105.0	1404	0.534
106.0	1408	0.535
107.0	1412	0.537
108.0	1415	0.538
109.0	1419	0.539
110.0	1423	0.541
111.0	1427	0.542
112.0	1430	0.543
113.0	1434	0.545
114.0	1438	0.546
115.0	1442	0.547
116.0	1446	0.549
117.0	1449	0.550
118.0	1453	0.551
119.0	1457	0.553
120.0	1461	0.554
121.0	1464	0.555
122.0	1468	0.557
123.0	1472	0.558
124.0	1476	0.560
125.0	1479	0.561
126.0	1483	0.562
127.0	1487	0.564
128.0	1491	0.565
129.0	1494	0.566

Temp. [°C]	Resistance [Ω]	Terminal voltage [V]
130.0	1498	0.567
131.0	1502	0.569
132.0	1506	0.570
133.0	1510	0.572
134.0	1513	0.573
135.0	1517	0.574
136.0	1521	0.576
137.0	1525	0.577
138.0	1528	0.578
139.0	1532	0.580
140.0	1536	0.581
141.0	1539	0.582
142.0	1543	0.584
143.0	1547	0.585
144.0	1551	0.586
145.0	1554	0.587
146.0	1558	0.589
147.0	1562	0.590
148.0	1566	0.592
149.0	1569	0.593
150.0	1573	0.594
151.0	1577	0.596
152.0	1581	0.597
153.0	1584	0.598
154.0	1588	0.600
155.0	1592	0.601
156.0	1596	0.602
157.0	1599	0.603
158.0	1603	0.605
159.0	1607	0.606
160.0	1610	0.607
161.0	1614	0.609
162.0	1618	0.610
163.0	1622	0.612
164.0	1625	0.613
165.0	1629	0.614
166.0	1633	0.615
167.0	1636	0.617
168.0	1640	0.618
169.0	1644	0.619
170.0	1648	0.621
171.0	1651	0.622
172.0	1655	0.623
173.0	1659	0.625
174.0	1662	0.626
175.0	1666	0.627
176.0	1670	0.629
177.0	1674	0.630
178.0	1677	0.631
179.0	1681	0.632
180.0	1685	0.634
181.0	1688	0.635
182.0	1692	0.636
183.0	1696	0.638
184.0	1699	0.639
185.0	1703	0.640
186.0	1707	0.642
187.0	1711	0.643
188.0	1714	0.644
189.0	1718	0.645



Temp. [°C]	Resistance [Ω]	Terminal voltage [V]
190.0	1722	0.647
191.0	1725	0.648
192.0	1729	0.649
193.0	1733	0.651
194.0	1736	0.652
195.0	1740	0.653
196.0	1744	0.655
197.0	1747	0.656
198.0	1751	0.657
199.0	1755	0.658
200.0	1758	0.659
201.0	1762	0.661
202.0	1766	0.662
203.0	1769	0.663
204.0	1773	0.665
205.0	1777	0.666
206.0	1780	0.667
207.0	1784	0.669
208.0	1788	0.670
209.0	1791	0.671
210.0	1795	0.672
211.0	1799	0.674
212.0	1802	0.675
213.0	1806	0.676
214.0	1810	0.678
215.0	1813	0.679
216.0	1817	0.680
217.0	1821	0.681
218.0	1824	0.683
219.0	1828	0.684
220.0	1832	0.685
221.0	1835	0.686
222.0	1839	0.688
223.0	1843	0.689
224.0	1846	0.690
225.0	1850	0.692
226.0	1854	0.693
227.0	1857	0.694
228.0	1861	0.695
229.0	1865	0.697
230.0	1868	0.698
231.0	1872	0.699
232.0	1875	0.700
233.0	1879	0.702
234.0	1883	0.703
235.0	1886	0.704
236.0	1890	0.705
237.0	1894	0.707
238.0	1897	0.708
239.0	1901	0.709
240.0	1905	0.711
241.0	1908	0.712
242.0	1912	0.713
243.0	1915	0.714
244.0	1919	0.716
245.0	1923	0.717
246.0	1926	0.718
247.0	1930	0.719
248.0	1934	0.721
249.0	1937	0.722

Temp. [°C]	Resistance [Ω]	Terminal voltage [V]
250.0	1941	0.723
251.0	1944	0.724
252.0	1948	0.726
253.0	1952	0.727
254.0	1955	0.728
255.0	1959	0.729
256.0	1962	0.730
257.0	1966	0.732
258.0	1970	0.733
259.0	1973	0.734
260.0	1977	0.736
261.0	1980	0.737
262.0	1984	0.738
263.0	1988	0.739
264.0	1991	0.740
265.0	1995	0.742
266.0	1998	0.743
267.0	2002	0.744
268.0	2006	0.746
269.0	2009	0.747
270.0	2013	0.748
271.0	2016	0.749
272.0	2020	0.750
273.0	2024	0.752
274.0	2027	0.753
275.0	2031	0.754
276.0	2034	0.755
277.0	2038	0.757
278.0	2042	0.758
279.0	2045	0.759
280.0	2049	0.760
281.0	2052	0.761
282.0	2056	0.763
283.0	2060	0.764
284.0	2063	0.765
285.0	2067	0.766
286.0	2070	0.768
287.0	2074	0.769
288.0	2077	0.770
289.0	2081	0.771
290.0	2085	0.773
291.0	2088	0.774
292.0	2092	0.775
293.0	2095	0.776
294.0	2099	0.777
295.0	2102	0.778
296.0	2106	0.780
297.0	2110	0.781
298.0	2113	0.782
299.0	2117	0.784
300.0	2120	0.785
301.0	2124	0.786
302.0	2127	0.787
303.0	2131	0.788
304.0	2134	0.789
305.0	2138	0.791
306.0	2142	0.792
307.0	2145	0.793
308.0	2149	0.794
309.0	2152	0.796

Temp. [°C]	Resistance [Ω]	Terminal voltage [V]
310.0	2156	0.797
311.0	2159	0.798
312.0	2163	0.799
313.0	2166	0.800
314.0	2170	0.802
315.0	2173	0.803
316.0	2177	0.804
317.0	2181	0.805
318.0	2184	0.806
319.0	2188	0.808
320.0	2191	0.809
321.0	2195	0.810
322.0	2198	0.811
323.0	2202	0.812
324.0	2205	0.814
325.0	2209	0.815
326.0	2212	0.816
327.0	2216	0.817
328.0	2219	0.818
329.0	2223	0.820
330.0	2226	0.821
331.0	2230	0.822
332.0	2234	0.823
333.0	2237	0.824
334.0	2241	0.826
335.0	2244	0.827
336.0	2248	0.828
337.0	2251	0.829
338.0	2255	0.830
339.0	2258	0.831
340.0	2262	0.833
341.0	2265	0.834
342.0	2269	0.835
343.0	2272	0.836
344.0	2276	0.838
345.0	2279	0.839
346.0	2283	0.840
347.0	2286	0.841
348.0	2290	0.842
349.0	2293	0.843
350.0	2297	0.845
351.0	2300	0.846
352.0	2304	0.847
353.0	2307	0.848
354.0	2311	0.849
355.0	2314	0.850
356.0	2318	0.852
357.0	2321	0.853
358.0	2325	0.854
359.0	2328	0.855
360.0	2332	0.856
361.0	2335	0.857
362.0	2339	0.859
363.0	2342	0.860
364.0	2346	0.861
365.0	2349	0.862
366.0	2353	0.863
367.0	2356	0.864
368.0	2360	0.866
369.0	2363	0.867

Temp. [°C]	Resistance [Ω]	Terminal voltage [V]
370.0	2367	0.868
371.0	2370	0.869
372.0	2373	0.870
373.0	2377	0.871
374.0	2380	0.872
375.0	2384	0.874
376.0	2387	0.875
377.0	2391	0.876
378.0	2394	0.877
379.0	2398	0.878
380.0	2401	0.879
381.0	2405	0.881
382.0	2408	0.882
383.0	2412	0.883
384.0	2415	0.884
385.0	2419	0.885
386.0	2422	0.886
387.0	2426	0.888
388.0	2429	0.889
389.0	2432	0.890
390.0	2436	0.891
391.0	2439	0.892
392.0	2443	0.893
393.0	2446	0.894
394.0	2450	0.896
395.0	2453	0.897
396.0	2457	0.898
397.0	2460	0.899
398.0	2463	0.900
399.0	2467	0.901
400.0	2470	0.902

## NI1000TK5000

Temp. [°C]	Resistance [Ω]	Terminal voltage [V]
-30	871.7	0.338
-29	875.8	0.340
-28	880	0.341
-27	884.1	0.343
-26	888.3	0.344
-25	892.5	0.346
-24	896.7	0.348
-23	900.8	0.349
-22	905.1	0.351
-21	909.3	0.352
-20	913.5	0.354
-19	917.7	0.355
-18	922	0.357
-17	926.2	0.359
-16	930.5	0.360
-15	934.7	0.362
-14	939	0.363
-13	943.3	0.365
-12	947.6	0.367
-11	951.9	0.368
-10	956.2	0.370
-9	960.6	0.371
-8	964.9	0.373
-7	969.3	0.375
-6	973.6	0.376
-5	978	0.378
-4	982.4	0.380
-3	986.7	0.381
-2	991.2	0.383
-1	995.6	0.384
0	1000	0.386
1	1004.4	0.388
2	1008.9	0.389
3	1013.3	0.391
4	1017.8	0.393
5	1022.3	0.394
6	1026.7	0.396
7	1031.2	0.398
8	1035.8	0.399
9	1040.3	0.401
10	1044.8	0.403
11	1049.3	0.404
12	1053.9	0.406
13	1058.4	0.408
14	1063	0.409
15	1067.6	0.411
16	1072.2	0.413
17	1076.8	0.415

Temp. [°C]	Resistance [Ω]	Terminal voltage [V]
18	1081.4	0.416
19	1086	0.418
20	1090.7	0.420
21	1095.3	0.421
22	1100	0.423
23	1104.6	0.425
24	1109.3	0.427
25	1114	0.428
26	1118.7	0.430
27	1123.4	0.432
28	1128.1	0.433
29	1132.9	0.435
30	1137.6	0.437
31	1142.4	0.439
32	1147.1	0.440
33	1151.9	0.442
34	1156.7	0.444
35	1161.5	0.446
36	1166.3	0.447
37	1171.2	0.449
38	1176	0.451
39	1180.9	0.453
40	1185.7	0.455
41	1190.6	0.456
42	1195.5	0.458
43	1200.4	0.460
44	1205.3	0.462
45	1210.2	0.463
46	1215.1	0.465
47	1220.1	0.467
48	1225	0.469
49	1230	0.471
50	1235	0.473
51	1240	0.474
52	1245	0.476
53	1250	0.478
54	1255	0.480
55	1260.1	0.482
56	1265.1	0.484
57	1270.2	0.485
58	1275.3	0.487
59	1280.3	0.489
60	1285.4	0.491
61	1290.6	0.493
62	1295.7	0.495
63	1300.8	0.496
64	1306	0.498
65	1311.1	0.500

Temp. [°C]	Resistance [Ω]	Terminal voltage [V]
66	1316.3	0.502
67	1321.5	0.504
68	1326.7	0.506
69	1331.9	0.508
70	1337.1	0.510
71	1342.4	0.512
72	1347.6	0.513
73	1352.9	0.515
74	1358.2	0.517
75	1363.5	0.519
76	1368.8	0.521
77	1374.1	0.523
78	1379.4	0.525
79	1384.8	0.527
80	1390.1	0.529
81	1395.5	0.531
82	1400.9	0.533
83	1406.3	0.535
84	1411.7	0.537
85	1417.1	0.538
86	1422.5	0.540
87	1428	0.542
88	1433.4	0.544
89	1438.9	0.546
90	1444.4	0.548
91	1449.9	0.550
92	1455.4	0.552
93	1460.9	0.554
94	1466.5	0.556
95	1472	0.558
96	1477.6	0.560
97	1483.2	0.562
98	1488.8	0.564
99	1494.4	0.566
100	1500	0.568
101	1505.6	0.570
102	1511.3	0.572
103	1517	0.574
104	1522.6	0.576
105	1528.3	0.578
106	1534	0.580
107	1539.7	0.582
108	1545.5	0.584
109	1551.2	0.586
110	1557	0.589
111	1562.8	0.591
112	1568.5	0.593
113	1574.4	0.595

Temp. [°C]	Resistance [Ω]	Terminal voltage [V]
114	1580.2	0.597
115	1586	0.599
116	1591.8	0.601
117	1597.7	0.603
118	1603.6	0.605
119	1609.5	0.607
120	1615.4	0.609
121	1621.3	0.611
122	1627.2	0.613
123	1633.2	0.616
124	1639.1	0.618
125	1645.1	0.620
126	1651.1	0.622
127	1657.1	0.624
128	1663.1	0.626
129	1669.1	0.628
130	1675.2	0.630

## NTC 10 kΩ

Temp. [°C]	Resistance [kΩ]	Terminal voltage [V]
-30	177	7.904
-29	166.35	7.848
-28	156.413	7.790
-27	147.136	7.730
-26	138.47	7.666
-25	130.372	7.601
-24	122.8	7.534
-23	115.718	7.464
-22	109.089	7.392
-21	102.883	7.318
-20	97.073	7.241
-19	91.597	7.161
-18	86.471	7.080
-17	81.667	6.996
-16	77.161	6.910
-15	72.932	6.821
-14	68.962	6.731
-13	65.231	6.639
-12	61.723	6.545
-11	58.424	6.448
-10	55.321	6.351
-9	52.399	6.251
-8	49.648	6.150
-7	47.058	6.047
-6	44.617	5.943
-5	42.317	5.838
-4	40.15	5.732
-3	38.106	5.624
-2	36.18	5.516
-1	34.363	5.408
0	32.65	5.299
1	31.027	5.189
2	29.494	5.079
3	28.047	4.969
4	26.68	4.859
5	25.388	4.750
6	24.166	4.641
7	23.01	4.532
8	21.916	4.423
9	20.88	4.316
10	19.898	4.209
11	18.968	4.103

Temp. [°C]	Resistance [kΩ]	Terminal voltage [V]
12	18.087	3.998
13	17.252	3.894
14	16.46	3.792
15	15.708	3.690
16	14.995	3.591
17	14.319	3.492
18	13.678	3.396
19	13.068	3.300
20	12.49	3.207
21	11.94	3.115
22	11.418	3.025
23	10.921	2.937
24	10.449	2.850
25	10	2.767
26	9.572	2.684
27	9.165	2.603
28	8.777	2.524
29	8.408	2.447
30	8.057	2.372
31	7.722	2.299
32	7.402	2.228
33	7.098	2.159
34	6.808	2.091
35	6.531	2.025
36	6.267	1.962
37	6.015	1.900
38	5.775	1.840
39	5.546	1.781
40	5.327	1.724
41	5.117	1.669
42	4.917	1.616
43	4.726	1.564
44	4.543	1.514
45	4.369	1.465
46	4.202	1.418
47	4.042	1.373
48	3.889	1.329
49	3.743	1.286
50	3.603	1.244
51	3.469	1.204
52	3.34	1.166
53	3.217	1.128

Temp. [°C]	Resistance [kΩ]	Terminal voltage [V]
54	3.099	1.092
55	2.986	1.057
56	2.878	1.023
57	2.774	0.990
58	2.675	0.959
59	2.579	0.928
60	2.488	0.898
61	2.4	0.870
62	2.316	0.842
63	2.235	0.815
64	2.158	0.790
65	2.083	0.765
66	2.011	0.740
67	1.943	0.718
68	1.877	0.695
69	1.813	0.673
70	1.752	0.652
71	1.694	0.632
72	1.637	0.612
73	1.583	0.593
74	1.531	0.575
75	1.481	0.557
76	1.433	0.541
77	1.387	0.524
78	1.342	0.508
79	1.299	0.493
80	1.258	0.478
81	1.218	0.464
82	1.179	0.450
83	1.142	0.436
84	1.107	0.423
85	1.072	0.411
86	1.039	0.399
87	1.007	0.387
88	0.976	0.375
89	0.947	0.365
90	0.918	0.354
91	0.89	0.344
92	0.863	0.334
93	0.838	0.324
94	0.813	0.315
95	0.789	0.306

Temp. [°C]	Resistance [kΩ]	Terminal voltage [V]
96	0.765	0.297
97	0.743	0.289
98	0.721	0.280
99	0.7	0.276
100	0.68	0.265

## PT 3000

Temp. [°C]	Resistance [kΩ]	Terminal voltage [V]
-50	2.823	1.018
-45	2.868	1.033
-40	2.913	1.047
-35	2.957	1.061
-30	3.002	1.076
-25	3.046	1.090
-20	3.090	1.104
-15	3.134	1.118
-10	3.178	1.132
-5	3.222	1.146
0	3.266	1.160
5	3.310	1.173
10	3.353	1.187
15	3.397	1.200
20	3.440	1.214
25	3.484	1.227
30	3.527	1.241
35	3.570	1.254
40	3.613	1.267
45	3.656	1.280
50	3.699	1.293
55	3.742	1.306
60	3.784	1.319
65	3.827	1.332
70	3.869	1.345
75	3.912	1.358
80	3.954	1.370
85	3.996	1.383
90	4.038	1.395
95	4.080	1.408
100	4.122	1.420
105	4.164	1.433
110	4.206	1.445
115	4.247	1.457
120	4.289	1.469
125	4.330	1.481
130	4.371	1.493
135	4.413	1.505
140	4.454	1.517
145	4.495	1.529
150	4.536	1.541



Manufactured for and on behalf of the Environmental and Combustion Controls Division of Honeywell Technologies Sàrl, Rolle, Z.A. La Pièce 16, Switzerland by its Authorized Representative:

Centraline  
Honeywell GmbH  
Böblinger Strasse 17  
71101 Schönaich, Germany  
Phone +49 (0) 7031 637 845  
Fax +49 (0) 7031 637 740  
[info@centraline.com](mailto:info@centraline.com)  
[www.centraline.com](http://www.centraline.com)

Subject to change without notice  
EN1Z-0921GE51 R0315

