

CLCM1C155A, CLCM4C155A Wall Modules

Product Data



MODELS

order no.	description
CLCM1C155A	<ul style="list-style-type: none"> • 0...10 VDC CO₂ sensor output • 0...10 VDC temperature output • CO₂ level LED • Service LED
CLCM4C155A	<ul style="list-style-type: none"> • 0...10 VDC CO₂ sensor output • NTC20kΩ temp. sensor (passive) • Temp. setpoint wheel (rel./abs. scale) • Occupancy bypass button • Auxiliary LED • Service LED

ACCESSORIES

order no.	description
T7460LIMITER	Limiter for the temperature setpoint wheel
T7460LONJACK	LONWORKS or BACnet access module (5-pc. set)

GENERAL

The CLCM1C155A and CLCM4C155A are combined CO₂ / temperature wall modules designed for applications in indoor ventilation and air conditioning systems. In conjunction with the PANTHER, SERVAL, LION, or EAGLE Controllers, they can be used to control the flow of incoming fresh air, thus improving air quality while reducing energy consumption. During high-occupancy periods, fresh air can be supplied to rooms in order to maintain acceptable air quality, while during low-occupancy periods, the unnecessary conditioning of outdoor air can be avoided or reduced.

FEATURES

- Fully compatible with the PANTHER, SERVAL, LION, or EAGLE Controllers.
- CO₂ sensor employing state-of-the-art Non-Dispersion Infrared (NDIR) technology.
- CO₂ measurement range of 0...2000/3000 ppm.
- Self-calibrating: automatic drift correction (ABC algorithm) based on long-term evaluation.

DIMENSIONS

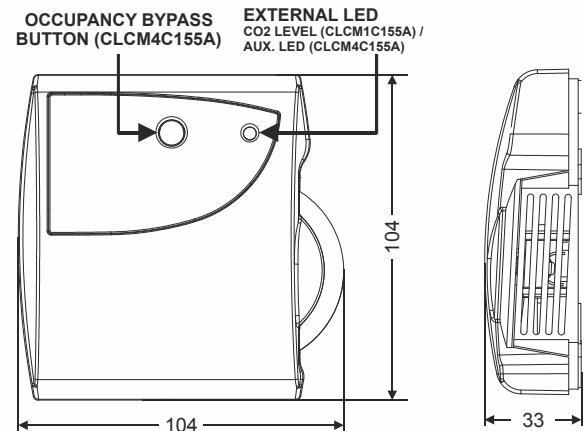

Fig. 1. Dimensions in mm

TECHNICAL DATA

General

Power supply (pins 1+3)	24 VAC \pm 20%; 50/60 Hz or 17...40 VDC; 1.5 VA
Power-up time	\leq 60 sec (incl. self-diagnostics)
Ambient operating limits	0...50 °C, 0...95% rh, non-condensing
Storage limits	-40...+70 °C, 0...95% rh, non-condensing
Sensor life expectancy	> 15 years, maintenance-free

Classification according to EN 60730-1

EN 60730 sub part	EN 60730-2-9
Environmental conditions	For use in residential, commercial, and light-industrial environment
Pollution degree	Class 2
Protection against shock	Class III
Software class	A
Automatic action	Type 1 action

Classification according to EN 60529

Degree of protection provided by enclosures	IP20
---	------

CO2 Measurement

Range	400...2000 / 3000 ppm
Output (pins 1-2)	0...10 VDC for max. 2 mA
Accuracy	factory-calibration \pm 50 ppm or \pm 5% of measurement range
Pressure dependence	+1.6% per kPa deviation from normal pressure of 100 kPa
Response time	90% penetration within 2 min

Active Temperature Sensing (CLCM1C155A, only)

Range	0...50 °C
Output (pins 1+4)	0...10 VDC for max. 2 mA
Accuracy (sensor element)	See Table 1.

Passive Temperature Sensing (CLCM4C155A, only)

Sensor (pins 1+4)	Thermistor NTC20k Ω at 25 °C
Accuracy (sensor element)	See Table 1.

Occupancy Feature (CLCM4C155A, only)

Setpoint potentiometer	relative: -5 K ... +5 K absolute: 12 °C ... 30 °C 1.5 ... 10.5 k Ω
Occupancy bypass	Pushbutton (N.O. to COM; voltage range: 3...24 V, internal resistance < 60 Ω)
Auxiliary LED	Lit > 2.1 VDC or 24 VAC, dark < 1.9 VAC/DC max. 40 VDC, < 1 mA

MOUNTING

WARNING

Risk of electric shock or equipment damage!

- ▶ Do not touch any live parts.
- ▶ Disconnect power supply before making connections.
- ▶ Do not reconnect power until installation is complete.
- ▶ Observe precautions for handling electrostatic sensitive devices.



1. Remove the cover (see Fig. 2).
2. Mount the socket onto the wall approx. 1.5 meters above the floor.
3. Connect the wires to the terminals. Do not connect the power supply until all connections and settings have been correctly completed.
4. Make sure that the setpoint wheel is inserted with the scale range symmetrical (CLCM4C155A). A relative scale (\pm 5 K) or absolute scale (12...30 °C) are available.
5. Remount the cover.

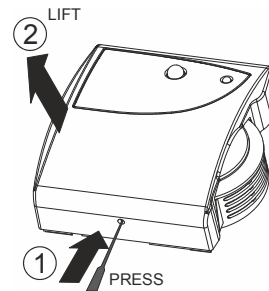

Fig. 2. Removing the cover

T7460-LONJACK

The T7460-LONJACK (ordered separately) is a small board with a 3.5 mm jack. When mounted to the Printed Circuit Board, it provides easy access to LONWORKS / BACnet (the wall module must be already connected to the LONWORKS / BACnet network via a bus cable, in compliance with the max. cable lengths set forth by the LONWORKS / BACnet Guidelines).

Order quantity: set of 5 pieces

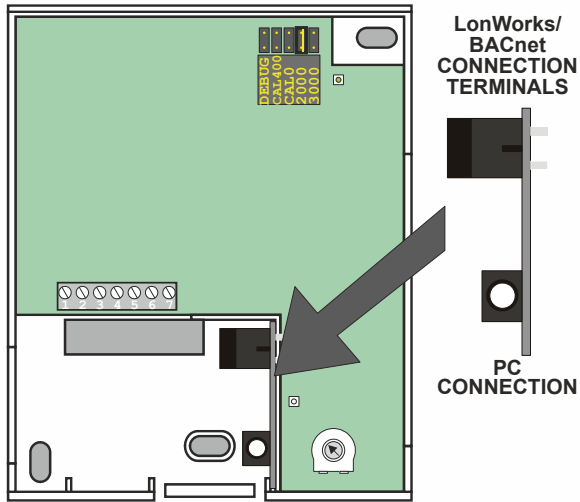

Fig. 3. Mounting the T7460-LONJACK

Wiring

The screw terminals, located on the Printed Circuit Board, are suitable for connecting 0.3 to 1.5 mm² (16...22 AWG) wiring. The terminals assignments of pins 1 through 7 for both models are depicted in Fig. 4 and Fig. 5.

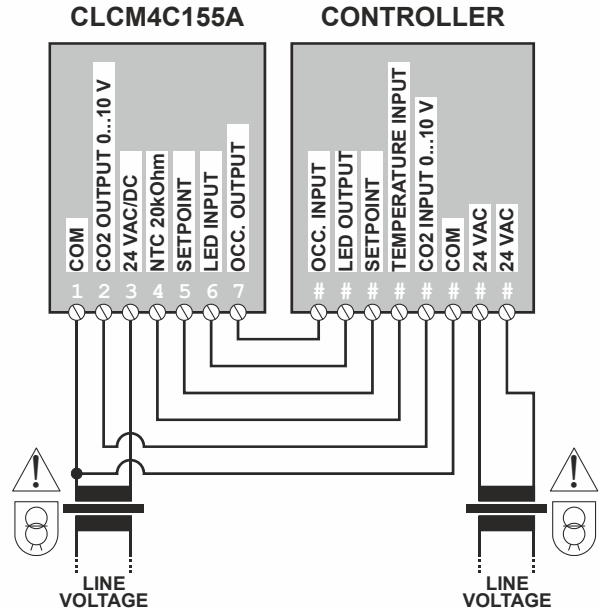

Fig. 5. Wiring CLCM4C155A to controller and separate safety transformer

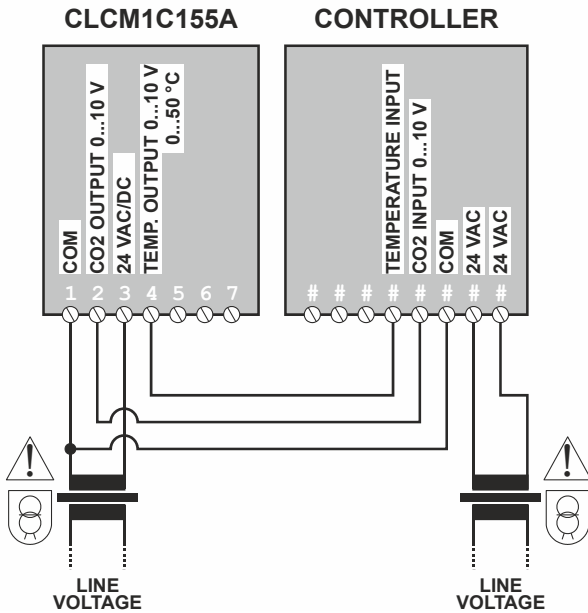

Fig. 4. Wiring CLCM1C155A to controller and separate safety transformer

CONFIGURATION

The wall module can be configured using its configuration jumper and/or its configuration potentiometer.

Configuration Jumper

The wall module's calibration modes can be selected and the CO₂ measuring range extended by repositioning the configuration jumper located on the Printed Circuit Board.

IMPORTANT

Do not change the position of the configuration jumper before first removing power.

In a normal environment, the unit is maintenance-free. Accurate measurement is guaranteed by the built-in ABC self-calibration feature (see below).

Setting Range to 2000 ppm or 3000 ppm

"2000" ppm

When the configuration jumper is set to the factory default position of "2000" ppm (see Fig. 9) – or to any other position **except** "3000" ppm (see Fig. 6) – the CO₂ measuring range is 400...2000 ppm.

"3000" ppm

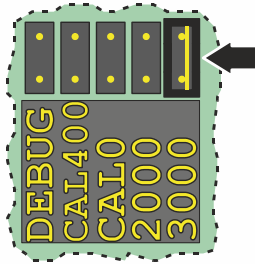

Fig. 6. Jumper set to 3000 ppm

When the configuration jumper is set to position "3000" ppm (see Fig. 6), the CO₂ measuring range will be expanded to 400...3000 ppm.

Quick Calibration Methods

In the event that one cannot wait for ABC to gradually correct measurement errors, it is possible to make use of either one of the following two quick calibration methods:

- Zero Calibration or
- Fast Background Calibration (recommended method).

These quick calibration methods typically takes about 2 minutes.

IMPORTANT

Do not change the position of the configuration jumper before first removing power.

After initiating the desired calibration process by removing power and then repositioning the jumper, restore power and then wait until the calibration process has been completed (see "Behavior of Service LED during Quick Calibration") before again removing power, returning the jumper to the desired range setting (i.e., "2000" or "3000"), and finally restoring power.

Zero Calibration ("CAL0")

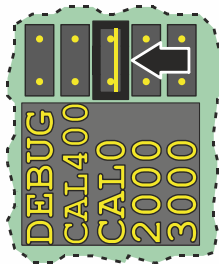

Fig. 7. Jumper set to CAL0

When the configuration jumper is set to position "CAL0" (see Fig. 7), Zero Calibration will be carried out. This is done while testing the wall module with CO₂-free air (e.g., a pure nitrogen atmosphere or air purged of CO₂ using Milk of Lime).

Fast Background Calibration ("CAL400")

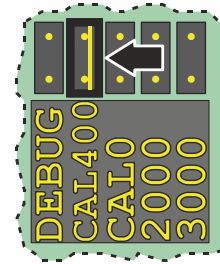

Fig. 8. Jumper set to CAL400

When the configuration jumper is set to position "CAL400" (see Fig. 8), Fast Background Calibration will be carried out. The current level is then set to 400 ppm (= normal expected actual fresh air level) in a single step.

NOTE: Before starting Fast Background Calibration, ventilate the room with fresh outdoor air.

Behavior of Service LED during Quick Calibration

During Zero Calibration or Fast Background Calibration, the Service LED will indicate that the given calibration process is in progress by flashing once per second for 90 sec (sensor warm-up) and then twice per second for 10 sec (sensor calibration). Once the calibration process has been completed, however, the Service LED will then stop flashing and return to normal operational behavior.

NOTE: One possible reason for a failed calibration is if CO₂ levels fluctuate too wildly during calibration; in this event, you should remove and then restore power to the device and perform the calibration again.

ABC

During **ABC (Automatic Baseline Correction)** – which is *ON* by default – any initial (due, e.g., to rough handling during shipping) or subsequent long-term drift will be gradually corrected (i.e., by a max. of 50 ppm per week). This is done by comparing the lowest measured value (over the last 7.5 days) with the expected fresh air level (400 ppm).

When the configuration jumper is set to the factory default position of "2000" ppm or to "3000" ppm, the wall module will operate normally and perform ABC.

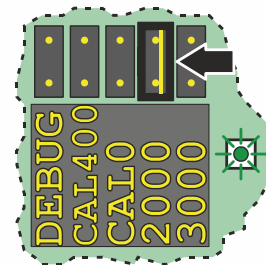

Fig. 9. Default setting (ABC ON = ext. LED flashes GREEN for first 10 s after power restoration)

NOTE: In buildings featuring plastered walls / ceilings or other constructional materials containing quicklime – especially when fresh – unusually low levels of CO₂ (i.e., far below 400 ppm) may prevail, especially in

new, poorly ventilated areas. To prevent sensor malfunctions in such situations, it is recommended that ABC be switched OFF.

Switching ABC OFF and ON
IMPORTANT

Do not change the position of the configuration jumper before first removing power.

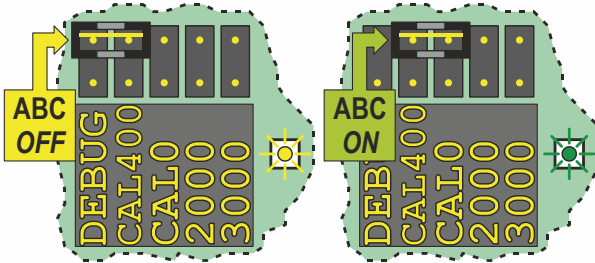

Fig. 10. Switching ABC OFF (left) or ON (right)

ABC can be switched OFF by repositioning the jumper as indicated in the left-hand side of Fig. 10. The external LED will then flash YELLOW briefly and then remain lit YELLOW. This indicates that ABC has finished switching OFF.

NOTE: If ABC is switched OFF, we recommend that you then calibrate the sensor using Zero Calibration or Background Calibration at least once per year to ensure that the CO₂ level readings remain within specifications.

ABC can be switched ON by repositioning the jumper as indicated in the right-hand side of Fig. 10. The external LED will then flash GREEN for the first 10 sec and then remain lit GREEN. This indicates that ABC has finished switching ON.

NOTE: Only after ABC has finished switching ON or OFF should you again remove power, return the jumper to the desired range setting (i.e., "2000" or "3000"), and finally restore power. The given ABC setting (ON or OFF) will then remain in effect even if power is subsequently removed or restored.

"DEBUG"

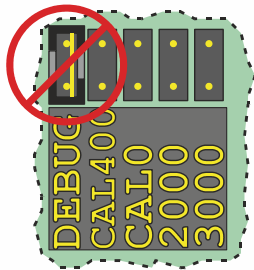

Fig. 11. Do not set jumper set to DEBUG!

DO NOT USE!

Configuration Potentiometer

The wall module features a configuration potentiometer (accessible only after removing the top cover and, in the case of the CLCM4C155A, also the setpoint wheel – see Fig. 2) which can be used to configure the output of terminal 2 (CO₂ level) and (when in the "Relay Output" mode) the "Threshold Level (ppm)".

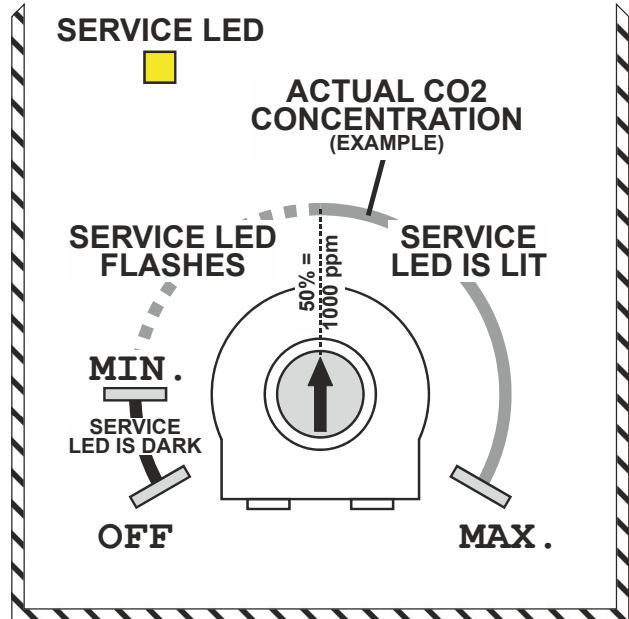

Fig. 12. Configuration potentiometer (e.g., set to 50% = 1000 ppm)

The CO₂ output can operate in two modes:

- To select the "Sensor Output" mode (analog), set the configuration potentiometer to "OFF" (default setting) (see Fig. 12). See also Fig. 13.
- To select the "Relay Output" mode (digital), set the configuration potentiometer to between the "MIN." and "MAX." markers (see Fig. 12). The hysteresis value is permanently set to 100 ppm. See also Fig. 14.

The "Sensor Output" Mode

In the "Sensor Output" mode (analog), the Service LED (see Fig. 12) is always dark.

Further, the CO₂ level indication LED of the CLCM1C155A is lit GREEN when the CO₂ level is below 1000 ppm, and YELLOW when above 1000 ppm.

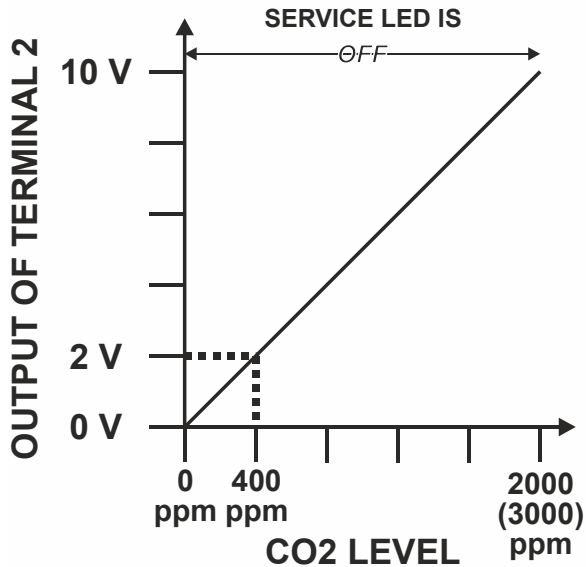

Fig. 13. Sensor output mode (analog)

In the "Sensor Output" mode (analog), terminal 2 delivers an analog output of 0...10 V. You can then configure a measuring range of either 400 to 2000 ppm or 400 to 3000 ppm, depending upon the position of the configuration jumper. Due to ABC calibration to 400 ppm, given measured concentrations below 400 ppm, the output signal will gradually rise to 2 V.

The "Relay Output" Mode

In the "Relay Output" mode (digital), the Service LED (see Fig. 12) will either flash or be lit continuously, thus indicating the actual Threshold Level setting.

Further, the CO₂ level indication LED of the CLCM1C155A is lit GREEN when the CO₂ level is below the threshold, and YELLOW when above the threshold.

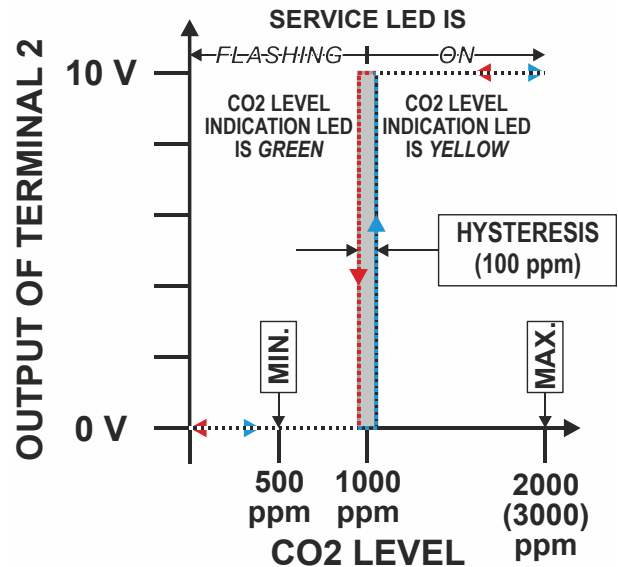

Fig. 14. Relay output mode (digital)

In the "Relay Output" mode (digital), terminal 2 delivers digital output (of 0 / 10 V). You can then configure a "Threshold Level (ppm)" of any value between MIN. = 500 and MAX. = 2000 (or 3000, if configuration jumper is in "3000 ppm") by turning the configuration potentiometer (in the above example, the Threshold Level has been set to 1000 ppm).

Temperature Sensor (CLCM4C155A)

Table 1. Temperature sensor accuracy

ambient temperature	max. error	nominal resistance (Ω)
15.5 °C (60 °F)	±0.29 °C (±0.52 °F)	31543
18.3 °C (65 °F)	±0.27 °C (±0.49 °F)	27511
21.1 °C (70 °F)	±0.27 °C (±0.49 °F)	24047
26.7 °C (80 °F)	±0.27 °C (±0.49 °F)	18490
29.5 °C (85 °F)	±0.29 °C (±0.52 °F)	16264

Electronic offset compensation at 23 °C = 0.5 K.

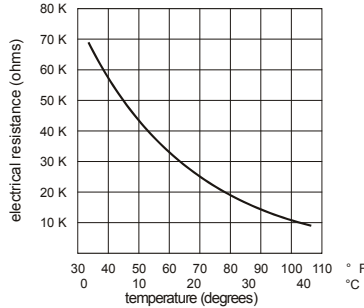

Fig. 15. Temperature vs. resistance for 20 kΩ sensor

Temperature Setpoint Adjustment (CLCM4C155A)

Depending on the type of dial in use on the CLCM4C155A, the corresponding controller must be set for either the relative or the absolute scale. The relation between setpoint and resistance is given in Table 2.

The accuracy of resistance is:

- ±5% in middle position, e.g., 5225 Ω to 5775 Ω
- ±10% in end position, e.g., 9450 Ω to 11550 Ω.

Table 2. Setpoint values versus resistances

relative scale (Kelvin)		absolute scale (°C)	
setpoint	nominal resistance (Ω)	setpoint	nominal resistance (Ω)
-5	9574	12	9958
-4	8759	14	8979
-3	7944	16	8001
-2	7130	18	7022
-1	6315	20	6043
0	5500	22	5065
1	4685	24	4086
2	3870	26	3107
3	3056	28	2129
4	2241	30	1150
5	1426		

Occupancy Bypass Button and Auxiliary LED (CLCM4C155A, only)

NOTE: The functionality of the occupancy bypass button and the corresponding behavior of the auxiliary LED of the CLCM4C155A are dependent upon the programming of the connected controller. Please refer to the controller's technical literature and/or application.

Occupancy Bypass Button

Pressing the occupancy bypass button of the CLCM4C155A connects terminals 1 and 7 (with resultant effects depending upon the programming of the connected controller).

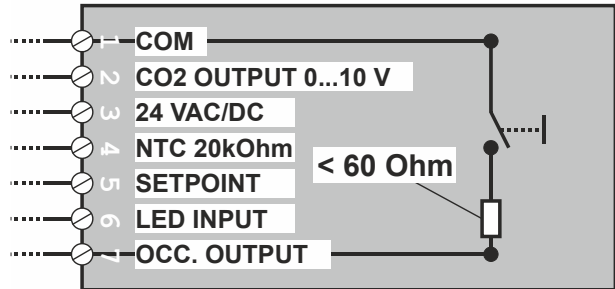

Fig. 16. Occupancy bypass button

LED Behaviors and Meanings**Table 3. LED behaviors and their meanings**

model	service LED	external LED	modes	remarks
1C+4C	1 flash per sec for 90 sec	Controller-dependent	"Sensor Output" (S.O.) and "Relay Output" (R.O.) modes	Calibration warm-up
1C+4C	2 flashes per sec for 10 sec	Controller-dependent	S.O. + R.O.	Calibration in progress
4C	Dark	Controller-dependent	S.O.	Calibration successful
4C	Lit continuously	Controller-dependent	S.O.	Calibration failed
1C	Dark	Green	S.O.	CO ₂ < 1000 ppm
1C	Dark	Yellow	S.O.	CO ₂ > 1000 ppm
1C+4C	Flashing	Green / controller-dependent	R.O.	CO ₂ < threshold
1C+4C	Lit continuously	Yellow / controller-dependent	R.O.	CO ₂ > threshold
1C+4C	--	Flashing green	S.O. + R.O.	ABC ON
1C+4C	--	Flashing yellow	S.O. + R.O.	ABC OFF

Example LED Behaviors**Auxiliary LED Indicating Override**

When the auxiliary LED of the CLCM4C155A has been configured to indicate an override, it can display various different behaviors, e.g.:

- auxiliary LED dark = "no override"
- auxiliary LED lit = "override bypass"
- auxiliary LED flashing once per sec = "override unoccupied"
- auxiliary LED flashing twice per sec = "override standby" or "occupied"
- auxiliary LED flashing four times per sec = wall module receiving wink commands from controller

Auxiliary LED Indicating Occupancy

When the auxiliary LED of the CLCM4C155A has been configured to indicate occupancy, it can display various different behaviors, e.g.:

- auxiliary LED dark = "effective unoccupied"
- auxiliary LED lit = "effective occupied" or "bypass"
- auxiliary LED flashing once per sec = "effective standby"
- auxiliary LED flashing four times per sec = wall module receiving wink commands from controller

Manufactured for and on behalf of the Environmental & Energy Solutions Division of Honeywell Technologies Sàrl, Rolle, Z.A. La Pièce 16, Switzerland by its Authorized Representative:

Centraline
Honeywell GmbH
Böblinger Strasse 17
71101 Schönaich, Germany
Phone +49 (0) 7031 637 845
Fax +49 (0) 7031 637 740
info@centraline.com
www.centraline.com

Subject to change without notice
EN0Z-1008GE51 R0317

