

GENERAL

The CentraLine LONWORKS Bus I/O Modules communicate via the LONWORKS Bus.

These pluggable CentraLine LONWORKS Bus I/O modules consist of a terminal socket and a removable electronic module, allowing the socket to be mounted and wired before the electronic module is installed. All such electronic modules can be swapped out without disrupting the power and bus connections: Simply unplug the "old" and insert the "new" module.



WARNING

Risk of electric shock or equipment damage!

- ▶ Do not touch any live parts in the cabinet.
- ▶ Disconnect the power supply before you start to install the control system. More than one disconnect switch may be required to de-energize the system.
- ▶ Do not reconnect the power supply until you have completed the installation.
- ▶ Unused terminals must be closed (by completely screwing in the terminal screws), thus preventing the accidental touching of "live" parts.

Software updates, configuration, and commissioning are all done automatically by the controller for all LONWORKS Bus I/O Modules.

The LONWORKS Bus I/O Modules may be used with any CPU supporting LONWORKS Bus communication (e.g., the LION, EAGLE, etc.).

FEATURES

- Plug-and-play functionality for easy maintenance.
- Pluggable LONWORKS Bus I/O modules can be exchanged without rewiring. Further, the separate installation of terminal sockets and electronic modules lower risk of damage and theft in the construction phase.
- Fast wiring with state-of-the-art push-in terminals (screw-type terminals also available) and bridge connectors.
- Wide range of sensors supported (NTC20k Ω , NTC10k Ω , PT1000-1/-2, Johnson A99 PTC, NI1000TK5000, PT3000, Balco500, 0/2...10 V, 0/4...20 mA).
- Binary input LEDs of the CentraLine LONWORKS Bus I/O Modules can be configured for status display (off / yellow) or alarm display (green / red) per channel.
- Configurable safety position for outputs, in case of loss of communication with the controller.
- Max. wiring flexibility due to optional accessories like auxiliary terminals and cross-connectors.
- Can be mounted in small installation housings
- Flexible mix of LONWORKS Bus I/O modules covering all your application requirements.

OVERVIEW

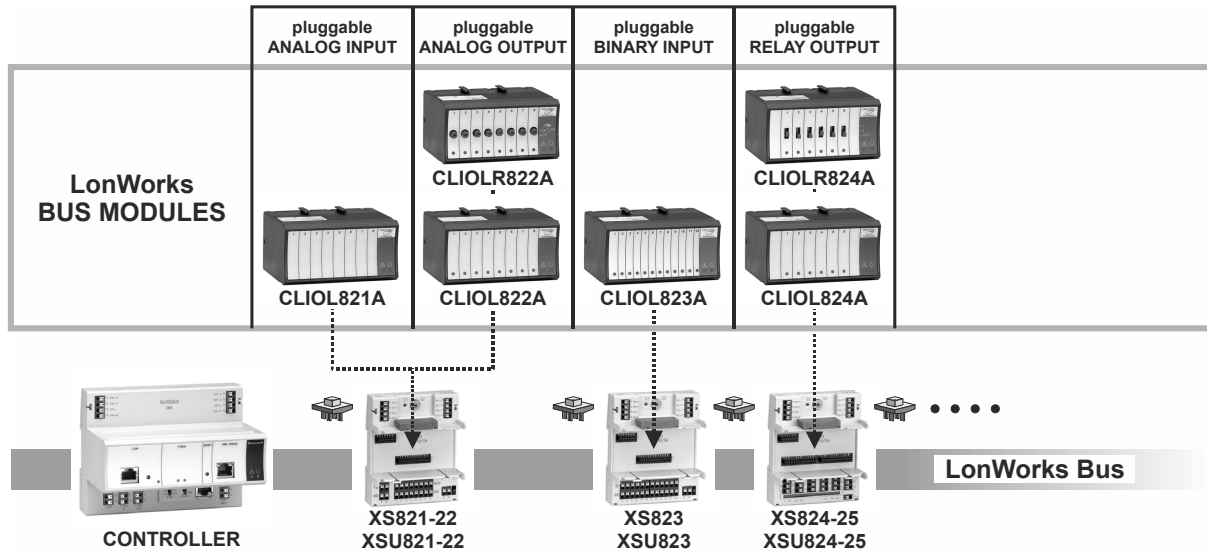



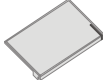

Fig. 1. Overview of CentraLine LonWorks Bus I/O Modules

Table 1. Overview of CentraLine LonWorks Bus I/O Modules

order number	description
LonWorks Bus I/O Modules	
CLIOL821A	LONWORKS Bus Bus Analog Input Module (with 8 analog inputs)
CLIOL822A	LONWORKS Bus Bus Analog Output Module (with 8 analog outputs)
CLIOLR822A	LONWORKS Bus Bus Analog Output Module (with 8 analog outputs and manual overrides)
CLIOL823A	LONWORKS Bus Bus Binary Input Module (with 12 binary inputs)
CLIOL824A	LONWORKS Bus Bus Relay Output Module (with 6 relay outputs)
CLIOLR824A	LONWORKS Bus Bus Relay Output Module (with 6 relay outputs and manual overrides)
Terminal Sockets	
XS821-22	Push-in terminal socket for AI/AO modules (incl. bridge connector, swivel label)
XSU821-22	Screw-type terminal socket for AI/AO modules (incl. bridge connector, swivel label)
XS823	Push-in terminal socket for BI modules (incl. bridge connector, swivel label)
XSU823	Screw-type terminal socket for BI modules (incl. bridge connector, swivel label)
XS824-25	Push-in terminal socket for relay/floating output modules (incl. bridge connector, cross connector, swivel label)
XSU824-25	Screw-type terminal socket for relay/floating output modules (incl. bridge connector, cross connector, swivel label)

Table 2. Overview of auxiliary parts and spare parts

order number	description
 <p>XS814</p>	Ten Auxiliary Terminal Blocks (for distribution of signals/power). Each terminal block includes two groups with seven internally-connected push-in terminals.
 <p>XS815</p>	20 Cross-Connectors for connection of six relay commons. One Cross-Connector is included in the Terminal Socket package.
 <p>XS816</p>	10 Bridge Connectors. One Bridge Connector is included in the Terminal Socket package.
 <p>XAL10</p>	10 Swivel Labels Holders (for attaching the application-specific label printed with CARE / COACH AX / COACH NX). One Swivel Label Holder is included in each Terminal Socket package. NOTE: Phased out.

NOTE: The inputs and outputs of all CentraLine analog and binary I/O modules are protected against short circuit, 24 VAC +20%, and 40 VDC.
 In the case of the relay outputs of other CentraLine I/O modules (i.e., relay output modules, floating output modules, and mixed I/O modules), appropriate fusing must be provided to ensure that permissible load currents are not exceeded. See also sub-section "Features" in section "Relay Output Modules" on pg. 14.

Table 3. Pluggable LonWorks Bus I/O Module specifications

Module	Analog Input	Analog Output	Binary Input	Relay Output
		CLIOL821A	CLIOL822A, CLIOLR822A	CLIOL823A
no. of I/Os	8 analog inputs	8 analog outputs	12 binary inputs requiring a gold contact or open collector	6 relay outputs
characteristics	Linear Graph, 0...10 VDC with pull-up, 0(2)...10 VDC without pull-up <u>NTC20kΩ (-50...+150 °C, default)</u> <u>NTC10kΩ (-30...+100 °C)</u> PT ₁₀₀₀₋₁ (-50...150 °C) PT ₁₀₀₀₋₂ (0...400 °C) Johnson A99 PTC (-40...+120 °C) NI1000TK5000 (-30...+130 °C) PT ₃₀₀₀ (-50...150 °C) BALCO ₅₀₀ (-30...120 °C) Also configurable as: binary inputs <ul style="list-style-type: none"> ▪ Linear graph (0...10 V with pull-up) Features: <ul style="list-style-type: none"> ▪ 16-bit resolution ▪ configurable offset per input ▪ auxiliary voltage: 10 VDC, I_{max} = 5 mA 	0...11 VDC / \pm 1 mA Also configurable as: floating outputs or binary outputs (0 V / 10 V) Features: <ul style="list-style-type: none"> ▪ 8-bit resolution (default) ▪ Safety position (remain, 0%, 50%, 100%) ▪ red LED per output ▪ light intensity follows output level in auto Version with manual override (R): <ul style="list-style-type: none"> ▪ 1 potentiometer per output ▪ auto feedback signal (mode + value) ▪ blinking in manual override position 	static binary input, <u>(default: dry contact)</u> Also configurable as: totalizers (20 Hz) Features: <ul style="list-style-type: none"> ▪ 1 LED per input ▪ Color mode can be set per input to OFF/yellow or green/red using CARE / COACH AX / COACH NX ▪ ON: < 1.6 kΩ to GND or < 2.5 V to GND, OFF: > 90 kΩ to GND or > 4 V to GND 	relay outputs (default) Features: <ul style="list-style-type: none"> ▪ Changeover relays ▪ Voltage: 19...250 VAC, 1...29 VDC, P>50 mW ▪ max. total current: 12 A ▪ current per relay: N.O.: 4(4) A (AC) or 4(1) A (DC), N.C.: 2(1) A (AC) or 4(1) A (DC) ▪ Safety position (remain, 0%, 100%) ▪ yellow LED per output Version with manual override (R): <ul style="list-style-type: none"> ▪ 1 switch per output ▪ auto feedback signal (mode + value) ▪ blinking in manual override position

Manual Overrides as per EN ISO 16484-2:2004

The manual override switches and potentiometers of the output modules support direct operation as per EN ISO 16484-2:2004, section 5.4.3 "Local Priority Override/Indicating Units."

Specifically, the positions of the manual override switches and potentiometers directly control the outputs – independently of the controller and HMI. When a manual override switch or potentiometer is not in its default position ("auto"), the corresponding output LED will blink continuously, and the output module will send a feedback signal with the status "manual override" and the given override position to the controller (which will then also store this information in its alarm memory).

NOTE: When updating the firmware of output modules, their outputs are turned OFF – regardless of the position of their manual override switches and/or potentiometers.

GENERAL FEATURES

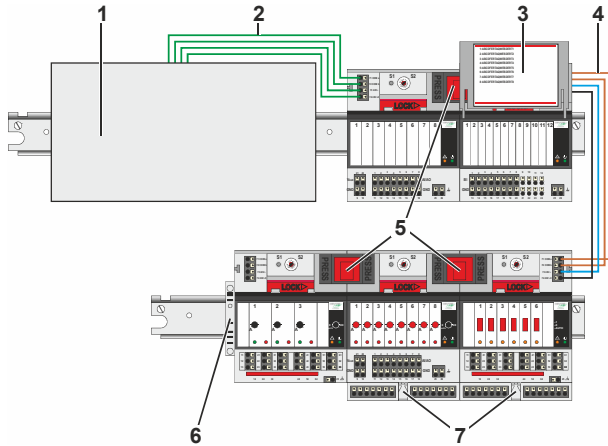

Fig. 2. LonWorks Bus I/O Modules on DIN rails

Legend

- 1 Controller (e.g., LION, EAGLE, HAWK, etc.)
- 2 Cable (power, LONWORKS) connection from controller to LONWORKS Bus I/O Modules
- 3 Swivel label holder
- 4 Cable connection between LONWORKS Bus I/O Modules on separate DIN rails
- 5 Bridge connectors between LONWORKS Bus I/O Modules on same DIN rail
- 6 Stopper (from 3rd-party supplier)
- 7 Auxiliary terminal packages

LEDs

Each CentraLine LONWORKS Bus I/O Module is equipped with:

- one green power LED
- one yellow service LED

Overvoltage Protection

The inputs and outputs of all CentraLine analog and binary I/O modules are protected against short circuit, 24 VAC +20%, and 40 VDC.

In the case of the relay outputs of other CentraLine I/O modules (i.e., relay output modules, floating output modules, and mixed I/O modules), appropriate fusing must be provided to ensure that permissible load currents are not exceeded. See also sub-section "Features" in section "Relay Output Modules" on pg. 14.

Service LED

Each LONWORKS Bus I/O Module is equipped with a yellow service LED (status: yellow/OFF) for easy diagnosis of failures.

LonWorks Service Button

Each LONWORKS Bus I/O Module is equipped with a LONWORKS service button.

Microprocessors

Each LONWORKS I/O Module is equipped with an FTT-10A transceiver (link power-compatible) and can thus be used with any LONWORKS controller.

In addition to the main microprocessor, the LONWORKS Bus I/O Modules also have their own Neuron chip (3120).

System Constraints

Table 4. System constraints

Max. no. of I/O modules (any combination) per controller	depends upon controller type
Max. no. of I/O modules per row	10
Max. current (F1)	4 A
Max. current (F2)	12 A
Max. current (F3)	12 A
Max. row length	3 m
Max. distance between rows	40 m
Min. cross-section of GND (terminal 9) (protected by F2)	1.5 mm ²

Analog Input Module



Fig. 3. CLIO821A LonWorks Bus AI Module (shown with terminal socket)

Legend

- 1 LONWORKS service button S1
- 2 Service LED
- 3 Power LED

NOTE: The hex switch S2 (located next to the LONWORKS service S1) has no function in combination with a LONWORKS Bus I/O module. It is used with Panel Bus I/O modules, only.

The CentraLine LONWORKS Bus Analog Input Module, with 8 analog inputs, is installed with the XS821-22 or XSU821-22 Terminal Socket.

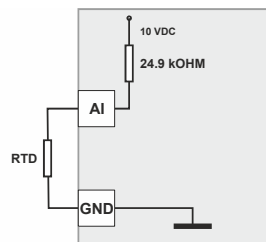

Fig. 4. Analog input low impedance (input circuit for PT1000, Johnson A99 PTC, Balco500, PT3000, NI1000TK5000, slow binary input)

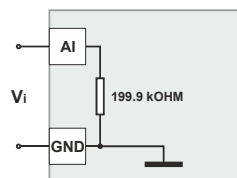

Fig. 5. Analog input high impedance (input circuit for voltage input for active sensors)

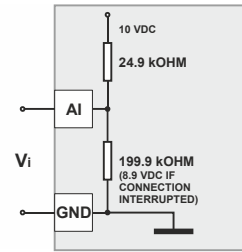

Fig. 6. Analog input impedance setpoint (input circuit for NTC10kΩ, NTC20kΩ, wall module setpoint)

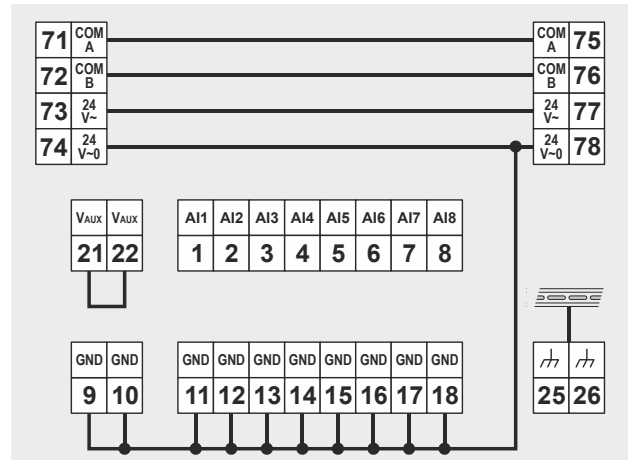

Fig. 7. CentraLine LonWorks Bus Analog Input Module (schematic)

Features

- 0...10 VDC, 2...10 VDC without pull-up
- 0...10 VDC with pull-up (linear graph, e.g., used for wall module connection)
- 0/4...20 mA, needs 499 Ω resistor in parallel
- NTC20kΩ (-50...+150 °C, default)
- NTC10kΩ (-30...+100 °C)
- PT1000-1 (-50...+150 °C)
- PT1000-2 (0...+400 °C)
- NI1000TK5000 (-30...+130 °C)
- PT3000 (-50...+150 °C)
- BALCO500 (-30...+120 °C)
- Binary input
- 16-bit resolution
- Configurable offset per input
- Auxiliary voltage: 10 VDC, $I_{MAX} = 5$ mA
- Sensor failure detection

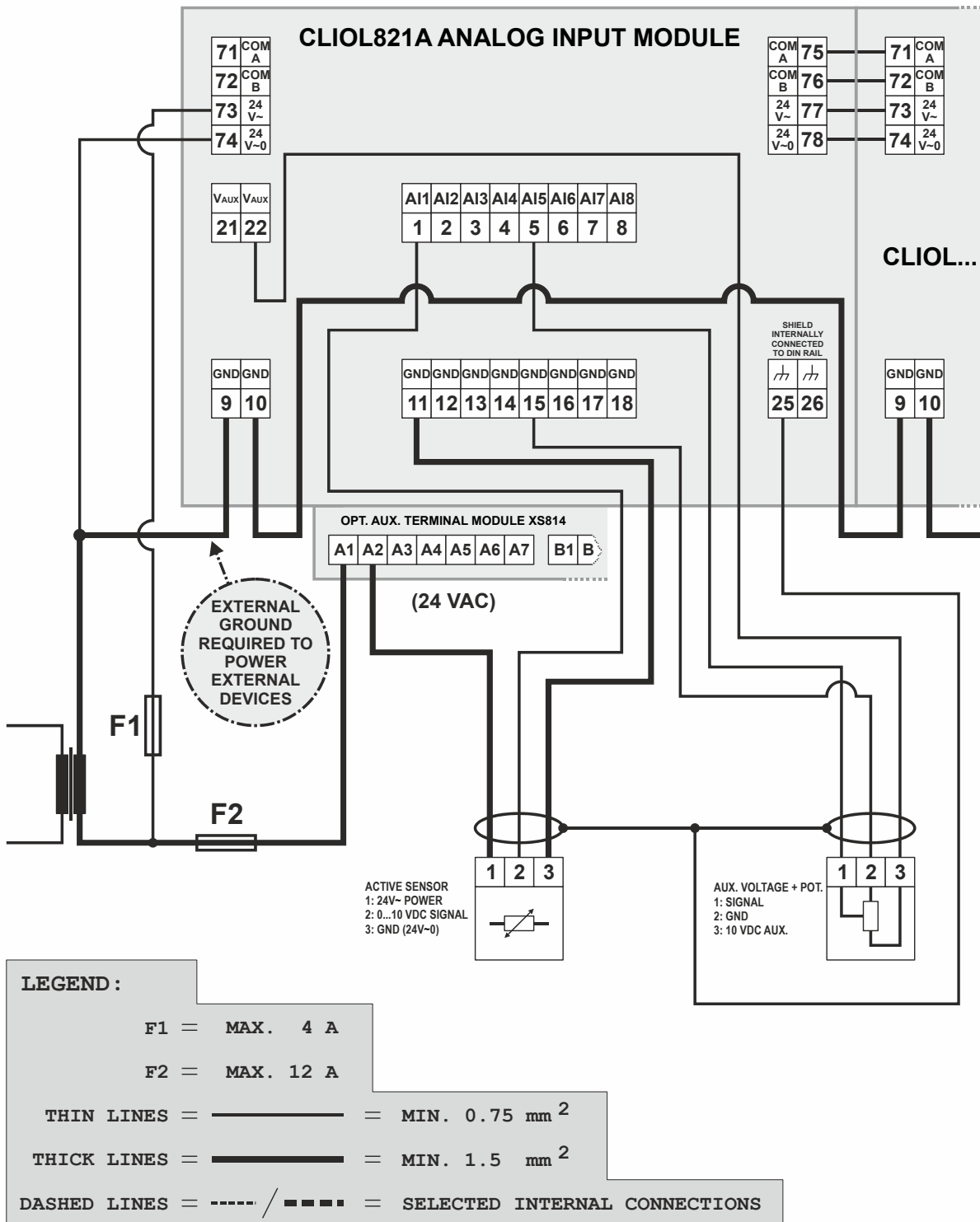

Fig. 8. CLIO821A LonWorks Bus AI Module, wiring example 1: Active sensor and potentiometer

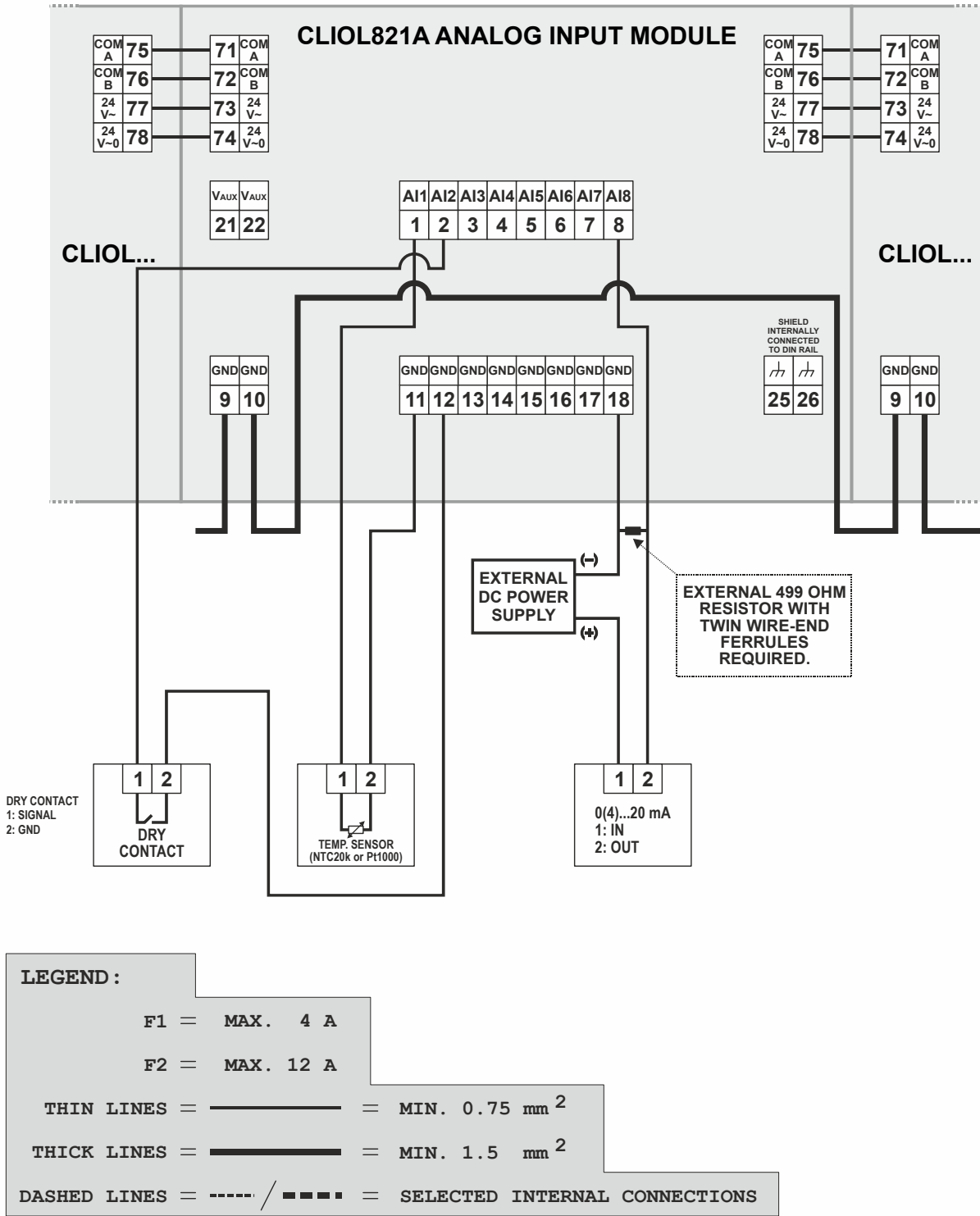

Fig. 9. CLIOP821A LonWorks Bus AI Module, wiring example 2: Passive sensor and 0 (4) ... 20 mA signal

Analog Output Modules

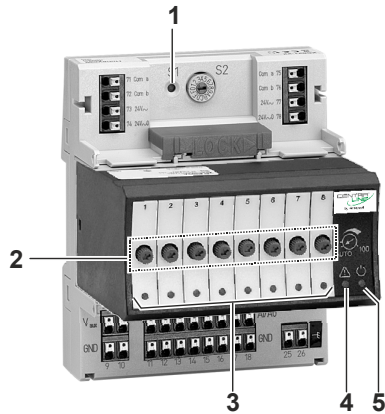

Fig. 10. CLIOPR822A LonWorks Bus AO Module (shown with terminal socket)

Legend

- 1 LONWORKS service button S1
- 2 Manual overrides
- 3 Status LEDs
- 4 Service LED
- 5 Power LED

NOTE: The hex switch S2 (located next to the LONWORKS service S1) has no function in combination with a LONWORKS Bus I/O module. It is used with Panel Bus I/O modules, only.

The CentralLine LONWORKS Bus Analog Output Modules, with 8 analog outputs, are available in the following models:

- CLIOL822A LONWORKS Bus Analog Output Module (without manual overrides)
- CLIOLR822A LONWORKS Bus Analog Output Module (with manual overrides)

They are installed with the XS821-22 or XSU821-22 Terminal Socket.

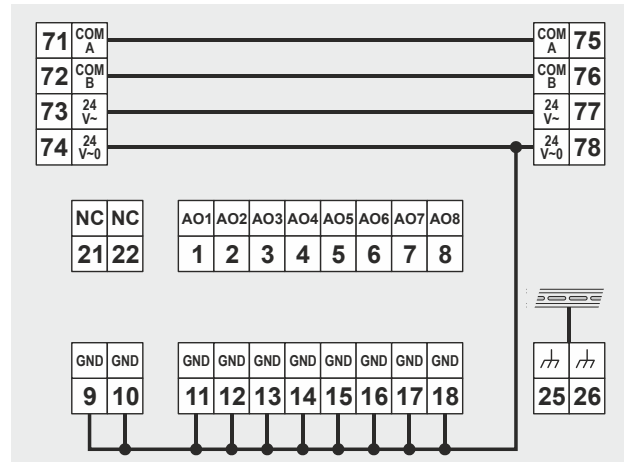

Fig. 11. CentralLine LONWORKS Bus Analog Output Modules (schematic)

Features

- 0...11 VDC, +/-1 mA
- Floating actuator (requires MCD3)
- Binary output (0 V / 10 V)
- red LED per output (brightness according to signal level)
- Optional versions with manual override potentiometers (Auto, 0...100%; LED flashes in override mode)
- Feedback on manual override signal
- 8-bit resolution
- Configurable safety position for outputs in case of communication problems (remain, 0%, 50%, 100%)

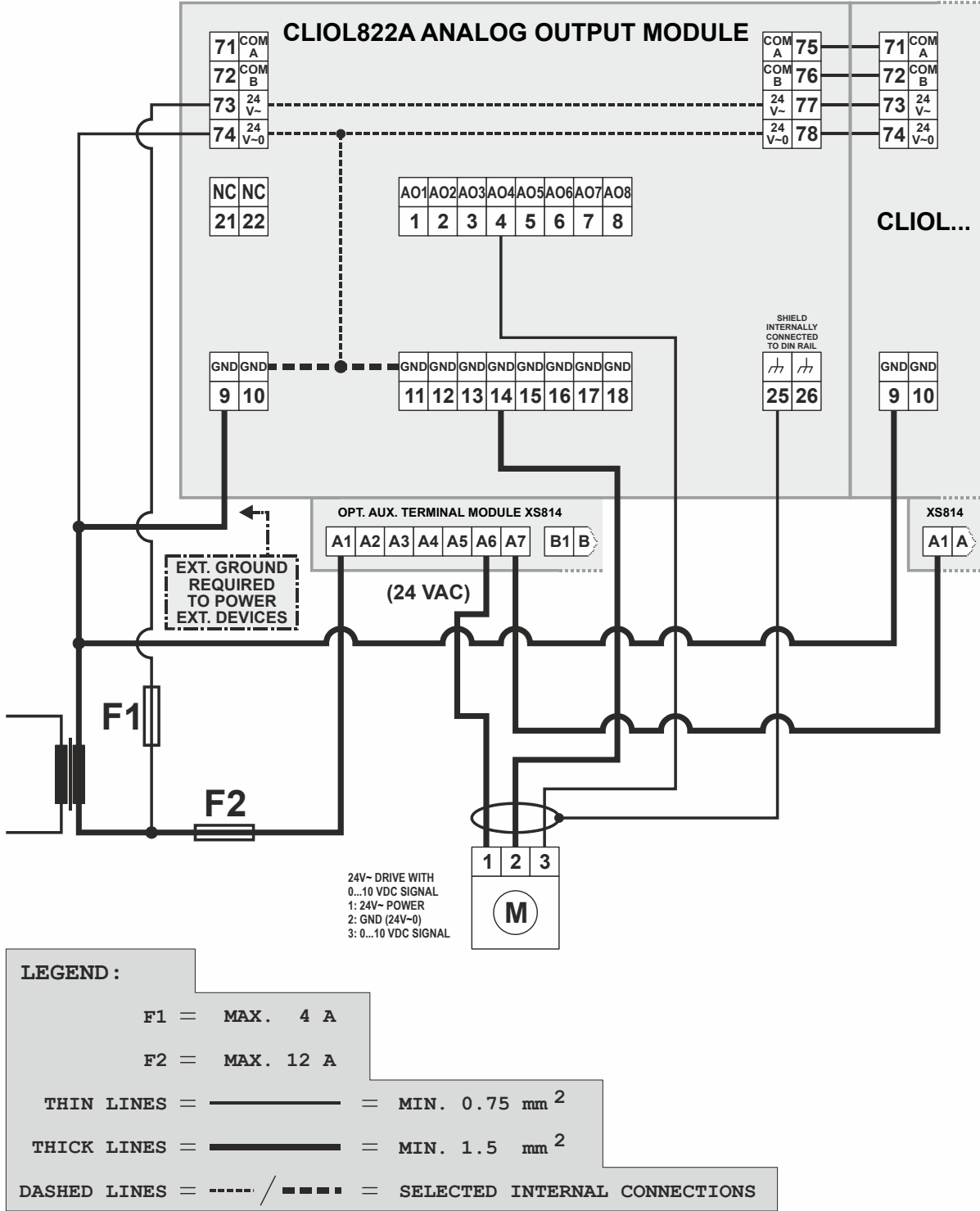

Fig. 12. CLIO822A LonWorks Bus AO Module, wiring example 1: Actuator

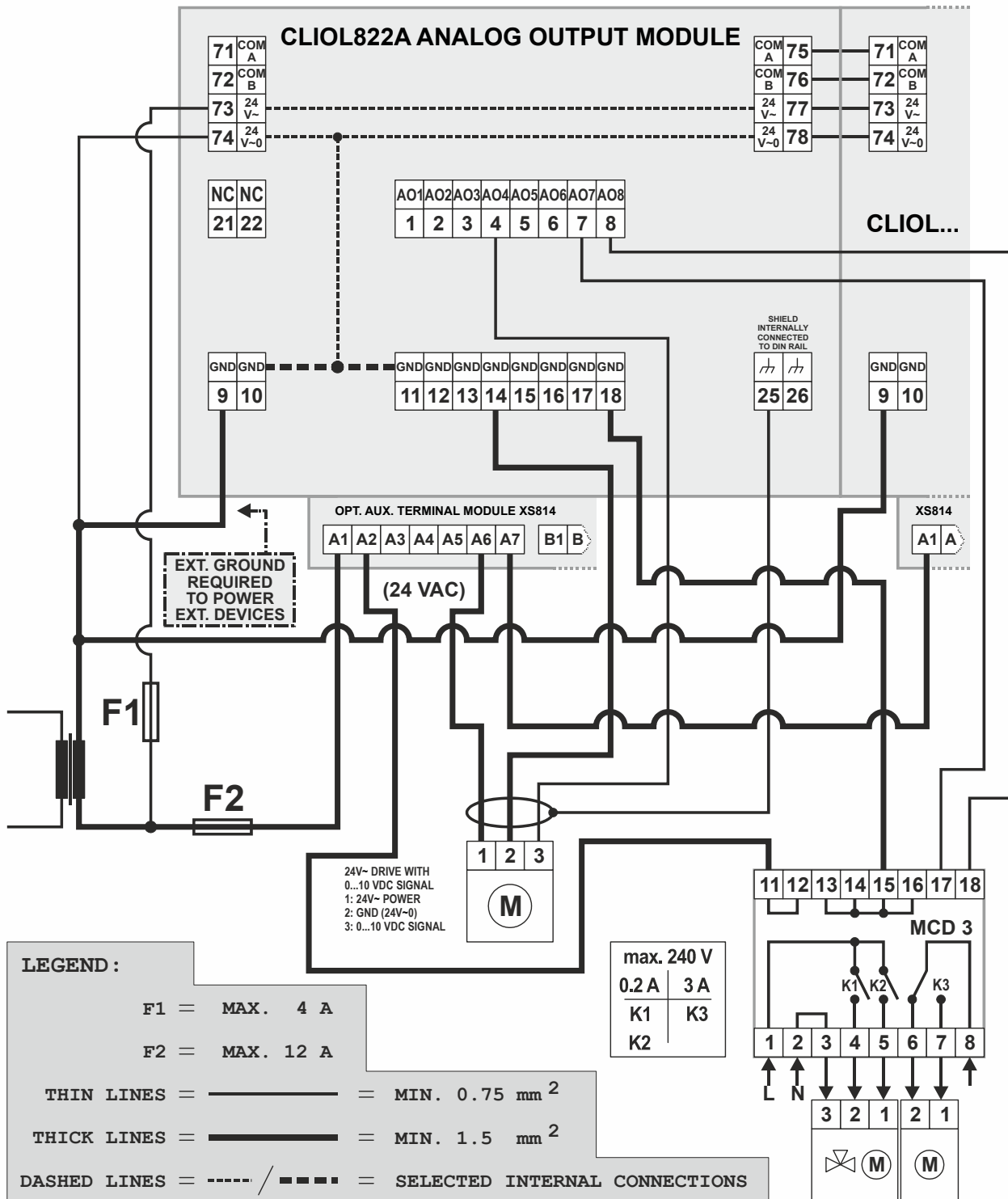

Fig. 13. CLIOL822A LonWorks Bus AO Module, wiring example 2: Relay Module MCD 3

- The relay module facilitates the control of peripheral devices with high load via the analog outputs.
- Input terminal 17 of MCD3 controls changeover contact K3.
- Relay terminal 18 of MCD3 controls the N.O. contacts (floating outputs) K1, K2.

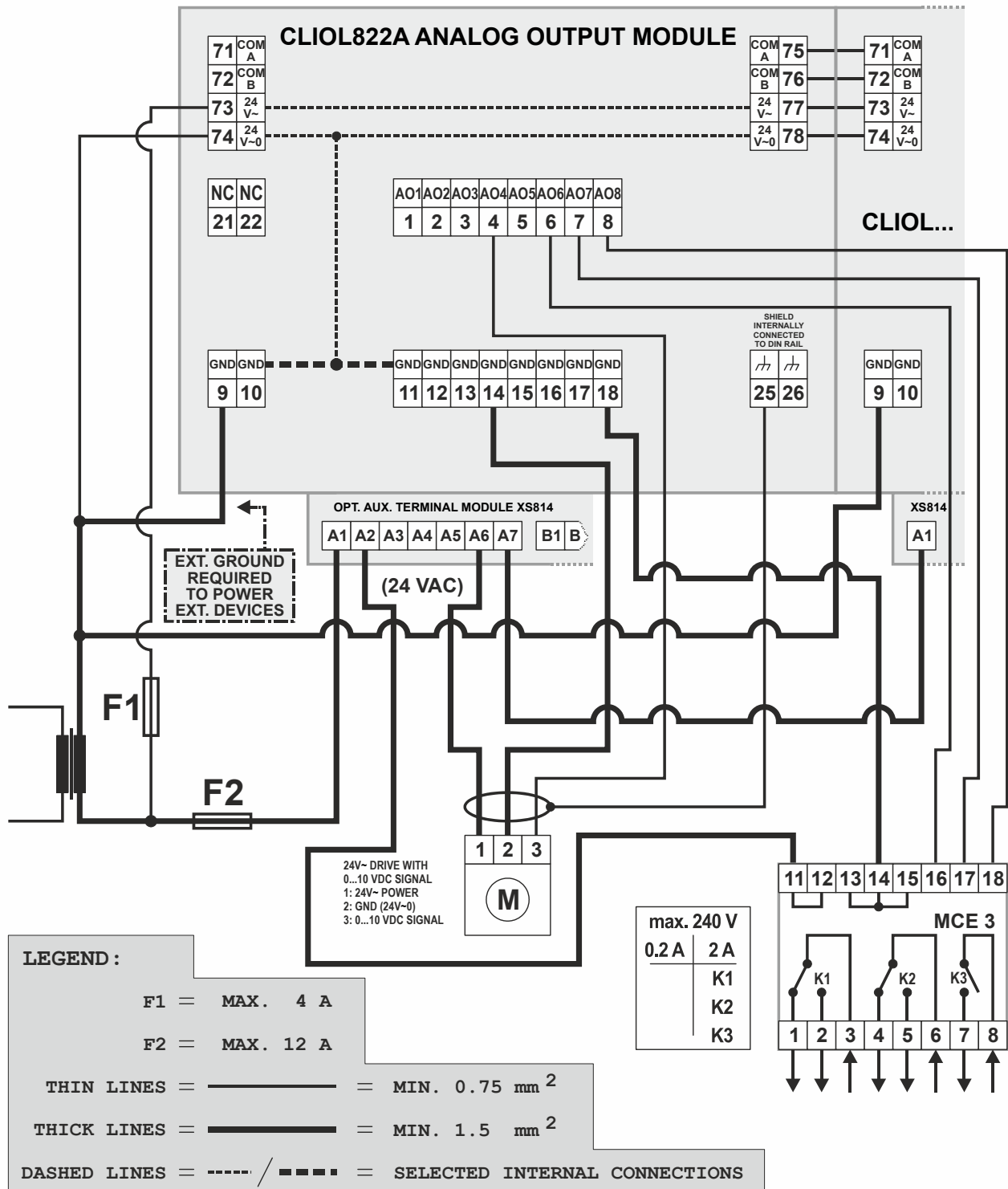

Fig. 14. CLIO822A Lonworks Bus AO Module, wiring example 3: Relay Module MCE 3

- The relay module facilitates the control of peripheral devices with high load via the analog outputs.
- Input terminal 16 of MCE3 controls the N.O. contact K3.
- Input terminal 17 of MCE3 controls the changeover contact K2.
- Input terminal 18 of MCE3 controls the changeover contact K1.

Binary Input Module

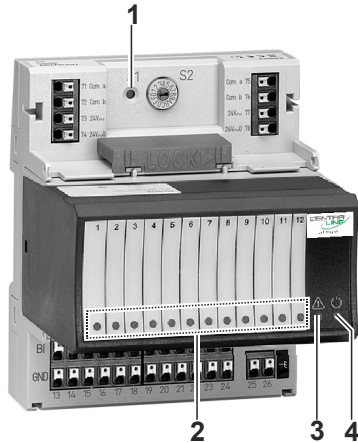

Fig. 15. CLIO823A LONWORKS Bus BI Module (shown with XS823 terminal socket)

Legend

- 1 LONWORKS service button S1
- 2 Status LEDs
- 3 Service LED
- 4 Power LED

NOTE: The hex switch S2 (located next to the LONWORKS service S1) has no function in combination with a LONWORKS Bus I/O module. It is used with Panel Bus I/O modules, only.

The CentralLine LONWORKS Bus Binary Input Module, with 12 binary inputs, is installed with the XS823 or XSU823 Terminal Socket.

Configuration as Fast Totalizer

Using CARE / COACH AX / COACH NX, the binary inputs can be configured as fast totalizers for operation in conjunction with devices equipped with an open collector output.

Table 5. Binary inputs used as fast totalizers

Frequency	max. 20 Hz
Pulse ON	min. 25 ms
Pulse OFF	min. 25 ms
Bounce	max. 5 ms

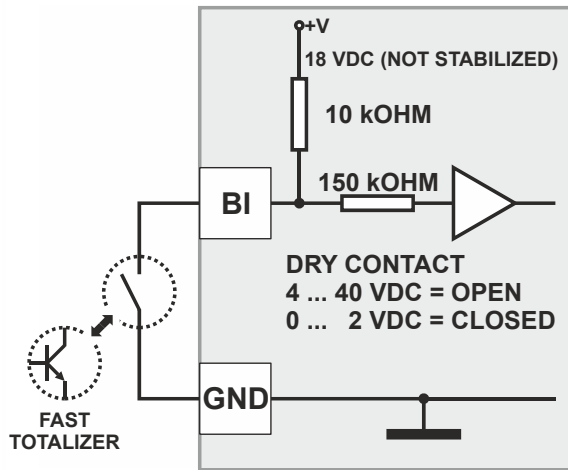

Fig. 16. Configuration of a binary input as a fast totalizer

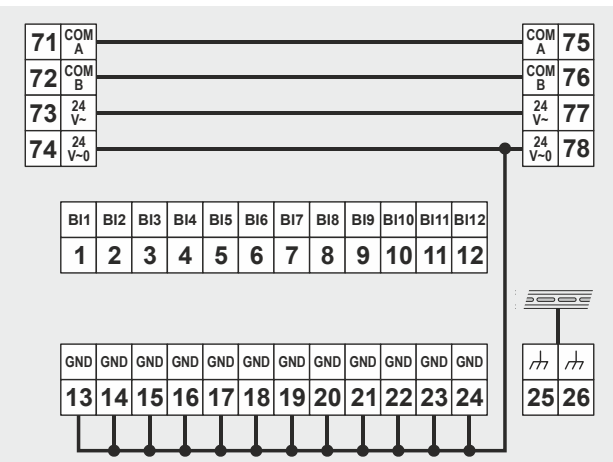
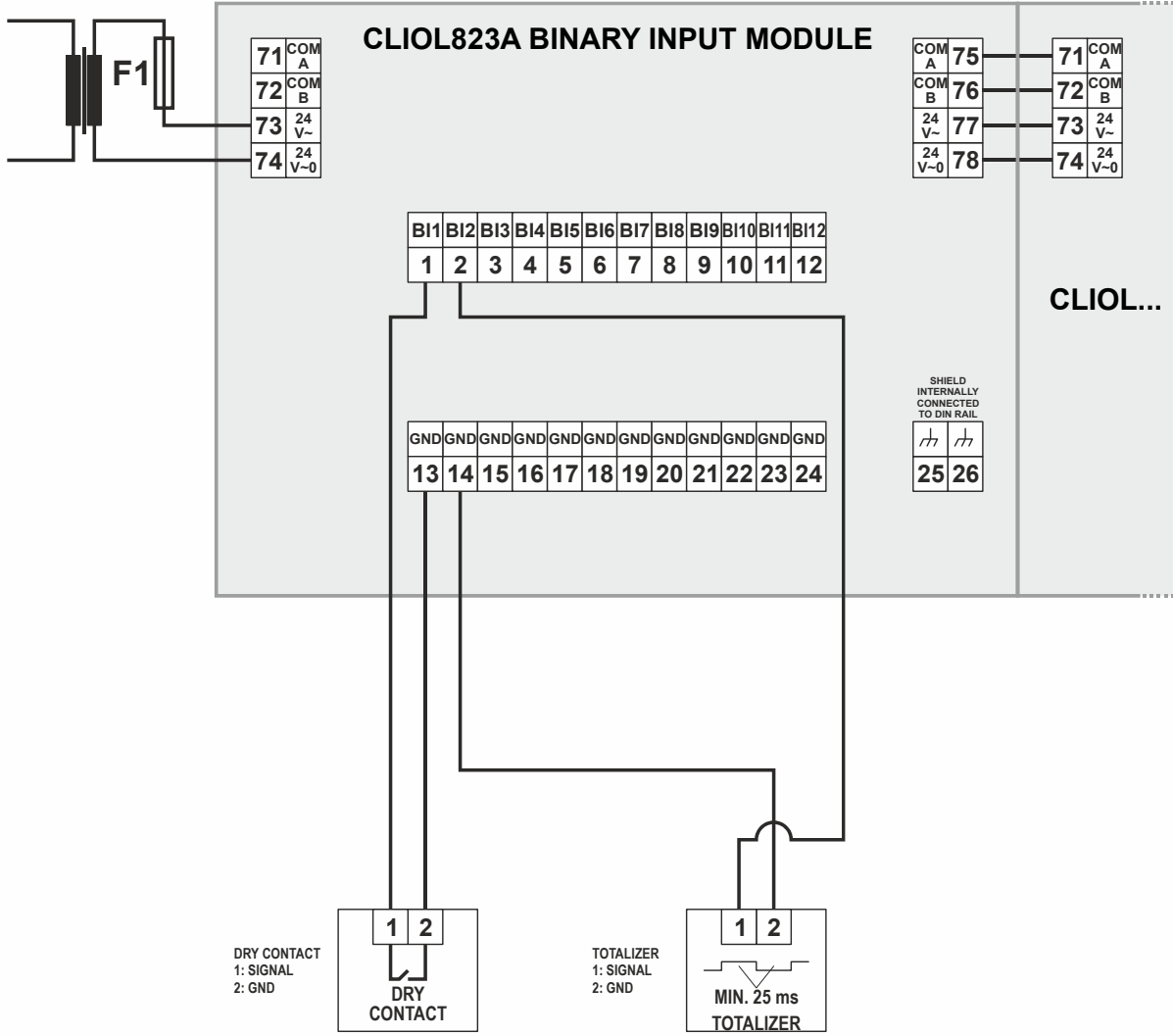

Fig. 17. CentralLine LONWORKS Bus Binary Input Modules (schematic)

Features

- Static binary input (dry contact)
- Totalizer for up to 20 Hz
- LEDs per binary input supporting alarm display mode (red/green) or status mode (off/yellow).
- Color mode of each LED can be set to OFF/yellow or green/red in CARE / COACH AX / COACH.



LEGEND :

F1 = MAX. 4 A

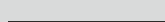
THIN LINES =  = MIN. 0.75 mm²

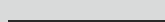
THICK LINES =  = MIN. 1.5 mm²



DASHED LINES =  /  = SELECTED INTERNAL CONNECTIONS

Fig. 18. CLIOL823A LonWorks Bus BI Module, wiring example: Dry contact and totalizer

Relay Output Modules

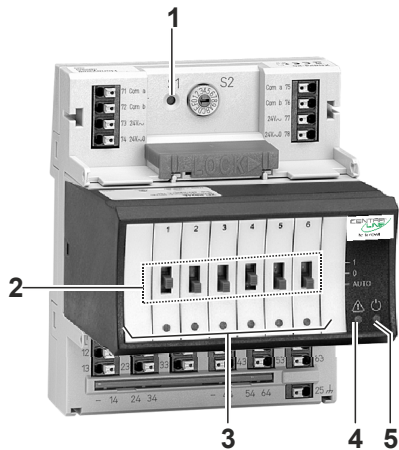

Fig. 19. CLIOLR824A LONWORKS Bus Relay Output Module (shown with terminal socket)

Legend

- 1 LONWORKS service button S1
- 2 Manual overrides
- 3 Status LEDs
- 4 Service LED
- 5 Power LED

The CentralLine LONWORKS Bus Relay Output Modules, with 6 relay outputs, are available in the following versions:

- CLIOP824A LONWORKS Bus Relay Output Module (without manual overrides)
- CLIOPR824A LONWORKS Bus Relay Output Module (with manual overrides)

They are installed with the XS824-25 or XSU824-25 Terminal Socket.

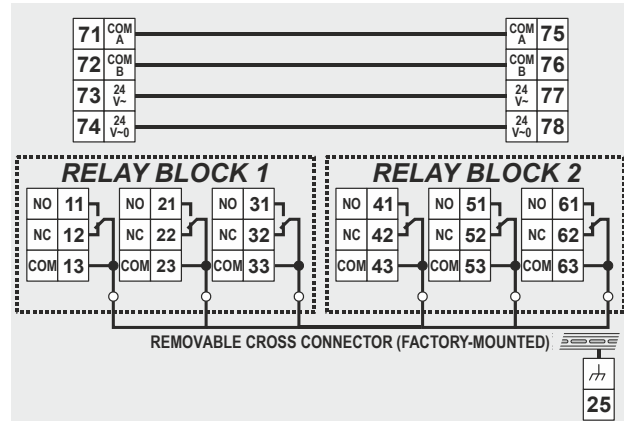
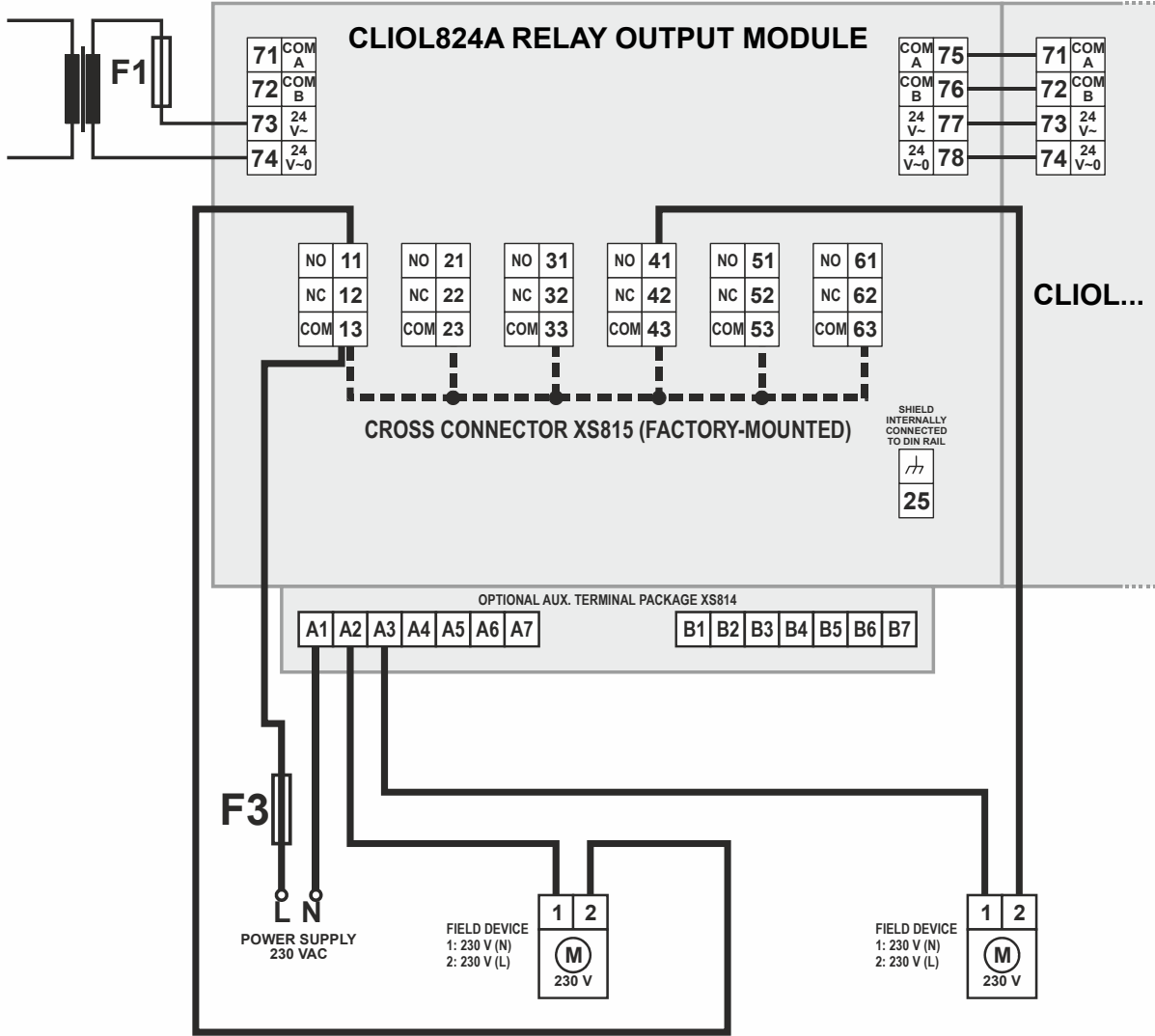

Fig. 20. CentralLine LONWORKS Bus Relay Output Modules (schematic)

Features

- Cross-Connector
- 1 yellow LED per output
- Optional versions with manual override switches (Auto, 0, 1; LED flashes in override mode)
- Feedback on manual override signal
- Configurable safety position for outputs in case of communications problems (remain, OFF, ON)
- Permissible load per Relay Output Module (total)
 - *Max. load (fuse F3):*
 - 19...250 VAC: 12 A
 - 1...29 VDC: 12 A resistive, 3 A inductive
- Permissible load per normally-open contact:
 - *Max. load:*
 - 19...250 VAC: 4 A resistive or inductive
 - 1...29 VDC: 4 A resistive, 1 A inductive
 - *Min. load:* $P > 50 \text{ mW}$
- Permissible load per normally-closed contact:
 - *Max. load:*
 - 19...250 VAC: 2 A resistive, 1 A inductive
 - 1...29 VDC: 4 A resistive, 1 A inductive
 - *Min. load:* $P > 50 \text{ mW}$



LEGEND :

F1 = MAX. 4 A

F3 = MAX. 12 A

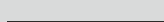
THIN LINES =  = MIN. 0.75 mm²

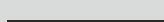
THICK LINES =  = MIN. 1.5 mm² - or less, as per F3



DASHED LINES =  /  = SELECTED INTERNAL CONNECTIONS

Fig. 21. CLIOL824A LonWorks Bus RO Module, wiring example 1: Both relay blocks with line voltage



LEGEND :

F1 = MAX. 4 A

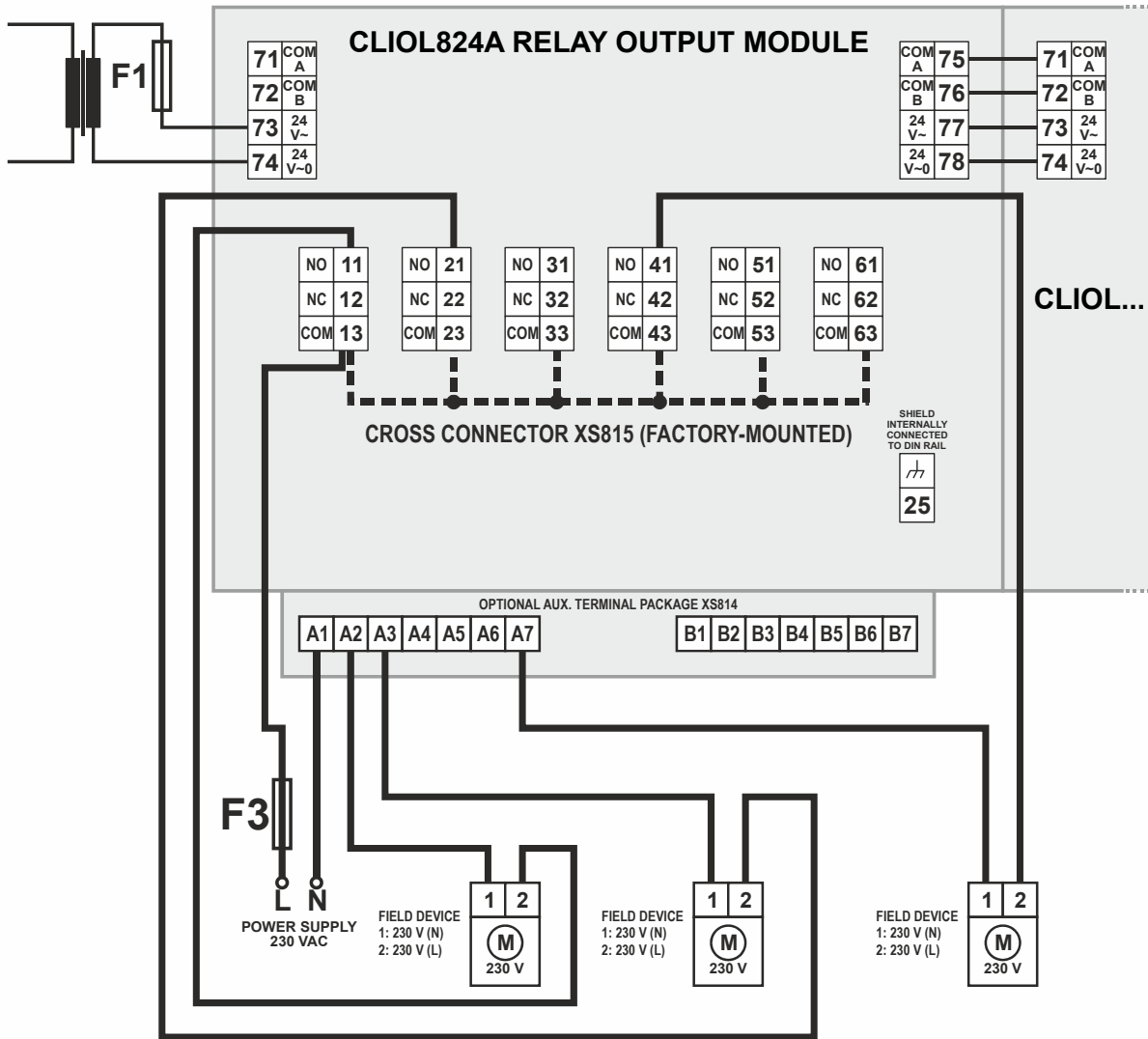
F3 = MAX. 12 A

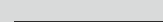
THIN LINES =  = MIN. 0.75 mm²

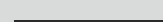
THICK LINES =  = MIN. 1.5 mm² - or less, as per F3

DASHED LINES =  /  = SELECTED INTERNAL CONNECTIONS

Fig. 22. CLIOL824A LonWorks Bus RO Module, wiring example 2: Relay blocks with low and line voltage

Approvals, Certifications, and Standards

Approvals and Certifications

- CE-approved
- Conforms to EN 60730-1 and EN 60730-2-9
- Investigated according to United States Standard UL916 (USL-listed) as well as according to Canadian National Standard(s) C22.2 (CNL-listed)

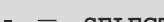
Classification according to EN60730-1

Environmental conditions: For use in home (residential, commercial, and light-industrial) environments

Pollution degree: Class 2

Protection against shock: Class II

Software class: Class A

Overvoltage category: II

Classification according to EN60529

(Degree of Protection Provided by Enclosures)
Classification: IP20

Ambient Environmental Limits

Operating temperature: 0 ... +50 °C at 5...93% r.H.

Storage temperature: -20 ... +70 °C at 5...93% r.H.

Humidity: 5 ... 93% r.h. non-condensing

Current Requirement and Heat Dissipation

The LONWORKS Bus I/O Modules are equipped with highly-efficient switching power supplies which provide for relatively uniform power consumption over a wide range of supply voltages (see Table 6). The specific heat dissipation inside the modules amounts to less than 2 W for all models.

Table 6. Current requirements at nominal voltage

devices powered	supply voltage	
	24 VAC	24 VDC
CLIOL821A	130 mA	80 mA
CLIOL822A, CLIOLR822A	150 mA	90 mA
CLIOL823A	180 mA	130 mA
CLIOL824A, CLIOLR824A	140 mA	80 mA

Mechanical

Housing Dimensions (H x W x D)

The LONWORKS Bus I/O Modules (mounted on Terminal Sockets) all have the dimensions: 110 X 90 X 93 mm (see also Fig. 23 on page 18).

Housing Material

Plastic, flame-retardant

Mounting Methods

DIN-rail mounting (e.g., in control cabinet).

Calculated Lifetime of Weakest Components

MTBF \geq 13.7 years (under typical operating conditions)

Dimensions

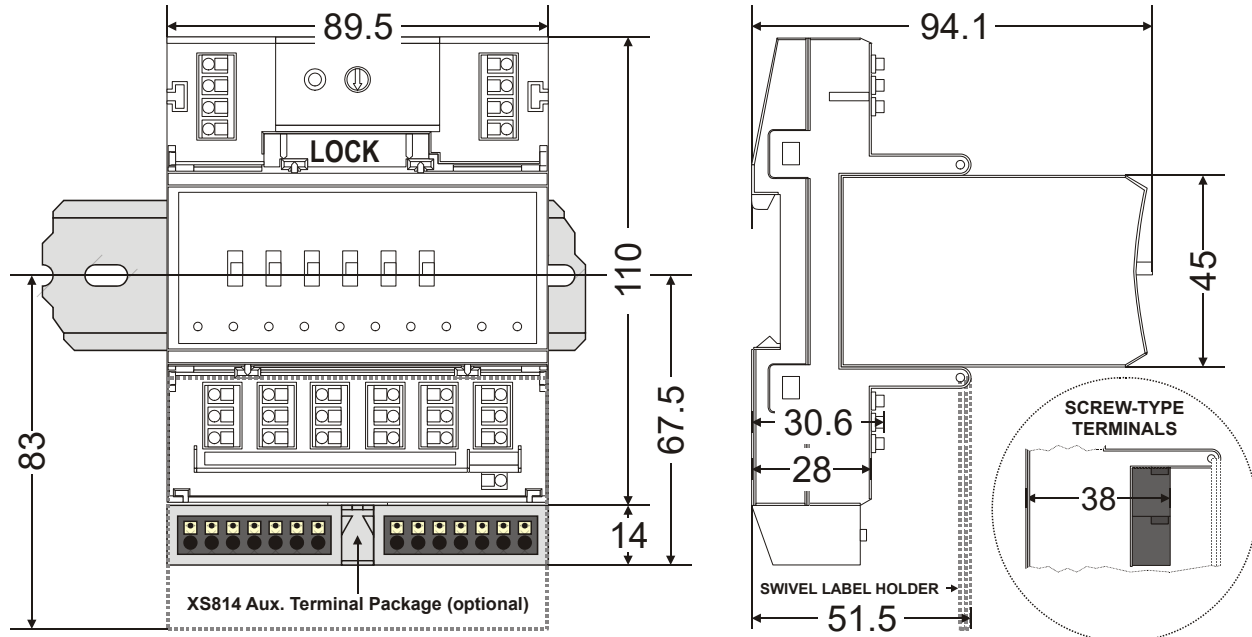

Fig. 23. Centraline LonWorks Bus I/O Modules (example shows Manual Overrides), incl. Terminal Socket, outside dimensions (in mm)

Manufactured for and on behalf of the Connected Building Division of Honeywell Products and Solutions SARL, Z.A. La Pièce, 16, 1180 Rolle, Switzerland by its Authorized Representative:

Centraline
 Honeywell GmbH
 Böblinger Strasse 17
 71101 Schönaich, Germany
 Phone +49 (0) 7031 637 845
 Fax +49 (0) 7031 637 740
info@centraline.com
www.centraline.com

Subject to change without notice
 EN0Z-0980GE51 R0119

