

GENERAL

The CentralLine Panel Bus I/O Modules communicate via the Panel Bus.

The pluggable CentralLine Panel Bus I/O modules consist of a terminal socket and a removable electronic module, allowing the socket to be mounted and wired before the electronic module is installed. All such electronic modules can be swapped out without disrupting the power and bus connections: Simply unplug the "old" and insert the "new" module.



WARNING

Risk of electric shock or equipment damage!

- ▶ Do not touch any live parts in the cabinet.
- ▶ Disconnect the power supply before you start to install the control system. More than one disconnect switch may be required to de-energize the system.
- ▶ Do not reconnect the power supply until you have completed the installation.
- ▶ Unused terminals must be closed (by completely screwing in the terminal screws), thus preventing the accidental touching of "live" parts.

The mixed CentralLine Panel Bus I/O modules offer a mix of 34 inputs and outputs in a compact housing. Software updates, configuration, and commissioning are all done automatically by the controller for all Panel Bus I/O Modules.

The Panel Bus I/O Modules are addressed manually by adjusting their HEX switches.

The Panel Bus I/O Modules may be used with any CPU supporting Panel Bus communication (e.g., the LION, EAGLE, etc.).

FEATURES

- Plug-and-play functionality for easy maintenance.
- Pluggable Panel Bus I/O modules can be exchanged without rewiring. Further, the separate installation of terminal sockets and electronic modules lower risk of damage and theft in the construction phase.
- Fast wiring with state-of-the-art push-in terminals (screw-type terminals also available) and bridge connectors.
- Wide range of sensors supported (NTC20k Ω , NTC10k Ω , PT1000-1/-2, Johnson A99 PTC, NI1000TK5000, PT3000, Balco500, 0/2...10 V, 0/4...20 mA). **NOTE:** The mixed Panel Bus I/O modules CLIOP830A and CLIOP831A feature inputs suitable for signals from NTC20k Ω sensors and 0/2...10 V, 0/4...20 mA, only!
- Binary input LEDs of the pluggable CentralLine Panel Bus I/O Modules can be configured for status display (off / yellow) or alarm display (green / red) per channel. **NOTE:** The mixed I/O modules CLIOP830A and CLIOP831A feature only non-configurable binary input LEDs!
- Configurable safety position for outputs, in case of loss of communication with the controller.
- Max. wiring flexibility due to optional accessories like auxiliary terminals and cross-connectors.
- Can be mounted in small installation housings
- Flexible mix of Panel Bus I/O modules covering all your application requirements.

OVERVIEW

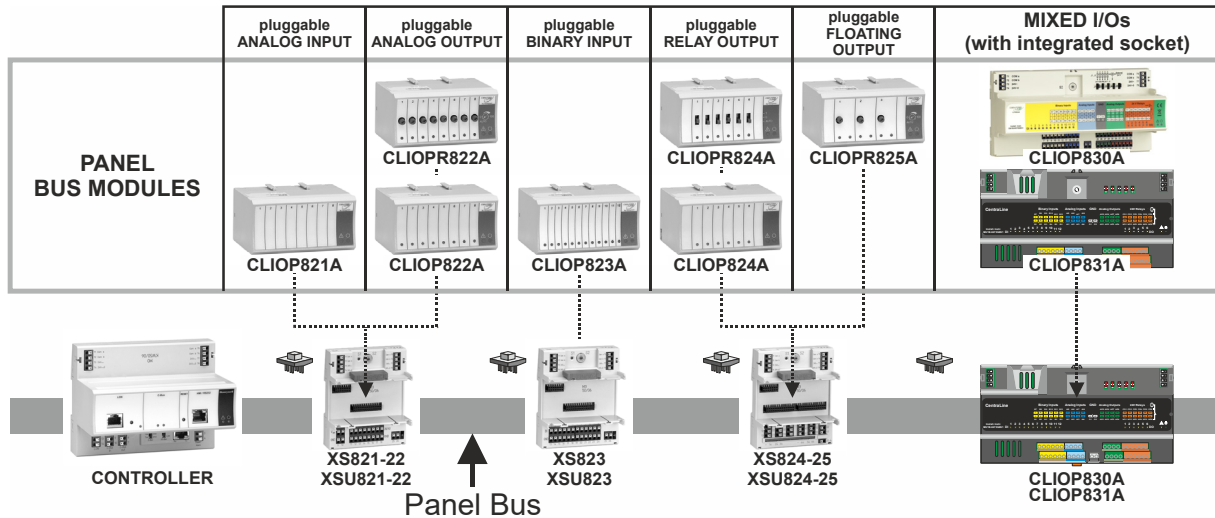





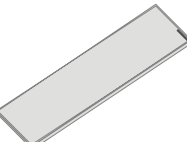

Fig. 1. Overview of CentraLine Panel Bus I/O Modules

Table 1. Overview of CentraLine Panel Bus I/O Modules

order number	description
Pluggable Panel Bus I/O Modules	
CLIOP821A	Pluggable Panel Bus Analog Input Module (with 8 analog inputs)
CLIOP822A	Pluggable Panel Bus Analog Output Module (with 8 analog outputs)
CLIOPR822A	Pluggable Panel Bus Analog Output Module (with 8 analog outputs and manual overrides)
CLIOP823A	Pluggable Panel Bus Binary Input Module (with 12 binary inputs)
CLIOP824A	Pluggable Panel Bus Relay Output Module (with 6 relay outputs)
CLIOPR824A	Pluggable Panel Bus Relay Output Module (with 6 relay outputs and manual overrides)
CLIOPR825A	Pluggable Panel Bus Floating Output Module (with 3 floating outputs and manual overrides)
Mixed Panel Bus I/O Modules with integrated socket	
CLIOP830A	Mixed Panel Bus I/O Module (with 8 AIs, 8 AOs, 12 BIs, and 6 ROs); housing fits to LION Controller housing
CLIOP831A	Mixed Panel Bus I/O Module (with 8 AIs, 8 AOs, 12 BIs, and 6 ROs); housing fits to EAGLE Controller housing
Terminal Sockets (not needed for the mixed I/O modules CLIOP830A and CLIOP831A)	
XS821-22	Push-in terminal socket for pluggable AI/AO modules (incl. bridge connector, swivel label)
XSU821-22	Screw-type terminal socket for pluggable AI/AO modules (incl. bridge connector, swivel label)
XS823	Push-in terminal socket for pluggable BI modules (incl. bridge connector, swivel label)
XSU823	Screw-type terminal socket for pluggable BI modules (incl. bridge connector, swivel label)
XS824-25	Push-in terminal socket for pluggable relay/floating output modules (incl. bridge connector, cross connector, swivel label)
XSU824-25	Screw-type terminal socket for pluggable relay/floating output modules (incl. bridge connector, cross connector, swivel label)

Table 2. Overview of auxiliary parts and spare parts

order number	description
XS814 	Ten Auxiliary Terminal Blocks (for distribution of signals/power). Each terminal block includes two groups with seven internally-connected push-in terminals. For pluggable I/O modules, only.
XS830 	Ten Auxiliary Terminal Blocks (for distribution of signals/power). Each terminal block consists of two groups of nine internally-connected push-in terminals. For CLIOP830 and CLIOP831, only.
XS831 	Ten Auxiliary Terminal Blocks (for connection of 0...20 mA signals). Each terminal block consists of two groups of four pairs of push-in terminals (each with a 499Ω resistor to GND) for supporting up to eight current inputs. For CLIOP830A and CLIOP831A, only.
XS815 	20 Cross-Connectors for connection of six relay commons. One Cross-Connector is included in the Terminal Socket package. For pluggable I/O modules, only.
XS816 	10 Bridge Connectors. One Bridge Connector is included in the Terminal Socket package.
XAL10 	10 Swivel Labels (for attaching the application-specific label printed with CARE / COACH AX / COACH NX). One Swivel Label is included in the Terminal Socket package.
XAL11 	10 Swivel Label Holders for Mixed I/O modules. One Swivel Label Holder is included in each mixed I/O module package. For mixed I/O modules, only. NOTE: Phased out.

NOTE: The inputs and outputs of all CentraLine analog and binary I/O modules are protected against short circuit, 24 VAC +20%, and 40 VDC.
 In the case of the relay outputs of other CentraLine I/O modules (i.e., relay output modules, floating output modules, and mixed I/O modules), appropriate fusing must be provided to ensure that permissible load currents are not exceeded. See also sub-section "Features" in section "Relay Output Modules" (pg. 15), "Floating Output Module" (pg. 18), and "Mixed I/O Modules" (pg. 20).

Table 3. Pluggable Panel Bus I/O Module specifications

Module	Analog Input	Analog Output	Binary Input	Relay Output	Floating Output
	CLIOP821A	CLIOP822A, CLIOPR822A	CLIOP823A	CLIOP824A, CLIOPR824A	CLIOPR825A
no. of I/Os	8 analog inputs	8 analog outputs	12 binary inputs requiring a gold contact or open collector	6 relay outputs	3 floating outputs
characteristic	<p>Linear Graph, 0...10 VDC with pull-up, 0(2)...10 VDC without pull-up <u>NTC20kΩ (-50...+150 °C, default)</u> <u>NTC10kΩ (-30...+100 °C)</u> PT₁₀₀₀₋₁ (-50...150 °C) PT₁₀₀₀₋₂ (0...400 °C) Johnson A99 (-40...+120 °C) NI1000TK5000 (-30...+130 °C) PT₃₀₀₀ (-50...150 °C) BALCO₅₀₀ (-30...120 °C)</p> <p>Also configurable as: binary inputs ▪ Linear graph (0...10 V with pull-up)</p> <p>Features:</p> <ul style="list-style-type: none"> ▪ 16-bit resolution ▪ configurable offset per input ▪ auxiliary voltage: 10 VDC, I_{max} = 5 mA 	<p>0...11 VDC / ± 1 mA, 8-bit resolution (default) Also configurable as: floating outputs or binary outputs (0 V / 10 V)</p> <p>Features:</p> <ul style="list-style-type: none"> ▪ 8-bit resolution ▪ Safety position (remain, 0%, 50%, 100%) ▪ red LED per output ▪ light intensity follows output level in auto <p>Version with manual override (R):</p> <ul style="list-style-type: none"> ▪ 1 potentiometer per output ▪ auto feedback signal (mode + value) ▪ blinking in manual override position 	<p><u>static binary input, (default: dry contact)</u> Also configurable as: totalizers (20 Hz)</p> <p>Features:</p> <ul style="list-style-type: none"> ▪ 1 LED per input ▪ Color mode can be set per input to OFF/yellow or green/red using CARE / COACH AX / COACH NX ▪ ON: < 1.6 kΩ to GND or < 2.5 V to GND, OFF: > 90 kΩ to GND or > 4 V to GND 	<p><u>relay outputs (default)</u></p> <p>Features:</p> <ul style="list-style-type: none"> ▪ Changeover relays ▪ Voltage: 19...250 VAC, 1...29 VDC, P>50 mW ▪ max. total current: 12 A ▪ current per relay: N.O.: 4(4) A (AC) or 4(1) A (DC), N.C.: 2(1) A (AC) or 4(1) A (DC) ▪ Safety position (remain, 0%, 100%) ▪ yellow LED per output <p>Version with manual override (R):</p> <ul style="list-style-type: none"> ▪ 1 switch per output ▪ auto feedback signal (mode + value) ▪ blinking in manual override position 	<p><u>floating outputs</u></p> <p>Features:</p> <ul style="list-style-type: none"> ▪ 2 relays per floating output ▪ Voltage: 19...250 VAC, 1...29 VDC, P>50 mW ▪ max. total current: 12 A ▪ current per relay: N.O.: 4(4) A (AC) or 4(1) A (DC), N.C.: 2(1) A (AC) or 4(1) A (DC) ▪ 1 potentiometer per floating output ▪ 2 LEDs per output: green: relay 1 closed, red: relay 2 closed ▪ blinking in manual override position ▪ auto feedback signal (mode + value)

Manual Overrides as per EN ISO 16484-2:2004

The manual override switches and potentiometers of the output modules (...R822A, ...R824 A, and CLIOPR825A) support direct operation as per EN ISO 16484-2:2004, section 5.4.3 "Local Priority Override/Indicating Units." Specifically, the positions of the manual override switches and potentiometers directly control the outputs – independently of the controller and HMI. When a manual override switch or potentiometer is not in its default position ("auto"), the corresponding output LED will blink continuously, and the output module will send a feedback signal with the status "manual override" and the given override position to the controller (which will then also store this information in its alarm memory).

NOTE: When updating the firmware of output modules, their outputs are turned OFF – regardless of the position of their manual override switches and/or potentiometers.

Table 4. Mixed CentralLine Panel Bus I/O module specifications (CLIOP830A and CLIOP831A)

Analog Inputs	Analog Outputs	Binary Inputs	Relay Outputs
<p>Number: 8</p> <p>Configurable types:</p> <ul style="list-style-type: none"> ▪ NTC20kΩ (-30...+110 °C) (default) ▪ Linear Graph ▪ 0...10 VDC with pull-up ▪ 0(2)...10 VDC without pull-up <p>Also configurable as:</p> <ul style="list-style-type: none"> ▪ binary inputs (static, dry contact, only) <p>Features:</p> <ul style="list-style-type: none"> ▪ 10-bit resolution ▪ configurable offset per input 	<p>Number: 8</p> <p>Configurable types:</p> <ul style="list-style-type: none"> ▪ 0...11 VDC / ± 1 mA (default) <p>Also configurable as:</p> <ul style="list-style-type: none"> ▪ binary outputs (0 V / 10 V) <p>Features:</p> <ul style="list-style-type: none"> ▪ 10-bit resolution (default) ▪ Safety position (remain, 0%, 50%, 100%) 	<p>Number: 12 (requiring a gold contact or open collector)</p> <p>Configurable types:</p> <ul style="list-style-type: none"> ▪ Static binary inputs (default: static, dry contact) ▪ ON: < 1.6 kΩ to GND or < 2.5 V to GND, OFF: > 90 kΩ to GND or > 4 V to GND <p>Also configurable as:</p> <ul style="list-style-type: none"> ▪ totalizers (15 Hz) <p>Features:</p> <ul style="list-style-type: none"> ▪ 1 yellow LED per input 	<p>Number: 6</p> <p>Configurable types:</p> <ul style="list-style-type: none"> ▪ Relay outputs (default) <p>Features:</p> <ul style="list-style-type: none"> ▪ Voltage: 24 VAC/DC, P>50 mW ▪ max. total current: 3 A (AC/DC) ▪ current per relay: 500 mA ▪ normally-open contacts: P > 50 mW, voltage: 24 V (AC/DC) ▪ 1 yellow LED per output

GENERAL FEATURES

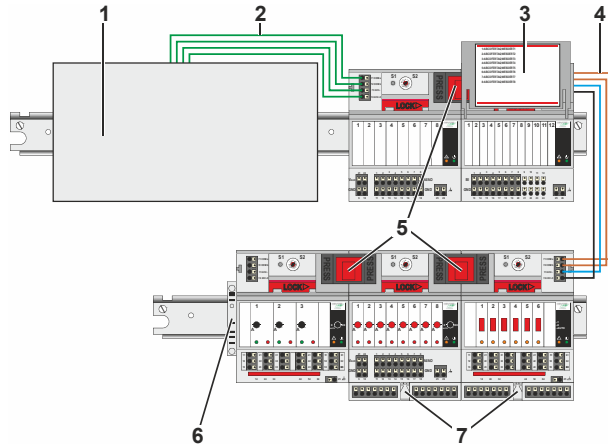

Fig. 2. CentraLine Panel Bus I/O Modules on DIN rails

Legend

- 1 Controller (e.g., LION, EAGLE, HAWK, etc.)
- 2 Cable (power, Panel Bus) connection from controller to Panel Bus I/O Modules
- 3 Swivel label holder
- 4 Cable connection between Panel Bus I/O Modules on separate DIN rails
- 5 Bridge connectors between Panel Bus I/O Modules on same DIN rail
- 6 Stopper (from 3rd-party supplier)
- 7 Auxiliary terminal packages

LEDs

Each CentraLine Panel Bus I/O Module is equipped with:

- one green power LED
- one yellow service LED

Overvoltage Protection

The inputs and outputs of all CentraLine analog and binary I/O modules are protected against short circuit, 24 VAC +20%, and 40 VDC.

In the case of the relay outputs of other CentraLine I/O modules (i.e., relay output modules, floating output modules, and mixed I/O modules), appropriate fusing must be provided to ensure that permissible load currents are not exceeded. See also sub-section "Features" in section "Relay Output Modules" (pg. 15), "Floating Output Module" (pg. 18), and "Mixed I/O Modules" (pg. 20).

Service LED

Each Panel Bus I/O Module is equipped with a yellow service LED (status: yellow/OFF) for easy diagnosis of failures.

Microprocessor

Each Panel Bus I/O Module is equipped with its own microprocessor.

Addressing

Addressing is performed using the HEX switch.

System Constraints

Table 5. System constraints

Max. no. of I/O modules (any combination) per controller	depends upon controller type
Max. no. of I/O modules per row	10
Max. current (F1)	4 A
Max. current (F2)	12 A
Max. current (F3)	12 A
Max. current (F4) (mixed I/O modules, only)	3 A
Max. row length	3 m
Max. distance between rows	40 m
Min. cross-section of GND (terminal 9) (protected by F2)	1.5 mm ²

Analog Input Module



Fig. 3. CLIO821A Panel Bus AI Module (shown with terminal socket)

Legend

- 1 Hex switch S2
- 2 Service LED
- 3 Power LED

The pluggable CentraLine Panel Bus Analog Input Module, with 8 analog inputs, is installed with the XS821-22 or XSU821-22 Terminal Socket.

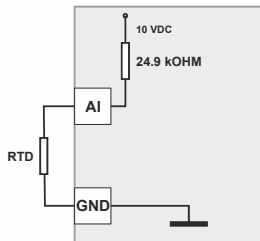

Fig. 4. Analog input low impedance (input circuit for PT1000, Johnson A99 PTC, Balco500, PT3000, NI1000TK5000, slow binary input)

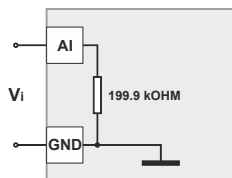

Fig. 5. Analog input high impedance (input circuit for voltage input for active sensors)

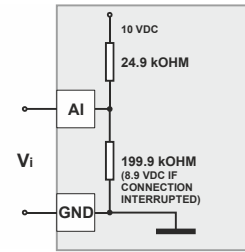

Fig. 6. Analog input impedance setpoint (input circuit for NTC10kΩ, NTC20kΩ, wall module setpoint)

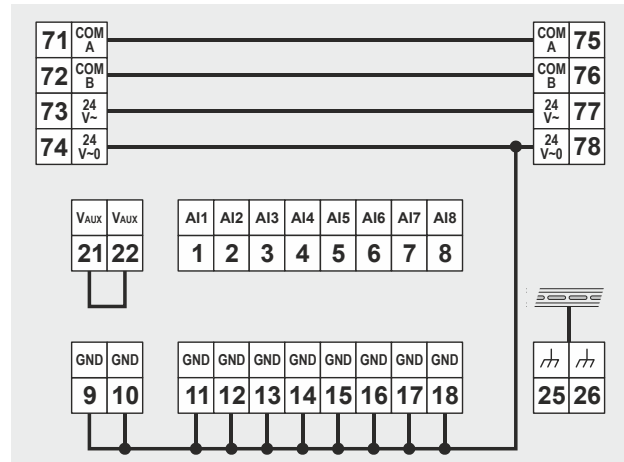

Fig. 7. CentraLine Panel Bus Analog Input Module (schematic)

Features

- 0...10 VDC, 2...10 VDC without pull-up
- 0...10 VDC with pull-up (linear graph, e.g. used for wall module connection)
- 0/4...20 mA, needs 499 Ω resistor in parallel
- NTC20kΩ (-50...+150 °C, default)
- NTC10kΩ (-30...+100 °C)
- PT1000-1 (-50...+150 °C)
- PT1000-2 (0...+400 °C)
- NI1000TK5000 (-30...+130 °C)
- PT3000 (-50...+150 °C)
- BALCO500 (-30...+120 °C)
- Binary input
- 16-bit resolution
- Configurable offset per input
- Auxiliary voltage: 10 VDC, I_{MAX} = 5 mA
- Sensor failure detection

See also section "Sensor Characteristics" on pg. 24.

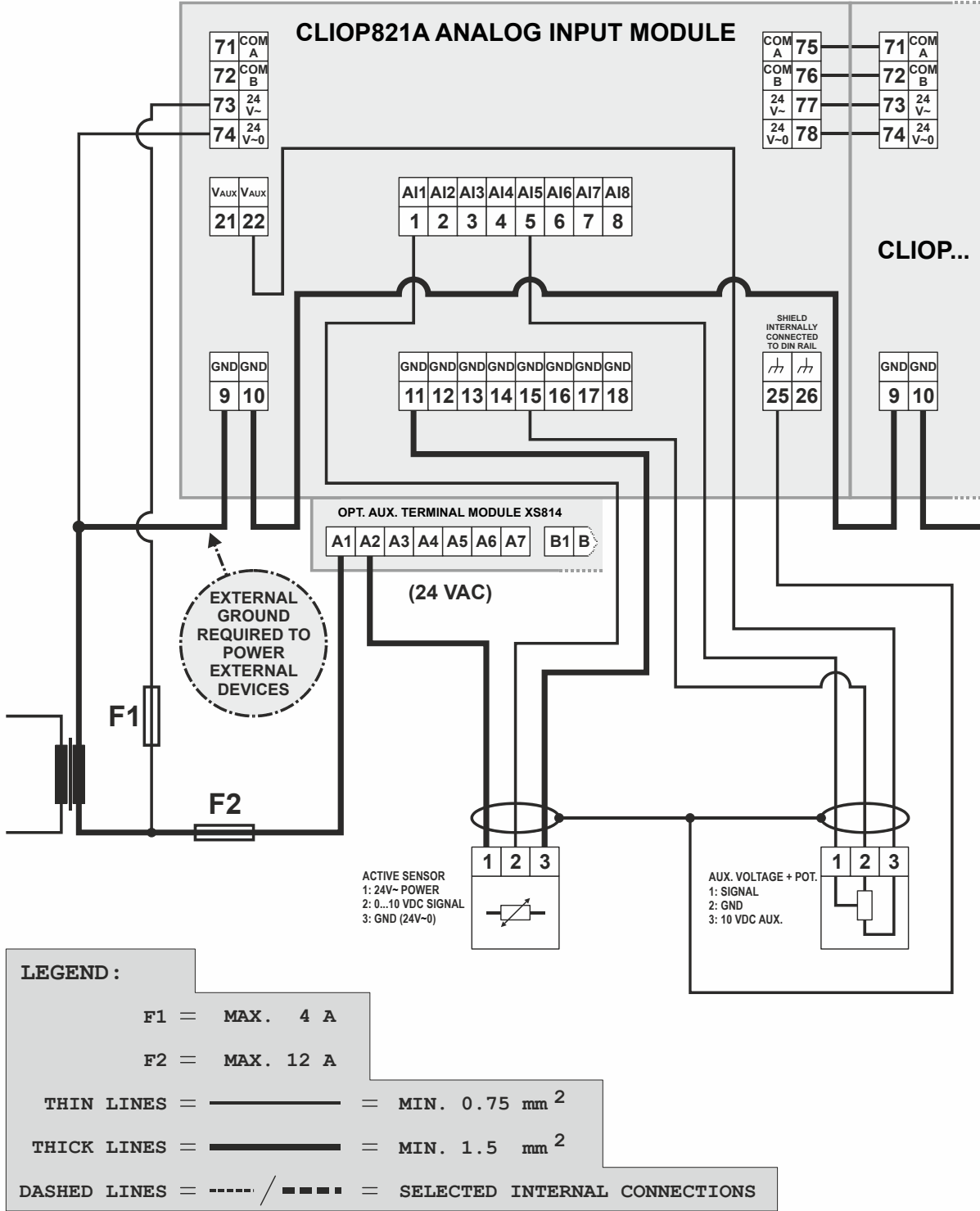

Fig. 8. CLIOP821A Panel Bus AI Module, wiring example 1: Active sensor and potentiometer

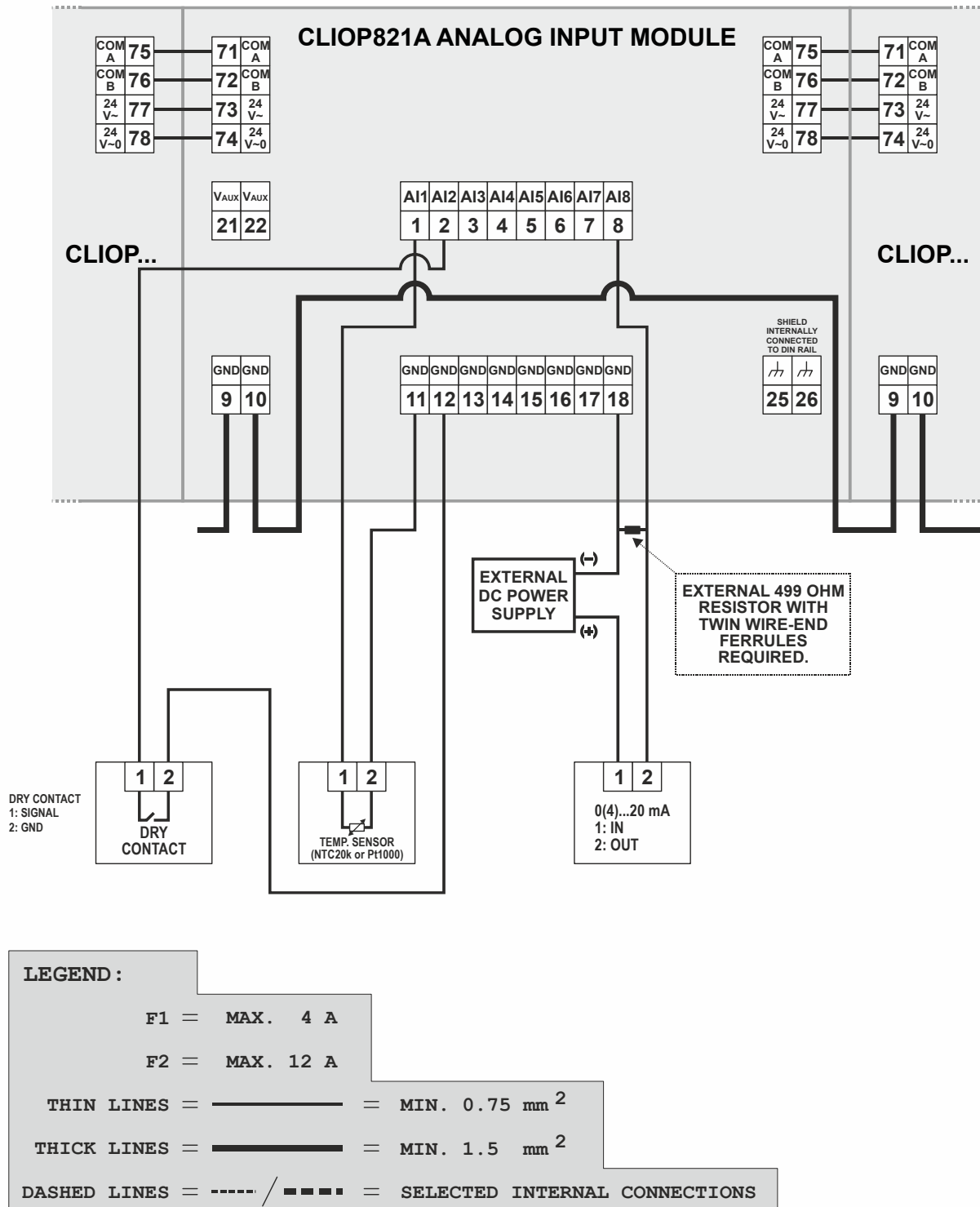

Fig. 9. CLIOP821A Panel Bus AI Module, wiring example 2: Passive sensor and 0 (4) ... 20 mA signal

Analog Output Modules

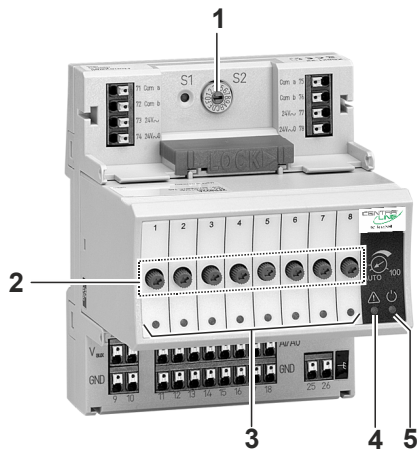

Fig. 10. CLIOPR822A Panel Bus AO Module (shown with terminal socket)

Legend

- 1 Hex switch S2
- 2 Manual overrides
- 3 Status LEDs
- 4 Service LED
- 5 Power LED

The pluggable CentralLine Panel Bus Analog Output Modules, with 8 analog outputs, are available in the following models:

- CLIOP822A Panel Bus Analog Output Module (without manual overrides)
- CLIOPR822A Panel Bus Analog Output Module (with manual overrides)

They are installed with the XS821-22 or XSU821-22 Terminal Socket.

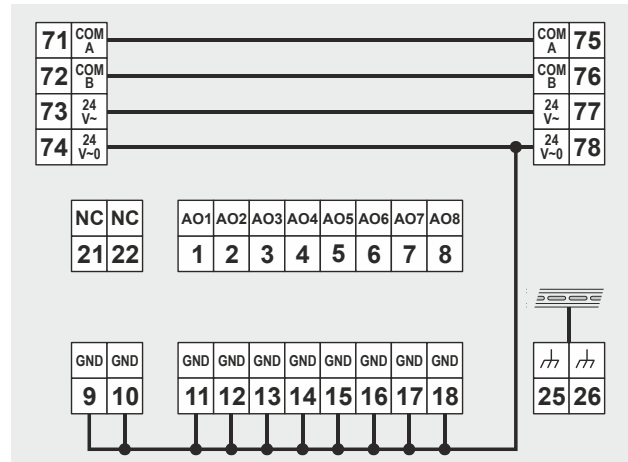

Fig. 11. CentralLine Panel Bus Analog Output Modules (schematic)

Features

- 0...11 VDC, +/-1 mA
- Floating actuator (requires MCD3)
- Binary output (0 V / 10 V)
- red LED per output (brightness according to signal level)
- Optional versions with manual override potentiometers (Auto, 0...100%; LED flashes in override mode)
- Feedback on manual override signal
- 8-bit resolution
- Configurable safety position for outputs in case of communication problems (remain, 0%, 50%, 100%)

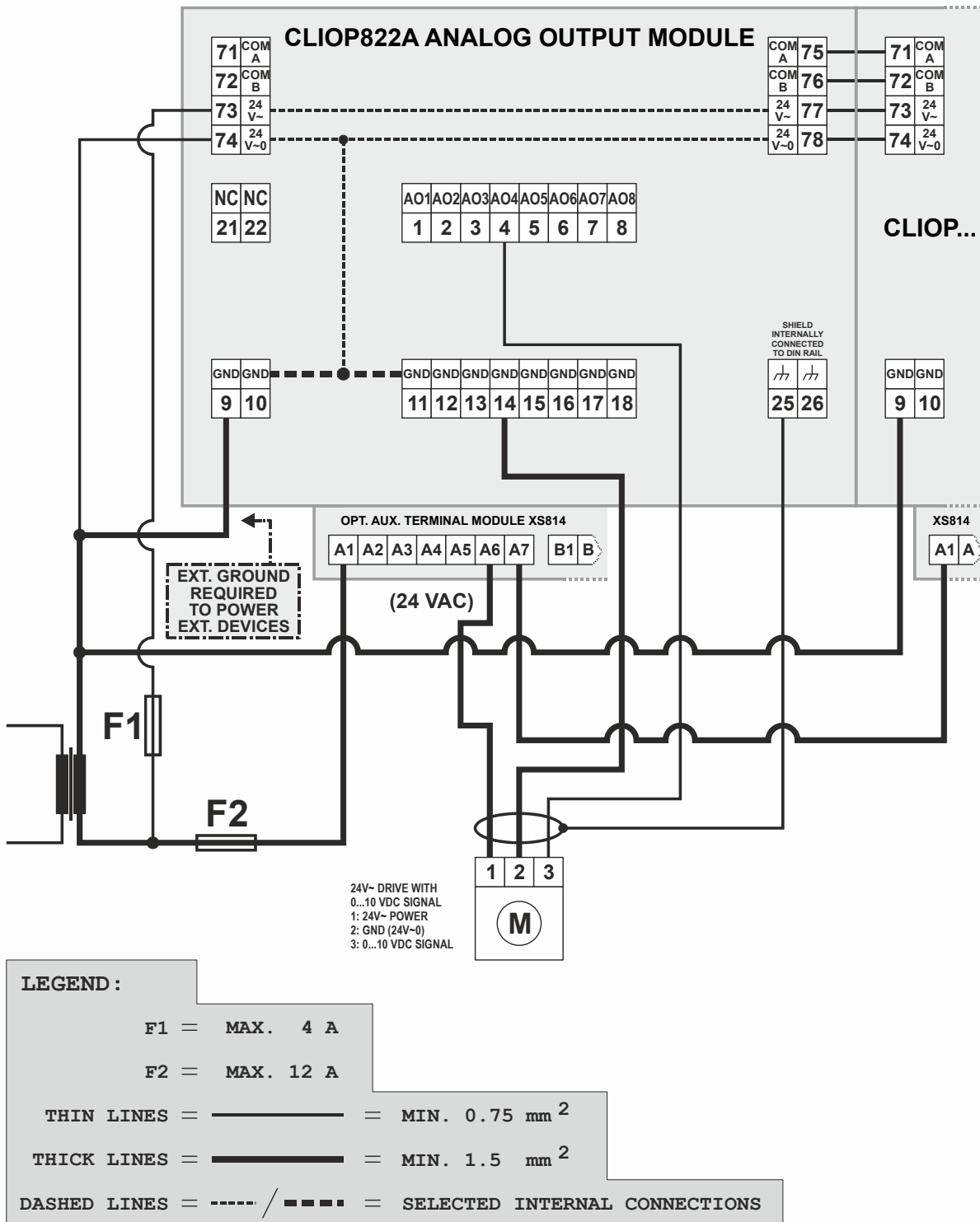

Fig. 12. CLIOP822A Panel Bus AO Module, wiring example 1: Actuator

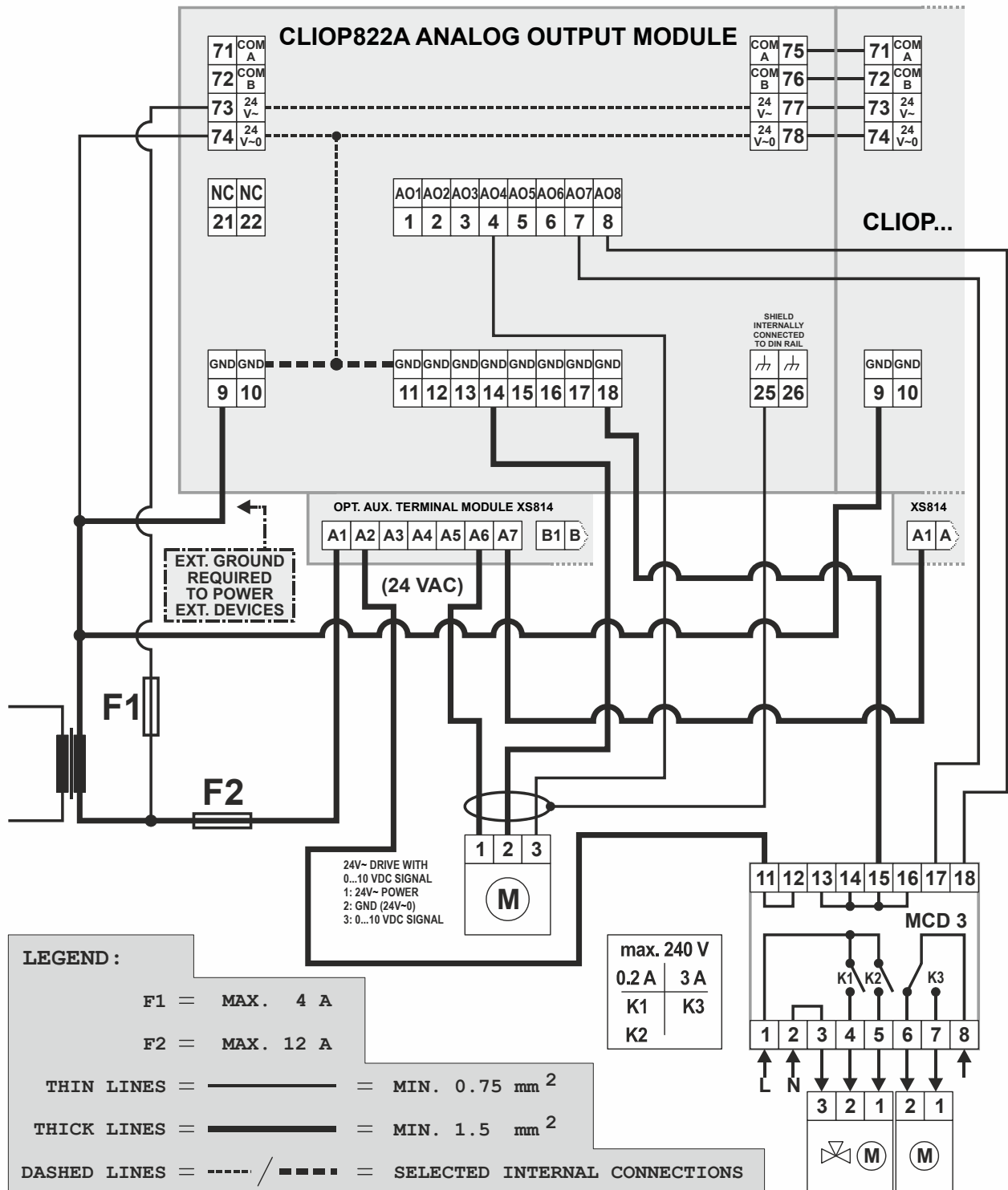

Fig. 13. CLIO822A Panel Bus AO Module, wiring example 2: Relay Module MCD 3

- The relay module facilitates the control of peripheral devices with high load via the analog outputs.
- Input terminal 17 of MCD3 controls changeover contact K3.
- Relay terminal 18 of MCD3 controls the N.O. contacts (floating outputs) K1, K2.

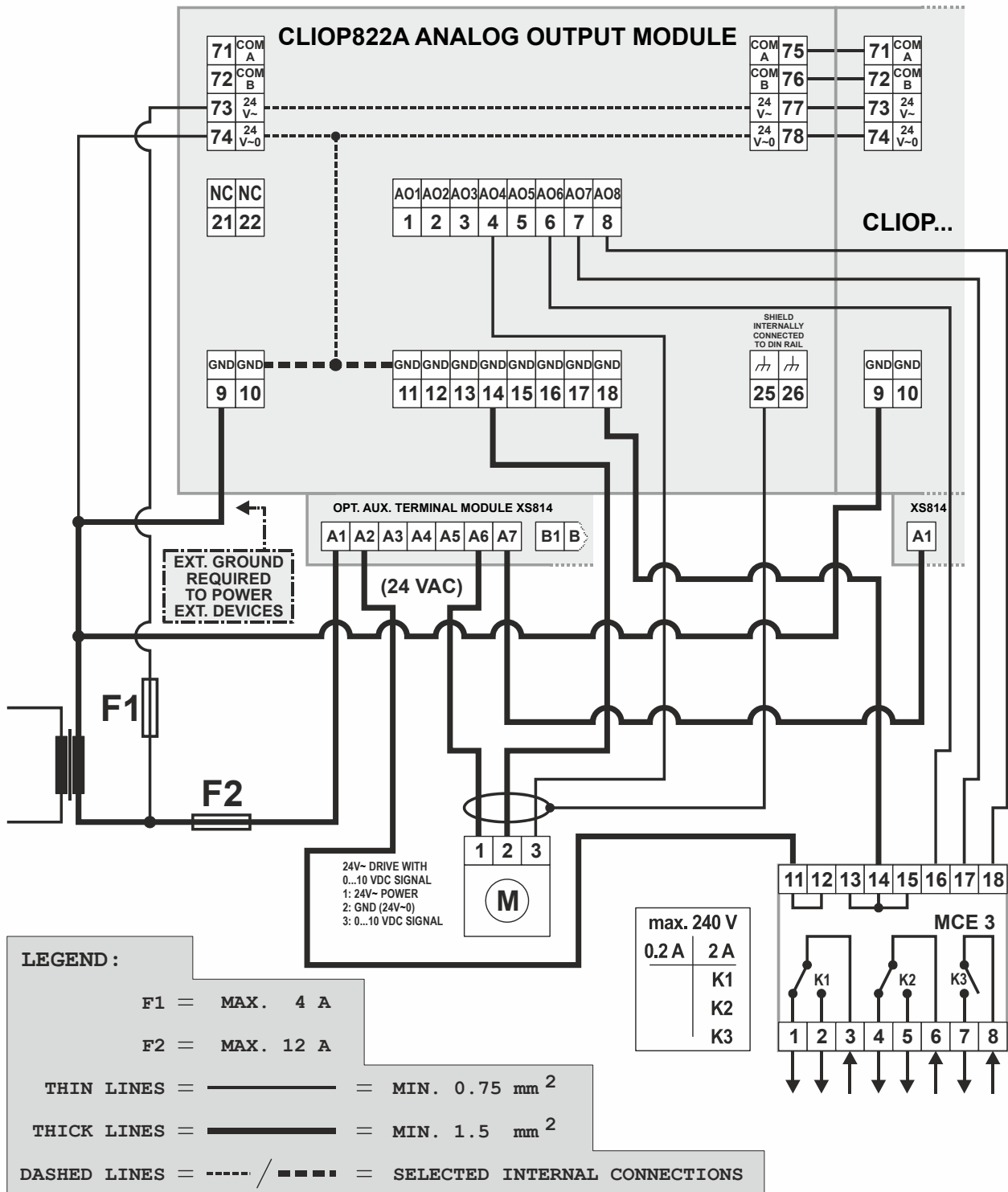

Fig. 14. CLIOP822A Panel Bus AO Module, wiring example 3: Relay Module MCE 3

The relay module facilitates the control of peripheral devices with high load via the analog outputs.

- Input terminal 16 of MCE3 controls the N.O. contact K3.
- Input terminal 17 of MCE3 controls the changeover contact K2.
- Input terminal 18 of MCE3 controls the changeover contact K1.

Binary Input Module



Fig. 15. CLIO823A Panel Bus BI Module (shown with XS823 terminal socket)

Legend

- 1 Hex switch S2
- 2 Status LEDs
- 3 Service LED
- 4 Power LED

The pluggable CentralLine Panel Bus Binary Input Module, with 12 binary inputs, is installed with the XS823 or XSU823 Terminal Socket.

Configuration as Fast Totalizer

Using CARE / COACH AX / COACH NX, the binary inputs can be configured as fast totalizers for operation in conjunction with devices equipped with an open collector output.

Table 6. Binary inputs used as fast totalizers

Frequency	max. 20 Hz
Pulse ON	min. 25 ms
Pulse OFF	min. 25 ms
Bounce	max. 5 ms

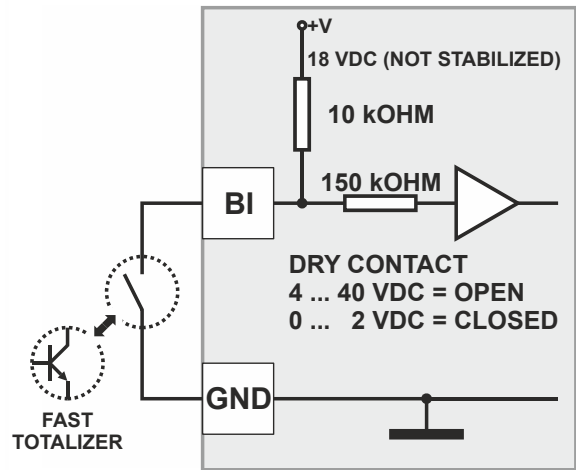

Fig. 16. Configuration of a binary input as a fast totalizer

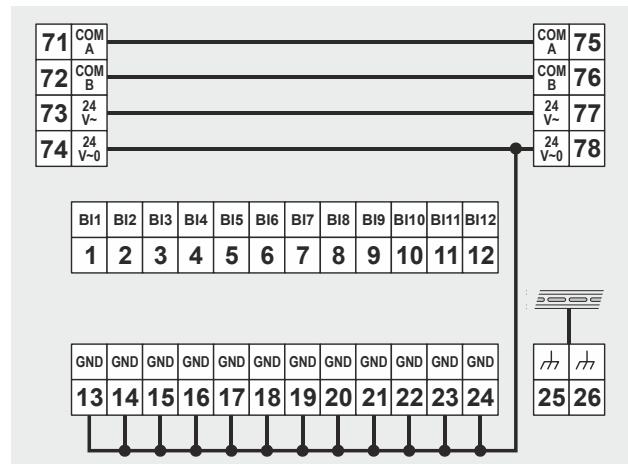
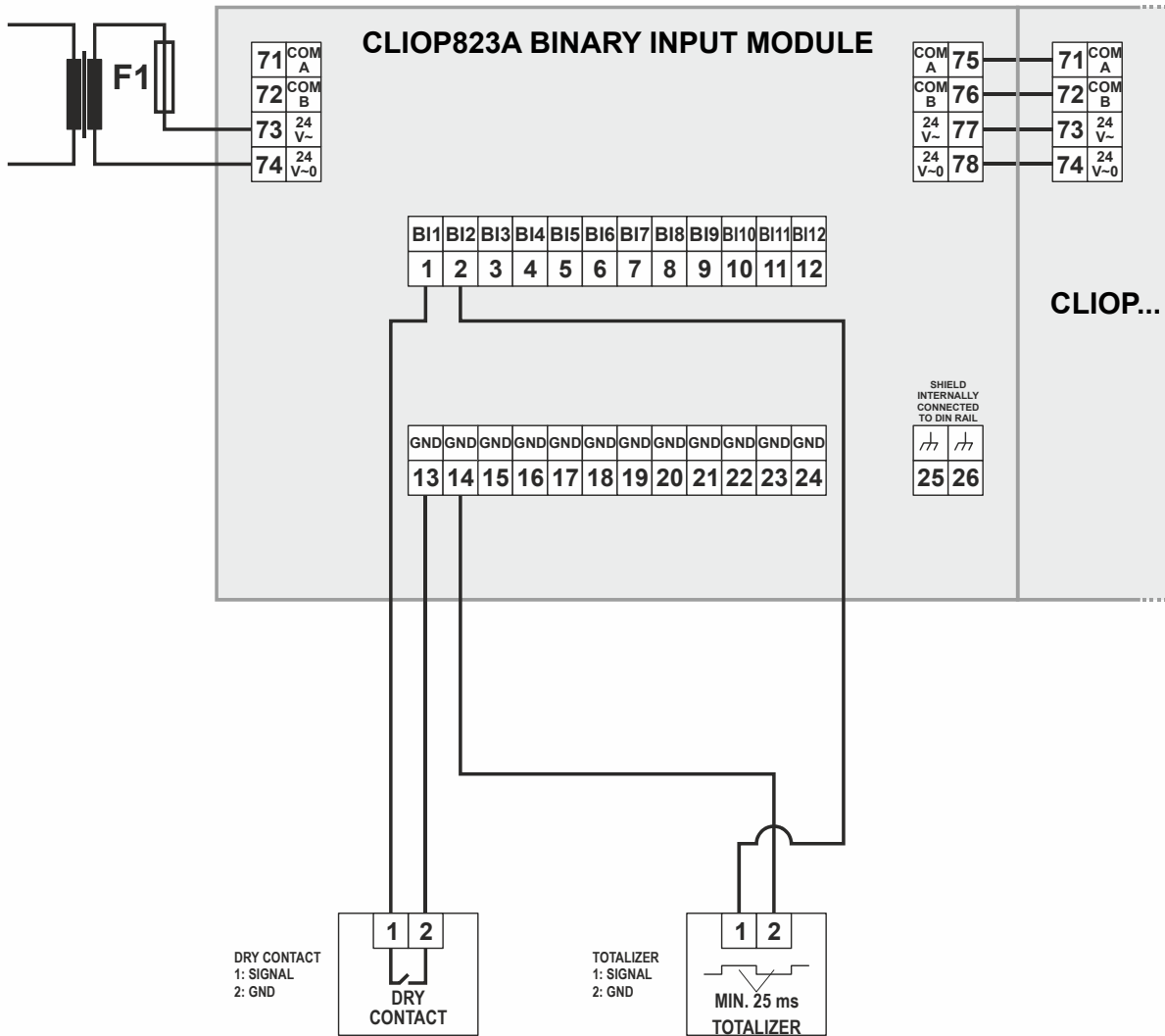

Fig. 17. CentralLine Panel Bus Binary Input Modules (schematic)

Features

- Static binary input (dry contact)
- Totalizer for up to 20 Hz
- LEDs per binary input supporting alarm display mode (red/green) or status mode (off/yellow).
- Color mode of each LED can be set to OFF/yellow or green/red in CARE / COACH AX / COACH NX.



LEGEND :

F1 = MAX. 4 A

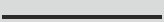
THIN LINES =  = MIN. 0.75 mm²

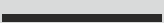
THICK LINES =  = MIN. 1.5 mm²



DASHED LINES =  /  = SELECTED INTERNAL CONNECTIONS

Fig. 18. CLIOP823A Panel Bus BI Module, wiring example: Dry contact and totalizer

Relay Output Modules

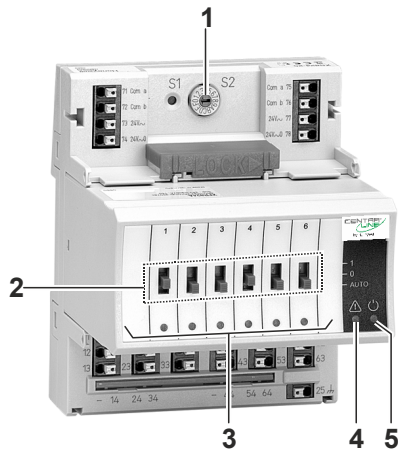

Fig. 19. CLIOPR824A Panel Bus Relay Output Module (shown with terminal socket)

Legend

- 1 Hex switch S2
- 2 Manual overrides
- 3 Status LEDs
- 4 Service LED
- 5 Power LED

The pluggable CentralLine Panel Bus Relay Output Modules, with 6 relay outputs, are available in the following versions:

- CLIOP824A Panel Bus Relay Output Module (without manual overrides)
- CLIOPR824A Panel Bus Relay Output Module (with manual overrides)

They are installed with the XS824-25 or XSU824-25 Terminal Socket.

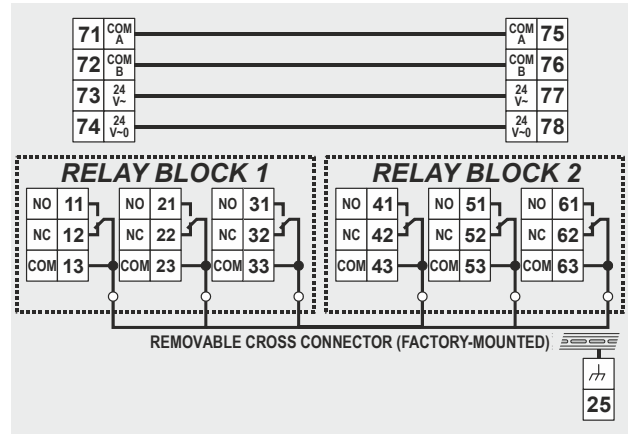
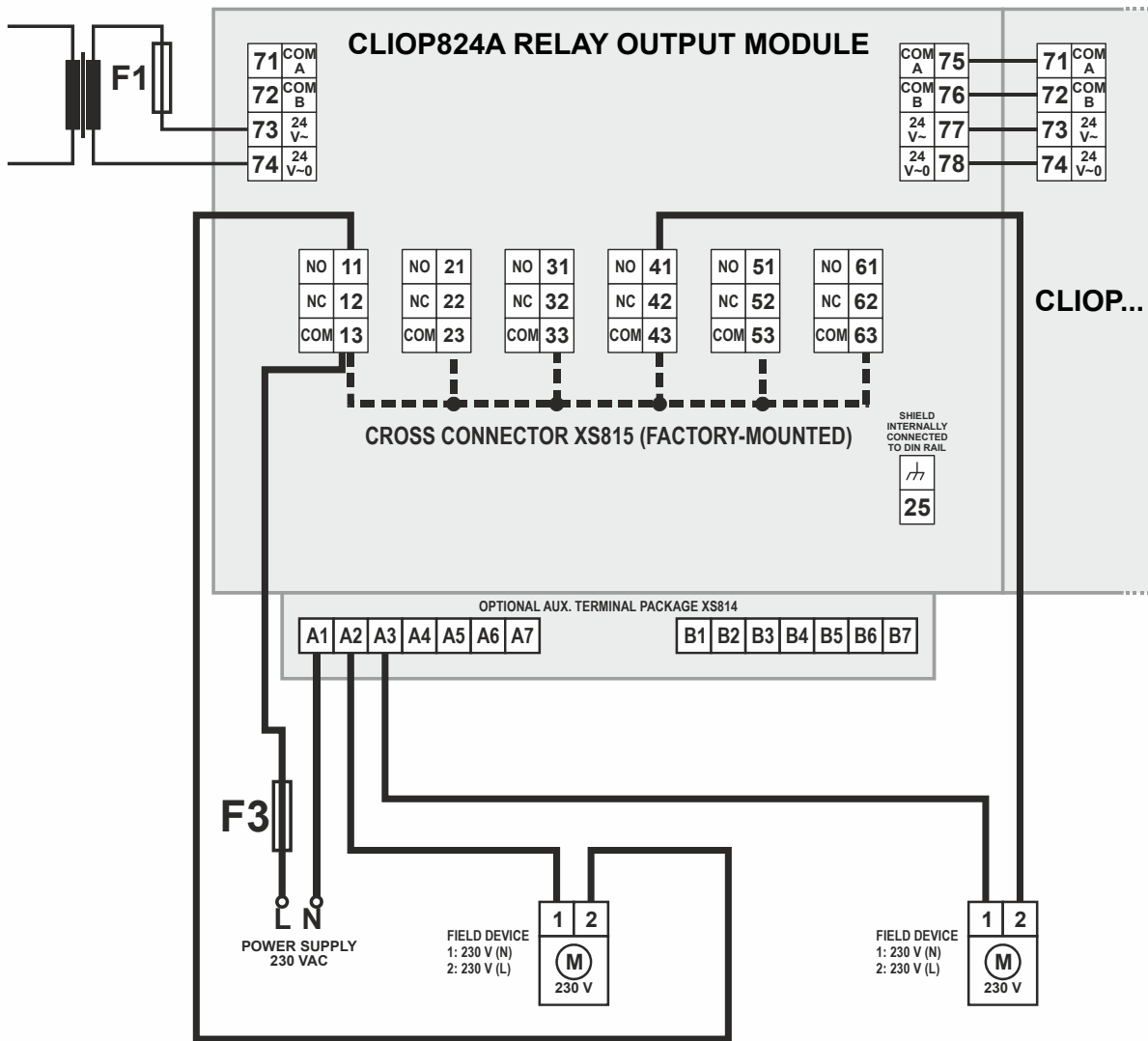

Fig. 20. CentralLine Panel Bus Relay Output Modules (schematic)

Features

- Cross-Connector
- 1 yellow LED per output
- Optional versions with manual override switches (Auto, 0, 1; LED flashes in override mode)
- Feedback on manual override signal
- Configurable safety position for outputs in case of communications problems (remain, OFF, ON)
- Permissible Load per Relay Output Module (Total)
 - *Max. load (fuse F3):*
 - 19...250 VAC: 12 A
 - 1...29 VDC: 12 A resistive, 3 A inductive
- Permissible Load per Normally-Open Contact:
 - *Max. load:*
 - 19...250 VAC: 4 A resistive or inductive
 - 1...29 VDC: 4 A resistive, 1 A inductive
 - *Min. load:* P > 50 mW
- Permissible Load per Normally-Closed Contact:
 - *Max. load:*
 - 19...250 VAC: 2 A resistive, 1 A inductive
 - 1...29 VDC: 2 A resistive, 1 A inductive
 - *Min. load:* P > 50 mW



LEGEND :

F1 = MAX. 4 A

F3 = MAX. 12 A

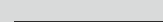
THIN LINES =  = MIN. 0.75 mm²

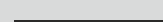
THICK LINES =  = MIN. 1.5 mm² - or less, as per F3



DASHED LINES =  /  = SELECTED INTERNAL CONNECTIONS

Fig. 21. CLIOP824A Panel Bus RO Module, wiring example 1: Both relay blocks with line voltage



LEGEND :

F1 = MAX. 4 A

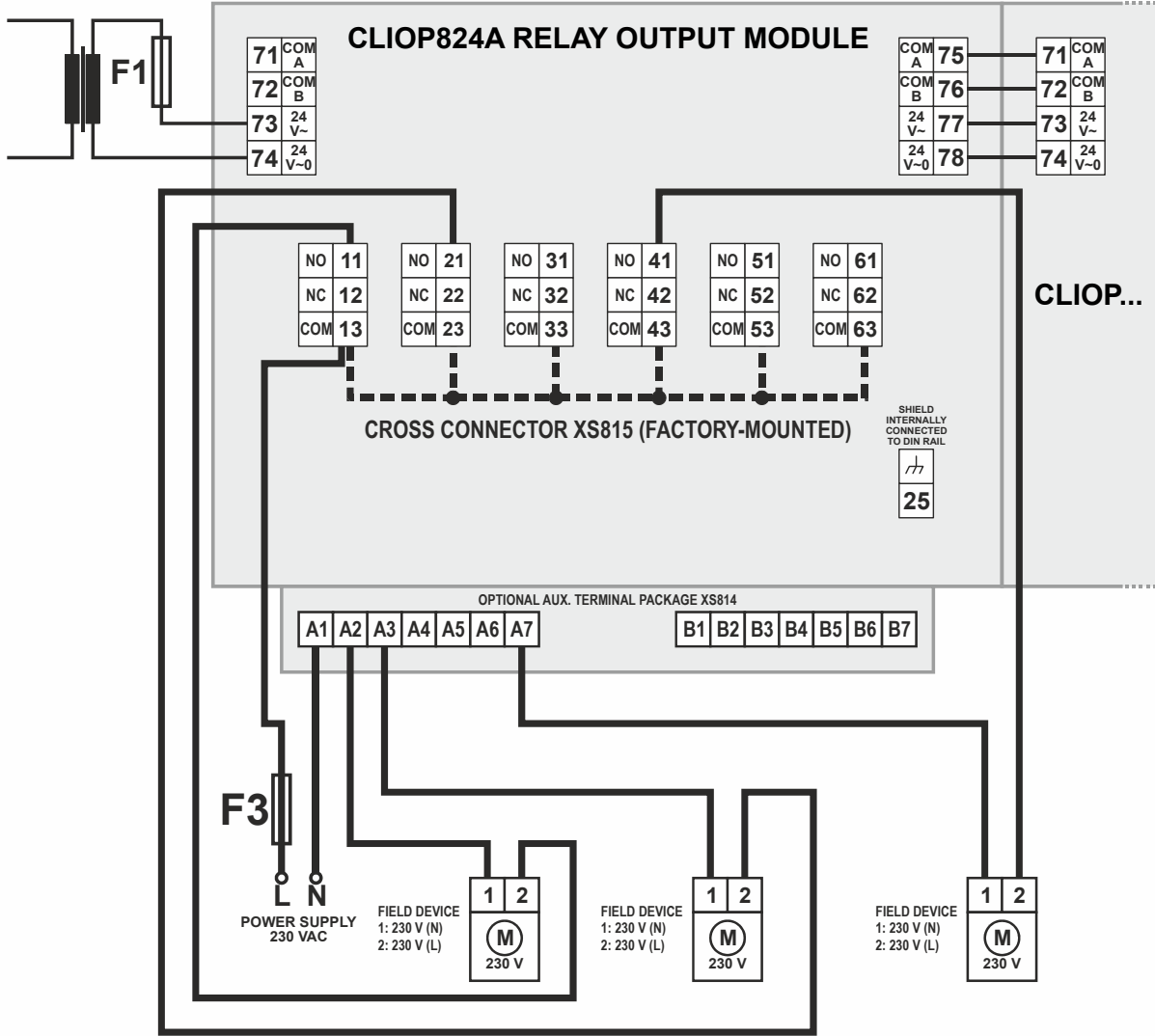
F3 = MAX. 12 A

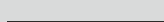
THIN LINES =  = MIN. 0.75 mm²

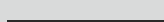
THICK LINES =  = MIN. 1.5 mm² - or less, as per F3



DASHED LINES =  /  = SELECTED INTERNAL CONNECTIONS

Fig. 22. CLIOP824A Panel Bus RO Module, wiring example 2: Relay blocks with low and line voltage

Floating Output Module

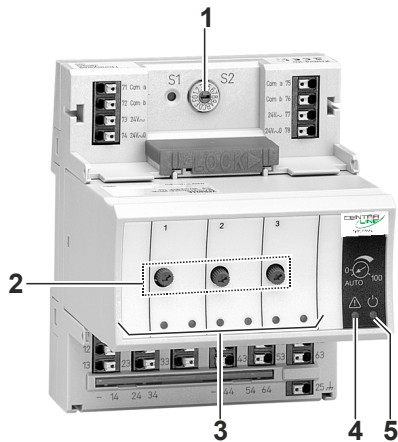

Fig. 23. CLIOPR825A Panel Bus Floating Output Module (shown with terminal socket)

Legend

- 1 Hex switch S2
- 2 Manual overrides
- 3 Status LEDs
- 4 Service LED
- 5 Power LED

The pluggable CLIOPR825A Panel Bus Floating Output Module, with manual overrides and 3 floating outputs, is installed with the XS824-25 or XSU824-25 Terminal Socket.

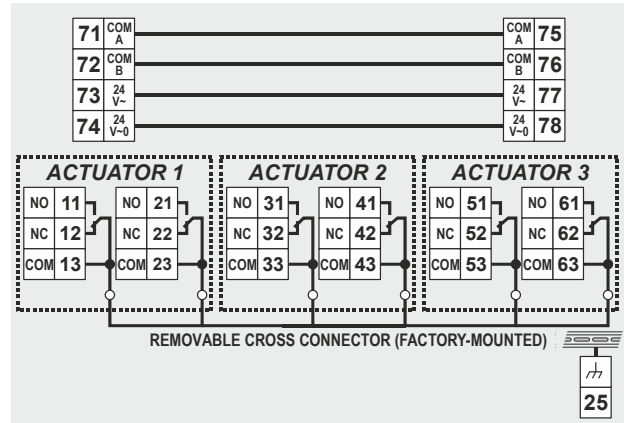
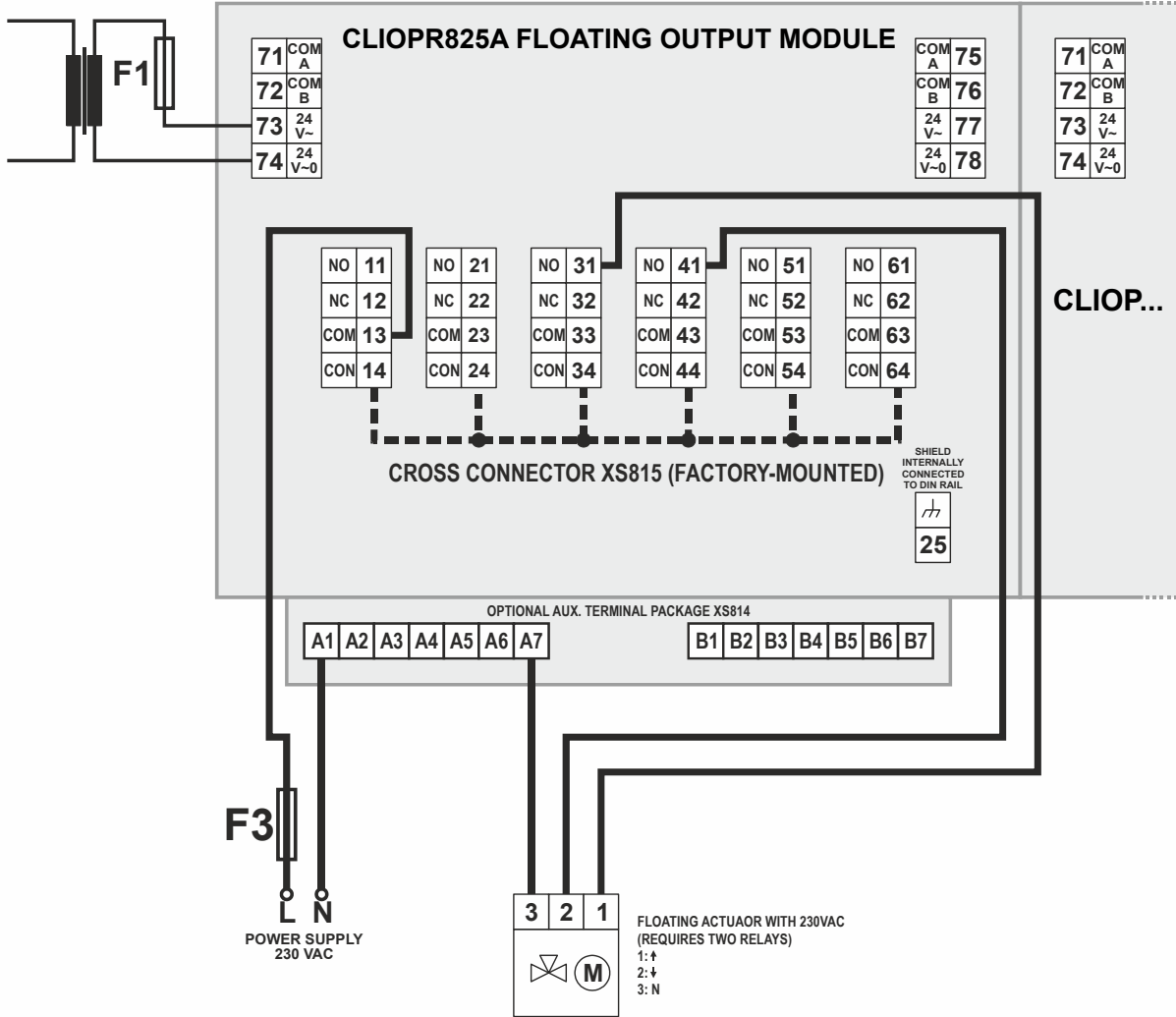

Fig. 24. CentraLine Panel Bus Floating Output Module (schematic)

Features

- Cross-Connector
- 1 red LED (opening) and 1 green LED (closing) per floating output
- Manual override potentiometers (Auto, 0%...100%; LED flashes in override mode)
- Feedback on manual override signal
- Configurable safety position for outputs in case of communication problems (remain, 0%, 50%, 100%)
- Permissible Load per Floating Output Module (Total)
 - *Max. load (fuse F3):*
 - 19...250 VAC: 12 A
 - 1...29 VDC: 12 A resistive, 3 A inductive
 - Permissible Load per Normally-Open Contact:
 - *Max. load:*
 - 19...250 VAC: 4 A resistive or inductive
 - 1...29 VDC: 4 A resistive, 1 A inductive
 - *Min. load:* P > 50 mW
 - Permissible Load per Normally-Closed Contact:
 - *Max. load:*
 - 19...250 VAC: 2 A resistive, 1 A inductive
 - 1...29 VDC: 2 A resistive, 1 A inductive
 - *Min. load:* P > 50 mW



LEGEND :

F1 = MAX. 4 A

F3 = MAX. 12 A

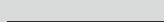
THIN LINES =  = MIN. 0.75 mm²

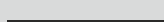
THICK LINES =  = MIN. 1.5 mm² - or less, as per F3



DASHED LINES =  /  = SELECTED INTERNAL CONNECTIONS

Fig. 25. CLIOPR825A Panel Bus FO Module, wiring example: Floating actuator

Mixed I/O Modules
CLiop830A



CLiop831A

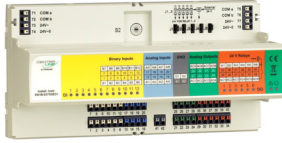
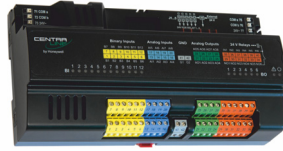

Fig. 26. Mixed Panel Bus Modules

The CLiop830A and CLiop831A mixed Panel Bus I/O modules feature 8 analog inputs, 8 analog outputs, 12 binary inputs, and 6 relay outputs. The CLiop830A is equipped with push-in terminals, while the CLiop831A features screw-type terminals. Both feature an integrated terminal socket and electronic module. The CLiop830A can be equipped with up to two rows of (XS830 and/or XS831) auxiliary terminal blocks on the top and/or bottom. The CLiop831A can be equipped with up to two rows of (XS830 and/or XS831) auxiliary terminal blocks on the top, only.

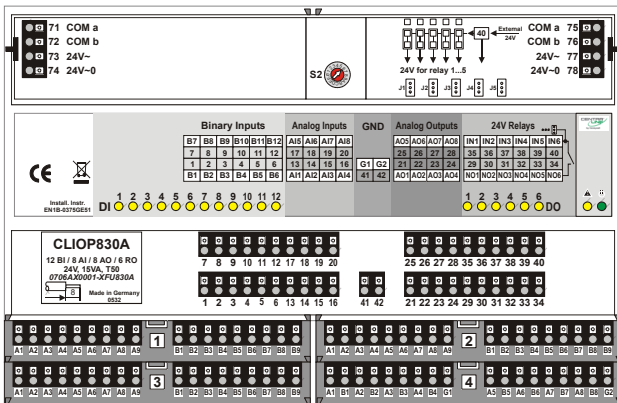

Fig. 27. CLiop830A mixed Panel Bus I/O module, shown with 4 optional aux. terminal blocks (top view)

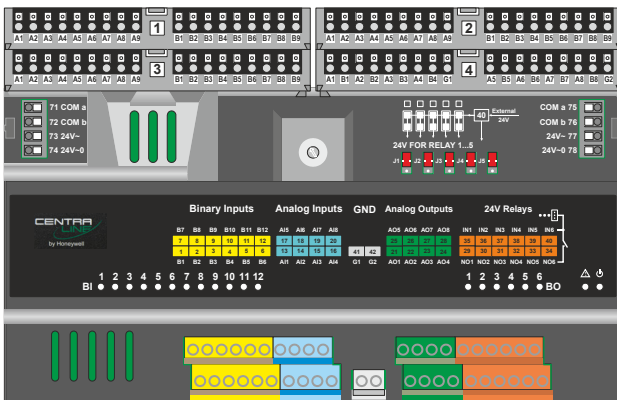

Fig. 28. CLiop831A mixed Panel Bus I/O module, shown with 4 optional aux. terminal blocks (top view)

Features

- 1 yellow LED per output
- Configurable safety position for outputs in case of communications problems (remain in last position, OFF, ON)

Table 7. Permissible loads of Mixed Panel Bus I/O Modules

	max. load	min. load
per module (total for all relay contacts)	19...29 VAC, 1...29 VDC 3 A resistive or inductive, $\cos \varphi \geq 0.6$, no capacitive load, protected by fuse F4	–
per normally open contact	19...29 VAC, 1...29 VDC 0.5 A resistive or inductive, $\cos \varphi \geq 0.6$, no capacitive load	>50 mW, 0.05 A res./ind., $\cos \varphi \geq 0.6$

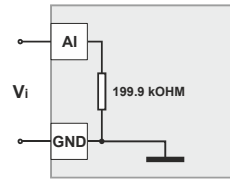

Fig. 29. Analog input high impedance (input circuit for voltage input for active sensors)

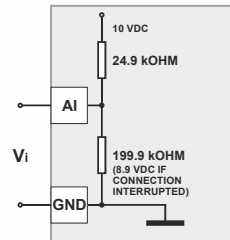

Fig. 30. Analog input impedance setpoint (input circuit for NTC10kΩ, NTC20kΩ, wall module setpoint)

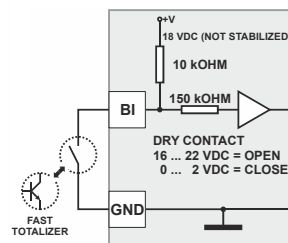

Fig. 31. Configuration of a binary input as a fast totalizer

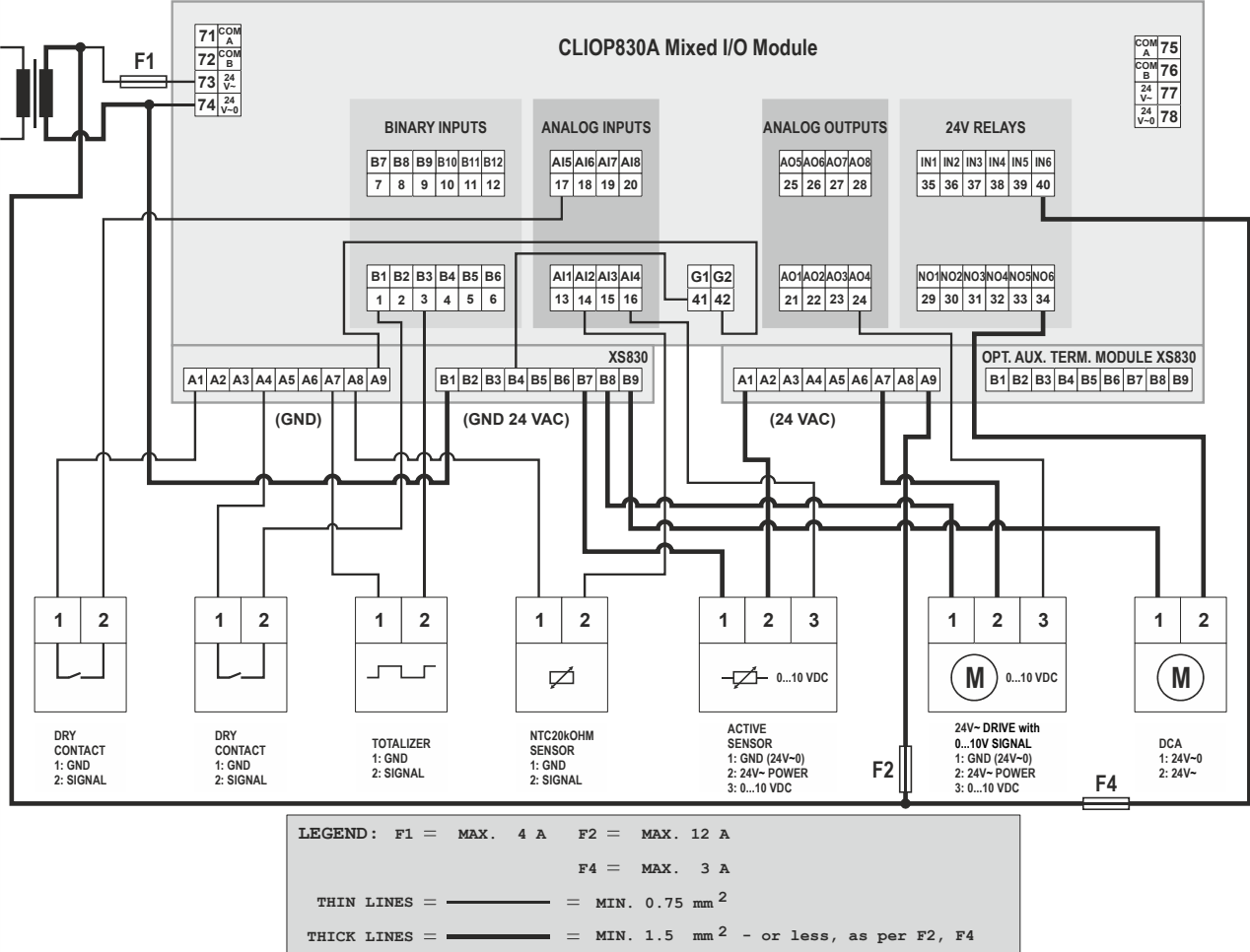

Fig. 32. CLIOP830A mixed Panel Bus I/O Module, wiring example: Actuators

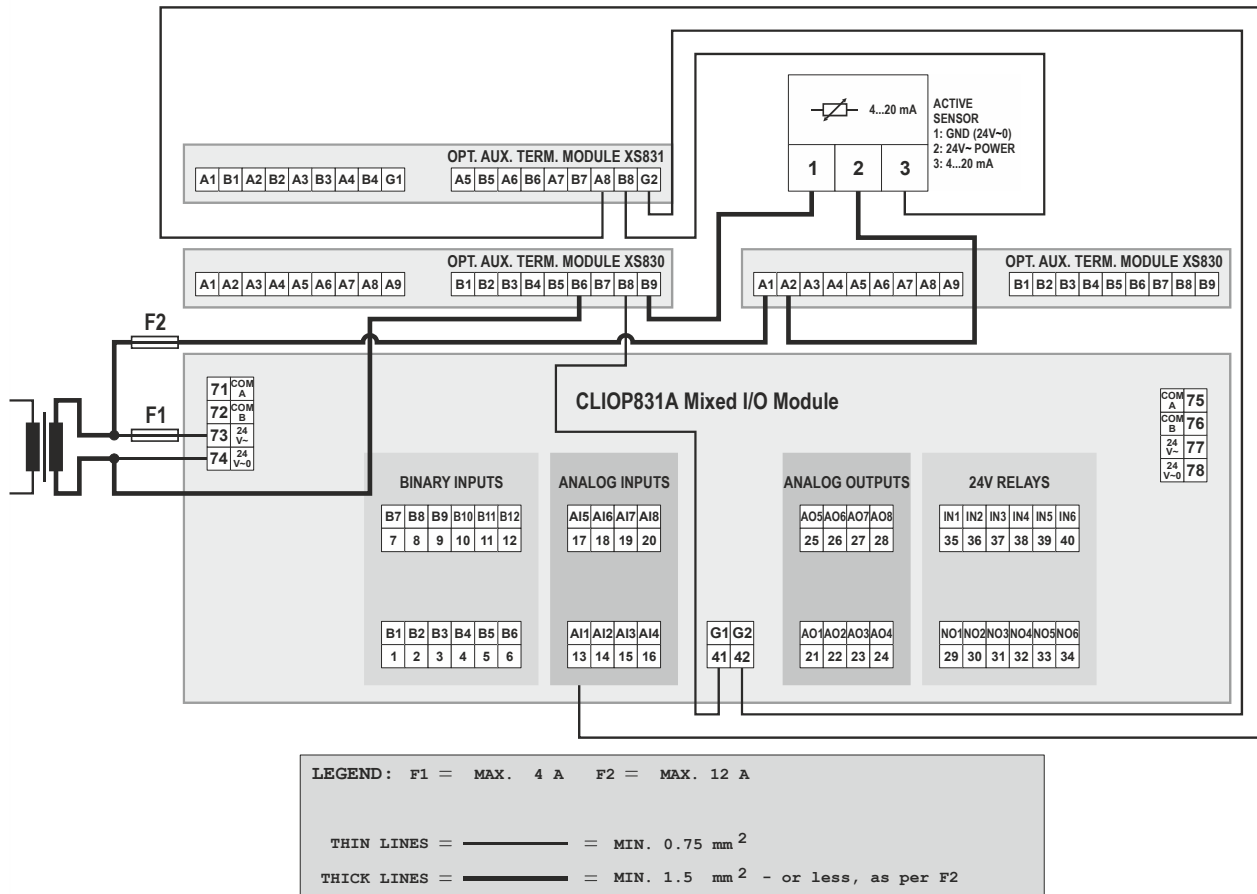

Fig. 33. CLIO831A mixed Panel Bus I/O Module, wiring example: Current inputs

Approvals, Certifications, and Standards

Approvals and Certifications

- CE-approved
- Conforms to EN 60730-1 and EN 60730-2-9
- Investigated according to United States Standard UL916 (USL-listed) as well as according to Canadian National Standard(s) C22.2 (CNL-listed)

Classification according to EN60730-1

Environmental conditions: For use in home (residential, commercial, and light-industrial) environments
 Pollution degree: Class 2
 Protection against shock: Class II
 Software class: Class A
 Overvoltage category: II

Classification according to EN60529

(Degree of Protection Provided by Enclosures)
 Classification: IP20

Ambient Environmental Limits

Operating temperature: 0 ... +50 °C at 5...93% r.H.
 Storage temperature: -20 ... +70 °C at 5...93% r.H.
 Humidity: 5 ... 93% r.h. non-condensing

Current Requirement and Heat Dissipation

The Panel Bus I/O Modules are equipped with highly-efficient switching power supplies which provide for relatively uniform power consumption over a wide range of supply voltages (see Table 8). The specific heat dissipation inside the modules amounts to less than 2 W for all models.

Table 8. Current requirements of Centraline Panel Bus I/O Modules

devices powered	supply voltage	
	24 VAC	24 VDC
CLIOP821A	130 mA	80 mA
CLIOP822A, CLIOPR822A	150 mA	90 mA
CLIOP823A, CLIOL823A	180 mA	130 mA
CLIOP824A, CLIOPR824A, CLIOPR825A	140 mA	80 mA
CLIOP830A, CLIOP831A	200 mA	95 mA

Mechanical

Housing dimensions (H x W x D)

The pluggable CentraLine I/O Modules (mounted on Terminal Sockets) all have the dimensions: 110 X 90 X 93 mm (see also Fig. 34 on page 25).

The CLIOP830A mixed Panel Bus I/O module has the dimensions: 216 X 110 X 93 mm (see also Fig. 35 on page 25).

The CLIOP831A mixed Panel Bus I/O module has the dimensions: 216 X 110 X 61 mm (see also Fig. 36 on page 26).

Housing Material

Plastic, flame-retardant

Mounting Methods

DIN-rail mounting (e.g. in control cabinet).

Calculated Lifetime of Weakest Components

MTBF ≥ 13.7 years (under typical operating conditions)

Sensor Characteristics

The following sensor characteristics do not include failures due to:

- sensor failures;
- wiring resistance or wiring failures;
- misreadings due to a meter connected to measure resistance or voltage at the input.

For more-detailed values, see section "Appendix 3: Sensor Characteristics" of the CentraLine I/O Modules – Installation & Commissioning Instructions (EN1Z-0973GE51).

Table 9. BALCO 500

Temp. [°C]	Resistance [Ω]	Terminal voltage [V]
-20.0	415	0.164
0.0	453	0.179
20.0	493	0.194
40.0	535	0.210
60.0	579	0.227
80.0	625	0.245
100.0	673	0.263
120.0	724	0.283

Table 10. NTC 20 kOhm

Temp. [°C]	Resistance [kΩ]	Terminal voltage [V]
-20.0	221.0	8.08
0.0	70.2	6.76
20.0	25.3	4.75
40.0	10.2	2.81
60.0	4.52	1.51
80.0	2.17	0.792
100.0	1.11	0.425
120.0	0.61	0.238

Table 11. Pt 1000

Temp. [°C]	Resistance [Ω]	Terminal voltage [V]
-20.0	922	0.357
0.0	1000	0.386
20.0	1078	0.415
40.0	1155	0.443
60.0	1232	0.471
80.0	1309	0.499
100.0	1385	0.527
120.0	1461	0.554

Table 12. Ni1000TK5000

Temp. [°C]	Resistance [Ω]	Terminal voltage [V]
-20.0	913.5	0.354
0.0	1000.0	0.386
20.0	1090.7	0.420
40.0	1185.7	0.455
60.0	1285.4	0.491
80.0	1390.1	0.529
100.0	1500.0	0.568
120.0	1615.4	0.609

Table 13. NTC 10 kOhm

Temp. [°C]	Resistance [kΩ]	Terminal voltage [V]
-20.0	97.073	7.241
0.0	32.650	5.299
20.0	12.490	3.207
40.0	5.327	1.724
60.0	2.488	0.898
80.0	1.258	0.478
100.0	0.680	0.265

Table 14. Pt 3000

Temp. [°C]	Resistance [kΩ]	Terminal voltage [V]
-20.0	3.090	1.104
0.0	3.266	1.160
20.0	3.440	1.214
40.0	3.613	1.267
60.0	3.784	1.319
80.0	3.954	1.370
100.0	4.122	1.420
120.0	4.289	1.469

Dimensions

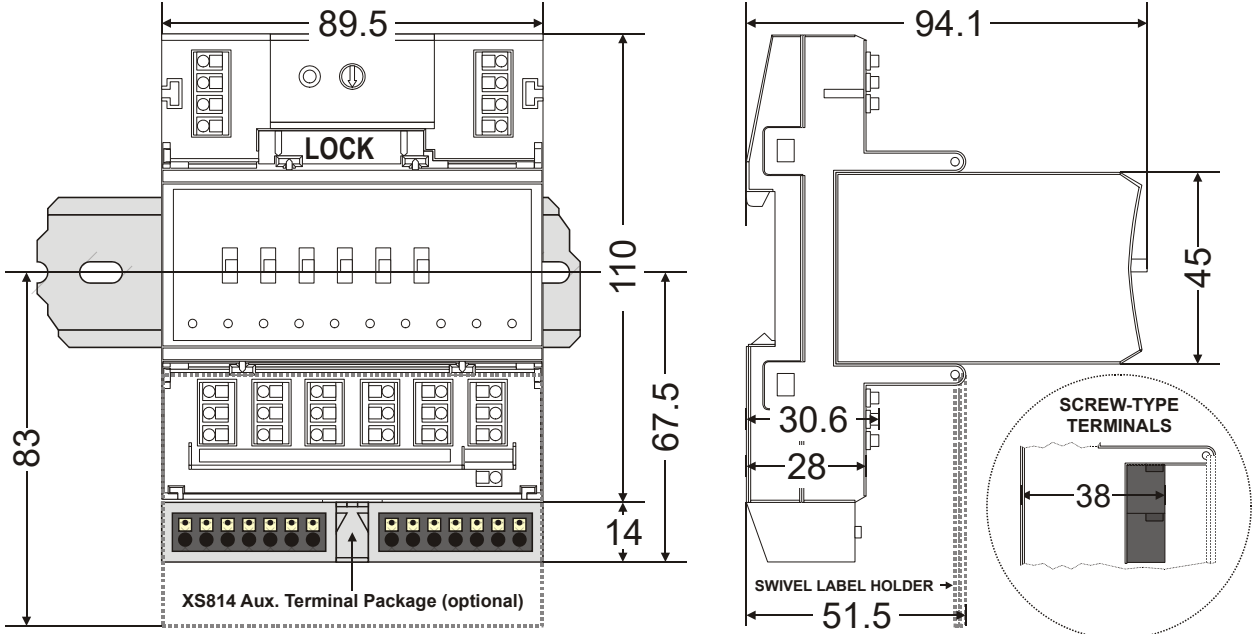

Fig. 34. CentralLine Panel Bus I/O Modules (example shows Manual Overrides), incl. Terminal Socket, outside dimensions (in mm)

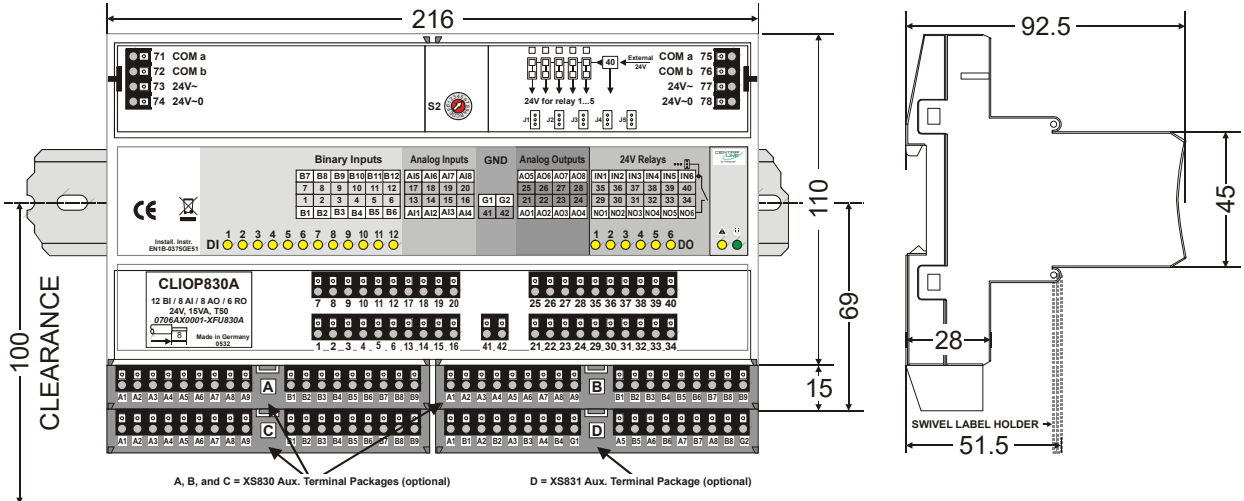

Fig. 35. CLIO830A mixed Panel Bus I/O module (shown with 4 auxiliary terminal packages), dimensions (in mm)

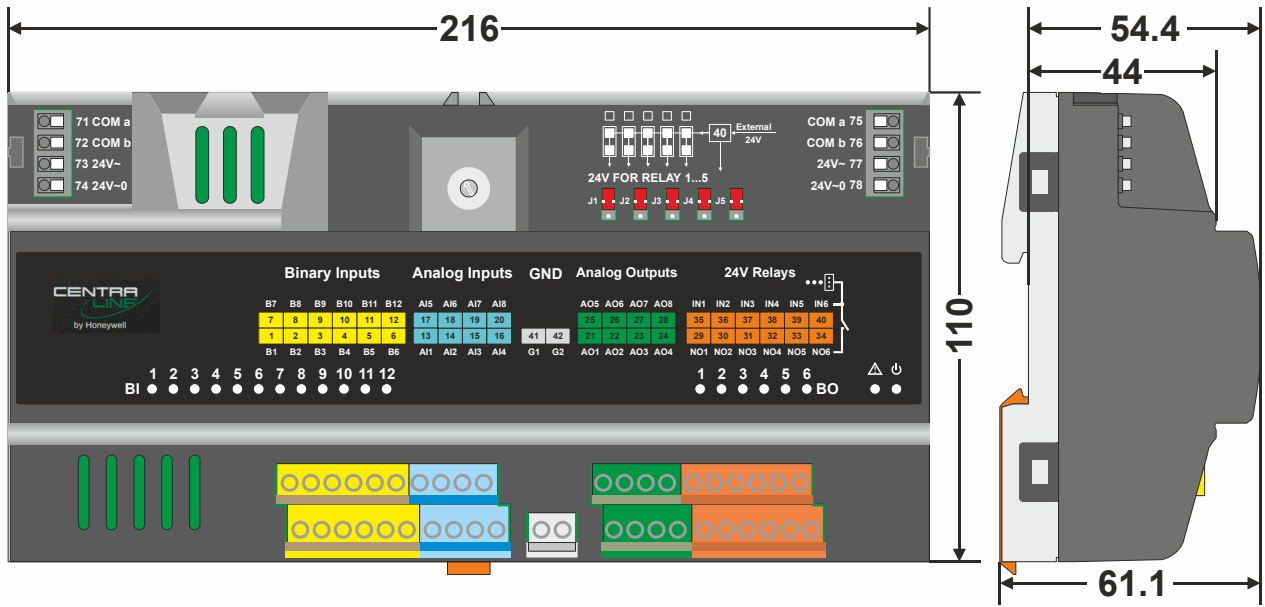

Fig. 36. CLIO831A mixed Panel Bus I/O module, dimensions (in mm)

Manufactured for and on behalf of the Connected Building Division of Honeywell Products and Solutions S.A.R.L., Z.A. La Pièce, 16, 1180 Rolle, Switzerland by its Authorized Representative:

Centraline
 Honeywell GmbH
 Böblinger Strasse 17
 71101 Schönaich, Germany
 Phone +49 (0) 7031 637 845
 Fax +49 (0) 7031 637 740
info@centraline.com
www.centraline.com

Subject to change without notice
 EN0Z-0979GE51 R0119

