



## GENERAL

EAGLE is Centraline's Ethernet-based, freely-programmable Building Automation controller offering a combination of the major open standards of today's building industry: BACnet<sup>®</sup>, LONWORKS<sup>®</sup>, Modbus, and M-Bus.

It demonstrates Centraline's full commitment to reducing total installed cost and total building lifecycle cost for building investors and building operators.

As a native BACnet<sup>®</sup> Building Controller (B-BC), EAGLE integrates into any 3<sup>rd</sup>-party BACnet<sup>®</sup> system with low and predictable effort.

Furthermore, EAGLE (in combination with the IF-LON) is a full LONWORKS<sup>®</sup> controller. This gives the benefit of making use of Centraline's complete LONWORKS<sup>®</sup> product portfolio, which is unique in the building industry.

EAGLE can host a huge variety of building management applications, be it traditional heating, ventilation, and air conditioning (HVAC) applications, energy management functions, including optimum start/stop, night purge, and maximum load demand, supervisory functions for lighting, sun-blind, heat and energy metering and many other applications.

By virtue of its "peer-to-peer" concept, EAGLE is not dependent upon the availability of superordinate centrals or application network controllers.

EAGLE seamlessly integrates into Centraline's ARENA AX and SymmetrE<sup>®</sup> front-ends.

## 3RD-PARTY SOFTWARE LICENSES

This product contains software provided by third parties. See also EAGLE Controller – Third-Party Software Licenses (Product Literature No.: EN2Z-0991GE51).

## FEATURES

- **Reduced the total installed cost:**  
Existing standard Ethernet/LAN infrastructure is used for communication between EAGLE controllers, 3<sup>rd</sup>-party BACnet<sup>®</sup> controllers, and BACnet<sup>®</sup> front-ends. Costs are further reduced by the flexible and optional use of onboard I/Os and Panel Bus I/Os.
- **Universal operation:**  
Via Internet browser, the EAGLE can be operated from any place, from any PC connected to the (EAGLE) network! An integrated web-server allows local and remote operation by standard browsers.

### NETWORK SECURITY

When operating the EAGLE in IP networks, either private (e.g., VPN) networks must be used or protection against the open Internet (e.g., by means of external firewalls) must be ensured. See "Network Security" on pg. 6.

- **Reduced cost for service, operation and maintenance:**  
Maintenance or upgrade of Operator Interface Software is superfluous because it resides in EAGLE, itself (single-source principle).
- **Vendor independence:**  
Communication is based on the following international standards: BACnet/IP (ISO 16484-5); BACnet MS/TP (ISO 16484-5); LONWORKS (ISO 14908); Modbus RTU Master; M-Bus (EN 1434-3).
- **Trending:**  
125 datapoints can be trended, with 10,000 trend entries (samples) each.
- **Fast application control:**  
Four selectable control loop priorities (multitasking), selectable control loop cycle times, and event-driven switching tables allow for tailored and highly effective applications control.
- **Reliable control performance:**  
Embedded LINUX ensures reliable, independent, and secure operation, especially for systems with Internet access.
- **Embedded e-mail/SMS alarming:**  
Configurable e-mail alarming options allow alarms to be sent (via network or Internet-DSL connection) to e-mail accounts and thus also to mobile phones.
- **Centraline CARE tool:**  
Allows re-use of existing applications and application macros, enables highly effective application generation, and supports online application debugging.
- **Flexible mounting options:** Mounting onto wall or onto panel back wall, into panel door, onto panel rail, and into sub-panels (fuse boxes).

## OPERATOR INTERFACE

EAGLE is operated via a standard browser. By default, an integrated web-server provides all operation pages for a full browser-based operation.

Through the consequent use of software standards, any PC platform can be used as an operator interface (client), including laptops, desktops PCs, or touch screen PCs for direct flush mounting into electrical panel doors (IP65).

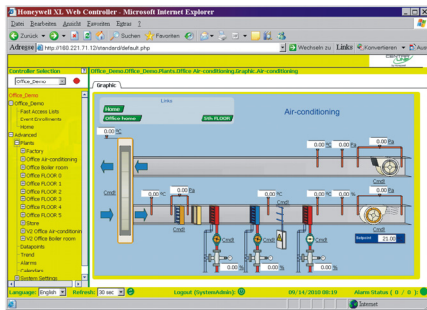

Fig. 1. EAGLE "Homepage" Example

## Programming

EAGLE is freely programmable using the graphic CARE Engineering Tool and is thus ideal for all Building Control and Building Management tasks.

## Password Protection

EAGLE allows the definition of up to 6 user levels. Each user level can be assigned different read and write rights. Several users with individual passwords can be defined for each user level.

## COMMUNICATION PROTOCOLS

### BACnet/IP – ISO 16484-5 and EN 13321-1

Communication with other EAGLE controllers, 3<sup>rd</sup>-party BACnet devices, Honeywell Enterprise Buildings Integrator™ and SymmetrE front-ends, and with 3<sup>rd</sup>-party BACnet front-ends is based on the international BACnet Protocol.

EAGLE conforms to the BACnet Building Controller (B-BC) profile.

For details on the BACnet Interoperability, see the EAGLE Protocol Implementation Conformance Statement (PICS) (Product Literature No.: ENOZ-0978GE51).

### BACnet MS/TP – ISO 16484-5 and EN 13321-1

Communication with other BACnet controllers (Honeywell and 3<sup>rd</sup>-party) is based on the international BACnet Protocol.

Optionally, one or both of the onboard RS485 interfaces can be used for communication via BACnet MS/TP.

### LonTalk® - ISO 14908

Optionally, communication with physical I/O modules, with room and zone controllers, and with CentralLine PANTHER, TIGER, and LION controllers can utilize LonTalk.

With the IF-LON, a Free Topology Transceiver (FTT-10A or FT-X1) allows a communication speed of 78 Kbaud. Max.

cable lengths are 320 m to 2,200 m, depending upon the given wiring topology.

By default, the IF-LON comprises the LonMark® node object, plus application-specific LONWORKS objects.

### Modbus RTU Master

Optionally, either of the two onboard RS485 interfaces (but not both simultaneously) can be used for communication via Modbus RTU.

See also EAGLE – Installation & Commissioning Instructions (Product Literature No.: EN1Z-0970GE51) for details.

### M-Bus – EN 1434-3

Optionally, M-Bus communication is possible via the onboard RS232 interface.

See also EAGLE – Installation & Commissioning Instructions (Product Literature No.: EN1Z-0970GE51) for details.

### Panel Bus

Optionally, one or both of the onboard RS485 interfaces can be used for Panel Bus communication with CentralLine Panel Bus I/O modules. The firmware of the Panel Bus I/O modules is automatically updated by the EAGLE controller.

### HTTP

EAGLE provides two operating options:

- Internet browsers having a resolution of 800x600 pixels or higher.
- Internet Explorer for WIN CE with a resolution of 320x240 pixels, optimized for Excel Touch or other 5.7" touch panels.

For supported web browsers, please consult the Software Release Bulletin.

### HTTPS

Secure web browser communication is supported for web access via standard web browsers.

### SMTP

The secure Simple Mail Transfer Protocol is used for e-mail alarming via network and Internet-DSL connection.

### SSH

For firmware and application up-/download as well as for service access, the "Secure Shell" protocol is used, providing authentication and encryption. Via SSH, product- or plant-related technical literature can be downloaded into EAGLE for later retrieval.

### Remote LonWorks Access

EAGLE's remote network interface allows the EAGLE's FTT LONWORKS network to be accessed via the EAGLE's IP connection. TCP3830 port is used for this purpose.

## BUS AND PORT CONNECTIONS

### WARNING

#### Risk of electric shock or equipment damage!

- ▶ Do not touch any live parts in the cabinet!
- ▶ Disconnect the power supply before making connections to or removing connections from terminals of the EAGLE Controller or Panel Bus I/O modules.
- ▶ Do not reconnect the power supply until you have completed installation.
- ▶ Due to the risk of short-circuiting (see Fig. 8), it is strongly recommended that the EAGLE controller be supplied with power from a dedicated transformer. However, if the EAGLE controller is to be supplied by the same transformer powering other controllers or devices (e.g., the PW M-Bus Adapter), care must be taken to ensure that correct polarity is observed.
- ▶ Observe the rules regarding electrostatic discharge.

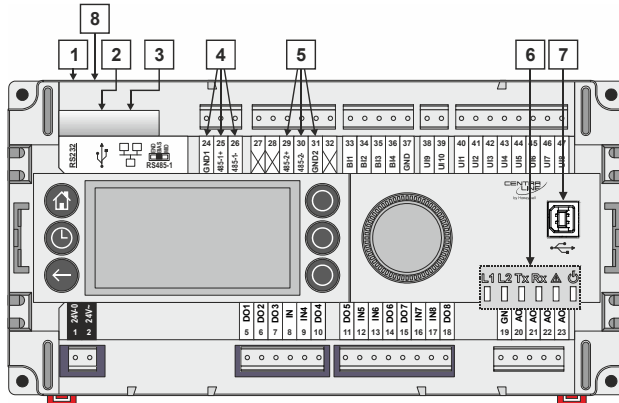

Fig. 2. Models with built-in HMI (top view)

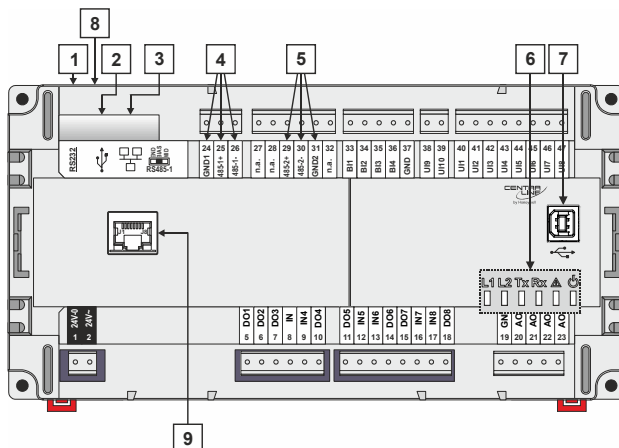

Fig. 3. Models without built-in HMI (top view)

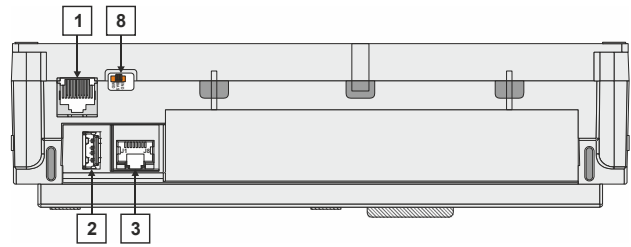

Fig. 4. All models (side view)

#### Legend

- 1 RS232 / RJ45 socket (for M-Bus connection and factory debugging)
- 2 USB 2.0 Host Interface (for connection of the IF-LON); max. 500 mA, high speed
- 3 Ethernet / RJ45 socket (for BACnet IP communication) – all models except CLEA2014B21 and CLEA2014B31; 10/100 Mbit/s; 1 "activity" LED
- 4 RS485-1\* (isolated; for BACnet MS/TP, Panel Bus, or Modbus RTU Master communication)
- 5 RS485-2\* (non-isolated; for BACnet MS/TP, Panel Bus, or Modbus RTU Master communication)
- 6 LEDs
- 7 USB 2.0 Device Interface (for connection to CARE / XW-Online and web browsers, CL-Touch, or other 3<sup>rd</sup>-party touch panels)
- 8 Three-position slide switch (for setting bias and termination resistance of RS485-1)
- 9 RJ45 socket for connection of CLEAHMI21 External HMI – CLEA2000B31, CLEA2014B31, CLEA2014B32, CLEA2026B31, only

\* Modbus RTU Master communication is possible on either one of the two RS485 interfaces, but not on both of them concurrently.

**NOTE:** In the case of the CLEA2014B21 and CLEA2014B31, at least one of the two RS485 interfaces must be assigned to BACnet MS/TP. The other RS485 interface can then be assigned to either Panel Bus, Modbus, or BACnet MS/TP.

### WARNING

#### Risk of electric shock or equipment damage!

- ▶ It is prohibited to connect any of the RJ45 sockets of the EAGLE Controller to a so-called PoE-enabled device ("Power over Ethernet").

## M-Bus Connection

The EAGLE controller supports M-Bus Master functionality via its onboard RS232 / RJ45 socket. It uses standard PW3/PW20/PW60 converters to connect to the M-Bus devices.

## Wiring Topology

Max. bus length is 1000 meters.

M-Bus devices are connected to the bus cable in parallel.

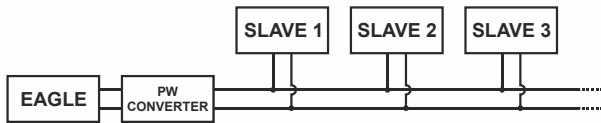

Fig. 5. Allowed M-Bus wiring topology

**Cables**

See section "M-Bus Connection" in EAGLE Controller – Installation & Commissioning Instructions (EN1Z-0970GE51). Use shielded, twisted pair cable J-Y-(St)-Y 2 x 2 x 0,8.

**Shielding**

Shielding is especially recommended when the M-Bus cable is installed in areas with expected or actual electromagnetic noise. Avoiding such areas is to be preferred.

Use shielded, twisted pair cable J-Y-(St)-Y 2 x 2 x 0,8 and connect the shield to a noise-free earth ground – only once per M-Bus connection.

**M-Bus Repeaters**

The M-Bus can be extended to 1,000 meters, depending on the baud rate, and provided that the electrical limitations are observed. For details refer to the Installation & Commissioning Instructions (EN1Z-0970GE51).

For bus length extension, M-Bus repeaters can be used, but have not been tested by Honeywell. Hence, it is the responsibility of the installing / commissioning personnel to ensure proper functioning.

**M-Bus Master Specifications**

**Physical Layer**

RS232 to PW3/PW20/PW60

Physical connector: RS232 / RJ45 socket (see Fig. 4)

Cable order number: XW586

Communication rates: 300, 2,400, and 9,600 Baud are supported, individually per M-Bus slave.

Max. no. of devices: 60 (excluding the EAGLE controller)

Cable and wiring specifications: See EAGLE – Installation & Commissioning Instructions (EN1Z-0970GE51).

**Address Range**

M-Bus slaves can have a primary address between 1 and 250.

**Measurement Cycle**

Individually per M-Bus slave, the measurement cycle can be configured from 1 to 604,800 sec (i.e., 1 second to 7 days).

**M-Bus Communication Failure Indication**

As soon as the EAGLE runs an application which includes M-Bus points, it will try to communicate with the M-Bus devices.

If an M-Bus slave does not respond to a message from the EAGLE controller, the EAGLE controller will repeat the message several times. If the M-Bus slave still does not respond, the EAGLE will stall the messaging to this M-Bus slave for 60 seconds. After these 60 seconds, the EAGLE

controller will again address the M-Bus slave. This cycle will be repeated endlessly as long as there is no answer. If the EAGLE does not receive any response for ≥ 5 minutes, the mapped datapoint will go to the communication failure condition.

**M-Bus "Unreliable\_Other" Indication**

Each M-Bus device has a status with 8 bits. The following bits are used to set all mapped datapoints from this M-Bus device to the "Unreliable\_Other" condition.

Table 1. Bits used to set all mapped datapoints

Bit	Meaning	Result
0	app.-specific	ignored
1	app.-specific	ignored
2	low power	reliability flag set to Unreliable_Other
3	perm. error	reliability flag set to Unreliable_Other
4	temp. error	reliability flag set to Unreliable_Other
5	manuf.-spec.	ignored
6	manuf.-spec.	ignored
7	manuf.-spec.	ignored

Additionally, each data record has a function field which can indicate the data as "Value with Error." In this case, the corresponding datapoint (not all datapoints) is set to the "Unreliable\_Other" condition.

**NOTE:** The "Unreliable\_Other" condition will result in the corresponding datapoint value being set to the last valid value. This means that the value from the M-Bus device is not shown in the datapoint; rather, an old value is shown.

**Open Source Library for M-Bus**

The libmbus library is a component of RaditexSCADA that is published as open source, and it is free for anyone to use as long as due credit is given to RaditexSCADA and Raditex Control in derivative work based on the libmbus library.

Copyright (c) 2010-2011, Raditex Control AB. All rights reserved.

Redistribution and use in source and binary forms, with or without modification, are permitted provided that the following conditions are met:

- Redistributions of source code must retain the above copyright notice, this list of conditions, and the following disclaimer.
- Redistributions in binary form must reproduce the above copyright notice, this list of conditions, and the following disclaimer in the documentation and/or other materials provided with the distribution.
- Neither the name of the Raditex Control AB nor the names of its contributors may be used to endorse or promote products derived from this software without specific prior written permission.

THIS SOFTWARE IS PROVIDED BY THE COPYRIGHT HOLDERS AND CONTRIBUTORS "AS IS," AND ANY EXPRESS OR IMPLIED WARRANTIES, INCLUDING, BUT NOT LIMITED TO, THE IMPLIED WARRANTIES OF MERCHANTABILITY AND FITNESS FOR A PARTICULAR PURPOSE ARE DISCLAIMED. IN NO EVENT SHALL THE COPYRIGHT HOLDER OR CONTRIBUTORS BE LIABLE FOR ANY DIRECT, INDIRECT, INCIDENTAL, SPECIAL, EXEMPLARY, OR CONSEQUENTIAL DAMAGES (INCLUDING, BUT NOT LIMITED TO, PROCUREMENT OF SUBSTITUTE GOODS OR SERVICES; LOSS OF USE, DATA, OR PROFITS; OR BUSINESS INTERRUPTION) HOWEVER CAUSED AND ON ANY THEORY OF LIABILITY, WHETHER IN CONTRACT, STRICT LIABILITY, OR TORT (INCLUDING NEGLIGENCE OR OTHERWISE) ARISING IN ANY WAY OUT OF THE USE OF THIS SOFTWARE, EVEN IF ADVISED OF THE POSSIBILITY OF SUCH DAMAGE.

## Modbus Connection

The EAGLE controller can function as a Modbus Master. In general, the RS485 wiring rules must be followed.

### Wiring Topology

Only daisy-chain wiring topology is allowed.

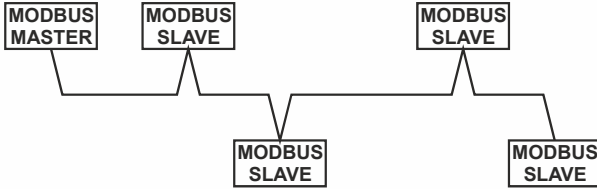

Fig. 6. Allowed Modbus wiring topology

Other wiring topologies (e.g., star wiring, or mixed star wiring and daisy chain wiring) are prohibited; this is to avoid communication problems of the physical layer.

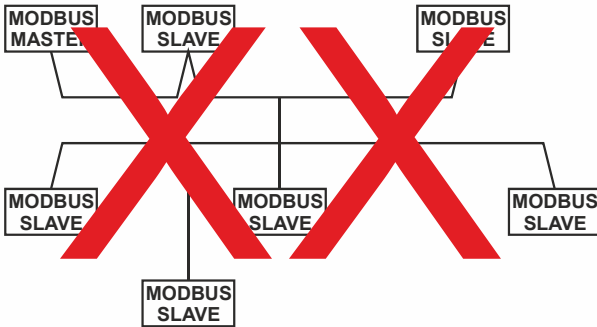

Fig. 7. Prohibited Modbus wiring topology (example)

### Cables

See section "EIA 485 Cable Specifications" in EAGLE Controller – Installation & Commissioning Instructions (EN1Z-0970GE51).

Use shielded, twisted pair cable J-Y-(St)-Y 2 x 2 x 0,8.

You **must** use three wires:

- One wire for D1 = Modbus +
- One wire for D0 = Modbus –
- One wire for the signal common

When using one pair for D1 and D0 and one wire of another pair for the signal common, CAT5 cable may also be used.

For connection details, see EAGLE Controller – Installation & Commissioning Instructions (EN1Z-0970GE51).

### Shielding

Shielding is especially recommended when the Modbus cable is installed in areas with expected or actual electromagnetic noise. Avoiding such areas is to be preferred.

Use shielded, twisted pair cable J-Y-(St)-Y 2 x 2 x 0,8 and connect the shield to a noise-free earth ground – only once per Modbus connection.

### RS485 Repeaters

RS485 repeaters are possible, but have not been tested by Honeywell. Hence, it is the responsibility of the installing / commissioning personnel to ensure proper functioning.

**NOTE:** Each Modbus segment requires its own line polarization and line termination.

### Modbus Master Specifications

#### Modbus Compliance

As per the Modbus standard, the EAGLE controller is a conditionally compliant "regular" Modbus device.

The EAGLE controller differs from an unconditionally compliant "regular" Modbus device in that it does not support communication rates of 1.2, 2.4, and 4.8 kBaud (because these communication rates are not market-relevant).

#### Physical Layer

2-wire serial line RS485 (EIA-485) (with additional common)

Communication rates: 9.6, 19.2, 38.4, 57.6, 76.8, and 115.2 kBaud supported.

Max. number of devices: 32

Cable and wiring specifications: See EAGLE – Installation & Commissioning Instructions (EN1Z-0970GE51).

#### Communication Mode

Modbus Master.

#### Transmission Mode

RTU (Remote Terminal Unit)

#### Address Range

Modbus slaves can have an address between 1 and 65000.

Discrete Inputs, Coils, Input Registers and Holding Registers can have an address between 1 and 65534.

#### Function Codes

The following function codes are supported:

Table 2. Supported function codes

function code (hex)	function
02	Read Discrete Inputs
01	Read Coils
05	Write Single Coil
04	Read Input Register
03	Read Holding Register
06	Write Single Register
10	Write Multiple Registers

#### Exception Codes

Upon reception of any of the following exception codes, datapoints of the EAGLE application will show "no response."

Table 3. Supported exception codes

exception code (hex)	function
01	illegal function
02	illegal data address
03	illegal data value
04	slave device failure
05	acknowledge
06	slave device busy



### Register Sizes

The following Register sizes are supported:

- 16-bit Registers for Discrete inputs, Coils, Input Registers, and Holding Registers
- 32-bit Registers for Input Registers and Holding Registers.

### Data Types

The following data types are supported:

- Discrete Inputs:
  - BOOL
- Coils:
  - BOOL
- Input Registers:
  - BOOL
  - INT16, UINT16
  - INT32, UINT32
  - FLOAT
- Holding Registers:
  - BOOL
  - INT16, UINT16
  - INT32, UINT32
  - FLOAT
  - 32-bit floating points can be transmitted as two consecutive 16-bit registers.

### Byte and Word Order Transmission

- Most Significant Byte First (default)
- Lower Significant Byte First
- Most Significant Word first (default)
- Lower Significant Word first

### Bit Unpack

The EAGLE allows direct reading of single bits of an Input Register or of a Holding Register into a data-point.

In typical situations in which several different status bits of a Modbus slave's Register need to be read and linked into the EAGLE application, this allows for very efficient application engineering.

### Number of Stop Bits

One and two stop bits are supported.

### Error Checking Mode

Parity checking: No parity, even parity, odd parity.

Frame checking: Cyclical redundancy checking (CRC).

### Life Check of Modbus Slaves

The EAGLE checks the Modbus every 15 seconds for lost Modbus slaves.

### Message Timeout

20 msec ... 5000 msec.

### Modbus Slaves Measurement Cycle

- "Live check repeat count": default = 3, range = 0...10
- "Live check": default = 2, range = 1...20 sec
- "Live check if offline": default = 15, range = 2...60 sec
- "Poll Rate": default = 1, range = 0...6000 sec

### Modbus Communication Failure Indication

As soon as the EAGLE runs an application which includes mappings to Modbus registers, it will try to communicate with these Modbus registers.

If a Modbus slave does not respond to a message from the EAGLE controller, the EAGLE controller will repeat the message as per the settings described in section "Modbus Slaves Measurement Cycle".

If, after "Life check repeat count" times, the Modbus slave has still not responded to the message from the EAGLE controller, the Modbus point will go into the "fault" state.

---

 **WARNING**

---

## NETWORK SECURITY

Honeywell hereby expressly states that the EAGLE is not inherently protected against cyber attacks from the Internet and that it is therefore intended solely for use in private, protected networks.

Unprotected Internet connections can expose the EAGLE to cyber attacks from third parties who can then damage it and connected facility components or cause them to malfunction, or who can misuse it for illegal purposes for which the operator may then be held liable.

When directly connected to the Internet, the EAGLE automatically becomes a potential target for cyber attacks.

Corresponding protective measures are therefore essential if safe and reliable operation is to be ensured.

If it is not necessary for the EAGLE to be accessible from the Internet, the EAGLE should be isolated from the Internet via a suitable firewall.

If it is necessary for the EAGLE to be accessible from the Internet (e.g., in order to perform remote maintenance), the use of a coded VPN connection is indispensable. Suitable VPN routers are available from numerous third-party manufacturers in a wide variety of designs, for operation at 230 V or 24 V.

For details, see also EAGLE Networking Whitepaper (Product Literature No.: EN2Z-0992GE51).

# CONTROLLER SPECIFICATIONS

## General

Table 4. Controller specifications

<b>Ambient temperature</b>	0 ... 40 °C (wall-mounting) 0 ... 50 °C (cabinet/door mounting)
<b>Storage temperature</b>	-20 ... +70 °C
<b>Humidity</b>	5 ... 95% r.h. non-condensing
<b>Dimensions</b>	See Fig. 10 and Fig. 12.
<b>Degree of protection</b>	IP20 (mounted on walls, with two accessory MVC-80-AC1 covers) IP30 (mounted in cabinet doors, with accessory MVC-80-AC2)
<b>Fire class</b>	V0
<b>Shock protection</b>	Class II
<b>Pollution degree</b>	2
<b>Installation</b>	Class 3
<b>Rated impulse voltage</b>	330 V for SELV, 2500 V for relay outputs
<b>Overvoltage category</b>	II
<b>Automatic action</b>	Type 1.C
<b>Software class</b>	Class A
<b>Ball-pressure test temperature</b>	housing parts >75°C terminals >125°C

## Electrical Data

Table 5. Electrical data

<b>Power supply</b>	19 ... 29 VAC, 50/60 Hz, or 20 ... 30 VDC
<b>Power consumption</b>	typically dc: 5 W; max. 6 W typically ac: 9 VA; max. 11 VA
<b>Heat dissipation</b>	Max. 6 W at dc power supply max. 11 W at ac power supply
<b>Current consumption</b>	typically dc: 210 mA; max. 240 mA typically ac: 370 mA; max. 410 mA

Due to the risk of short-circuiting (see Fig. 8), it is strongly recommended that the EAGLE controller be supplied with power from a dedicated transformer. However, if the EAGLE controller is to be supplied by the same transformer powering other controllers or devices (e.g., the PW M-Bus Adapter), care must be taken to ensure that correct polarity is observed.

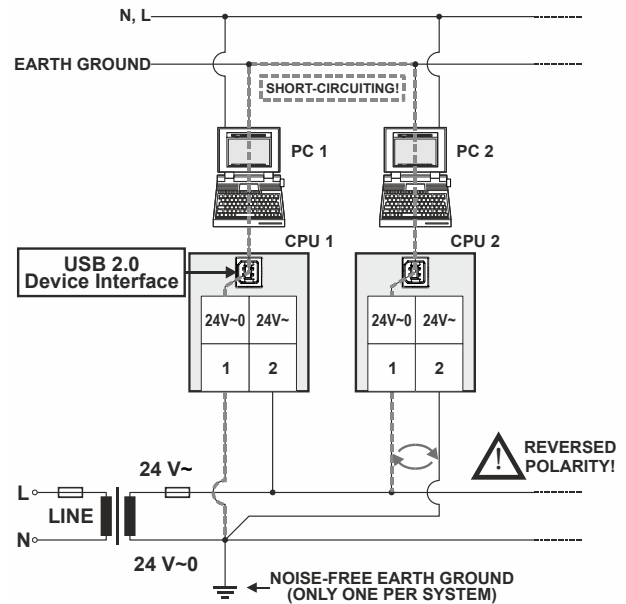

Fig. 8. Incorrect polarity → SHORT-CIRCUITING!

## Mechanical Data

**Housing Dimensions (L x W x H):** 215.5 x 110 x 61 mm

**Housing Material:** ABS blend; flame retardant V0

**Weight:** 0.6 kg (without packaging)

**Protection Class:** IP 20

## CPU

### Processor

- ARM 9 32-bit processor, 450 MHz

### Operating System

- LINUX

### Memory

- 128 MB DDR2-RAM
- 1 GB Flash Memory

### Real-Time Clock

- accuracy:  $\pm 2$  minutes per year (at, typically, 25 °C)
- buffered typically for 72 h by gold capacitor

## Standards, Approvals, etc.

- Device meets BTL, AMEV AS-A, EN 60730-1, EN 60730-2-9, UL60730, and UL916.
- The device complies with Ethernet Protocol versions IEEE 802.3.
- The device supports BACnet IP and BACnet MS/TP communications as per ANSI / ASHRAE 135-2010.

## MMI

The CLEA2014B21, CLEA2014B22, CLEA2026B21, and CLEA2000B21 incorporate a built-in user interface (HMI) featuring the following components:

- one LCD Display (1);
- six operating keys (2);
- one Rotate&Push Button (3); and
- six LEDs (4)

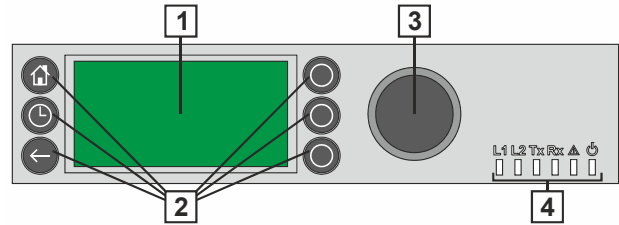

Fig. 9. EAGLE Controller user interface (HMI)

The LCD display is the graphic interface presenting items for application-specific system information, operator entries, and menus of functions. The LCD display can show max. five lines of alphanumeric text with max. 20 characters per line.

The backlight of the LCD is switched on once an operating key or the rotate&push button is pressed. The backlight is switched off if any of the operating keys or the button is not used for 2 minutes.

The six operating keys consist of three fixed-function keys (left) and three soft keys (right).

The Rotate&Push button is used to navigate through menus and lists; to highlight items (menu, list, option, value, command symbol), and to adjust options (ON, OFF, etc.) and values (temperature in °C, etc.).

## Mounting

The EAGLE Controller is suitable for mounting as follows:

- ▶ in cabinets;
- ▶ in fuse boxes conforming with standard DIN43880, and having a slot height of max. 45 mm;
- ▶ on walls (using accessory MVC-80-AC1 covers).
- ▶ in cabinet front doors (using accessory MVC-80-AC2);



Extra Parts

Table 6. Extra parts

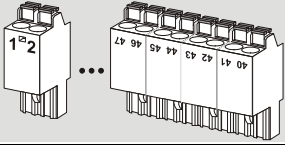
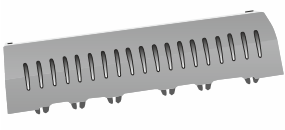
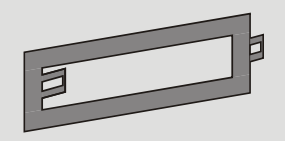
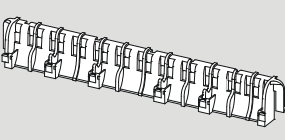
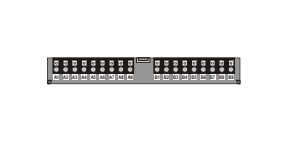
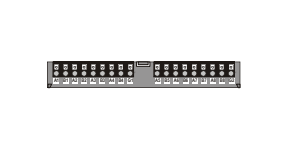
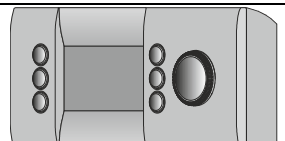
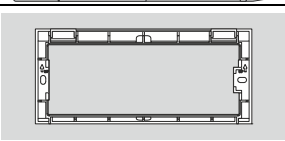
	order number	description
	<p><b>TPU-11-01</b></p>	<p>Removable terminal plugs, push-in type; complete set of 3 plugs (for terminals 1, 2, 24-32); for the CLEA2000Bxx.</p>
	<p><b>TPU-45-01</b></p>	<p>Removable terminal plugs, push-in type; complete set of 9 plugs (for terminals 1 - 47); for the CLEA2014Bxx and CLEA2026Bxx.</p>
	<p><b>MVC-80-AC1</b></p>	<p>Terminal cover (color: RAL9011); package of 10; for EAGLE Controllers.</p>
	<p><b>MVC-80-AC2</b></p>	<p>Front door mounting accessory (color: RAL9011); package of 10; for EAGLE Controllers.</p>
	<p><b>MVC-40-AC3</b></p>	<p>Strain relief; package of ten; for EAGLE Controllers.</p>
	<p><b>XS830</b></p>	<p>Set of ten packages. Each Auxiliary Terminal Package consists of two groups of nine internally connected push-in terminals, for distributing signals / power. For the Mixed Panel Bus I/O Module and the EAGLE Controller, only. Please refer to Centraline I/O Modules - Installation &amp; Commissioning Instructions (EN1Z-0973GE51) for more information.</p>
	<p><b>XS831</b></p>	<p>Set of ten packages. Each Auxiliary Terminal Package consists of two groups of four pairs of push-in terminals (each with a 499 Ω resistor), for converting 0...20 mA signals into 0...10 VDC signals, and one push-in ground terminal per group. Please refer to Centraline I/O Modules - Installation &amp; Commissioning Instructions (EN1Z-0973GE51) for more information.</p>
	<p><b>CLEAHMI21</b></p>	<p>External HMI with LCD display which derives needed electrical energy from the EAGLE controller. Suitable for connection to the RJ45 socket on the front of the CLEA2000B31, CLEA2014B31, CLEA2014B32, and CLEA2026B31.</p>
	<p><b>CLEAHMI-BASE</b></p>	<p>Base for mounting the CLEAHMI21 onto walls and magnetic surfaces, and for hand-held use.</p>

## MODELS

- CLEA2000B21: with HMI, without onboard I/Os, and with 600 I/Os in total\*; TPU-11-01; CLEAHMI21 not connectable
- CLEA2000B31: without onboard I/Os, with 600 I/Os in total\*; TPU-11-01; with RJ45 socket for CLEAHMI21 External HMI
- CLEA2014B21: with HMI, 14 onboard I/Os, and 52 I/Os in total\*; TPU-45-01; CLEAHMI21 not connectable
- CLEA2014B22: with HMI, 14 onboard I/Os, and 52 I/Os in total\*; TPU-45-01; CLEAHMI21 not connectable
- CLEA2014B31: with 14 onboard I/Os and 52 I/Os in total\*; TPU-45-01; with RJ45 socket for CLEAHMI21 External HMI
- CLEA2014B32: with 14 onboard I/Os and 52 I/Os in total\*; TPU-45-01; with RJ45 socket for CLEAHMI21 External HMI
- CLEA2026B21: with HMI, 26 onboard I/Os, and 600 I/Os in total\*; TPU-45-01; CLEAHMI21 not connectable
- CLEA2026B31: with 26 onboard I/Os and 600 I/Os in total\*; TPU-45-01; with RJ45 socket for CLEAHMI21 External HMI

\*I/Os in total include onboard I/Os, I/Os via Panel Bus, I/Os via Modbus, I/Os via M-Bus, and I/Os via LONWORKS Bus.

**Table 7. Overview of models**

feature	description	max. cable length	order no.								
			CLEA2014B21 <sup>(1)</sup>	CLEA2014B31 <sup>(1)</sup>	CLEA2014B22	CLEA2014B32	CLEA2026B21	CLEA2026B31	CLEA2000B21	CLEA2000B31	
UI	NTC10kΩ / NTC20kΩ / 0...10V / slow BI	400 m	4	4	4	4	8	8	-	-	
	NTC10kΩ / NTC20kΩ / 0...10V fix pull-up / slow BI	400 m	-	-	-	-	2	2	-	-	
BI	open = 24 V / closed 2.0 mA / totalizer 15 Hz	400 m	4	4	4	4	4	4	-	-	
AO	0..11 V (max. 1 mA)	400 m	2	2	2	2	4	4	-	-	
BO	Relay N.O. contact	400 m	3	3	3	3	4	4	-	-	
	Relay N.O. contact (high in-rush)	400 m	1	1	1	1	1	1	-	-	
	Relay N.O. contact with one common	400 m	-	-	-	-	3	3	-	-	
bus interfaces	RS485-1, isolated, BACnet MS/TP, Panel Bus, or Modbus RTU Master communication	1200 m <sup>(2)</sup>	1	1	1	1	1	1	1	1	
	RS485-2, non-isolated, BACnet MS/TP, Panel Bus, or Modbus RTU Master communication	1200 m <sup>(2)</sup>	1	1	1	1	1	1	1	1	
	Ethernet Interface	e-mail communication, browser access	100 m	-	-	1	1	1	1	1	1
		BACnet IP communication	100 m	-	-	1	1	1	1	1	1
	USB 2.0 Device Interface (as Network Interface)	3 m	1	1	1	1	1	1	1	1	
	USB 2.0 Host Interface (max. 500 mA)	3 m	1	1	1	1	1	1	1	1	
RS232 M-Bus communication via PW3 / PW20 / PW60 converters	1000 m <sup>(2)</sup>	1	1	1	1	1	1	1	1	1	
user interface	HMI with graphic LCD	--	X	-	X	-	X	-	X	-	
	Fast Access buttons	--	6	-	6	-	6	-	6	-	
	push and turn button	--	1	-	1	-	1	-	1	-	
LEDs	power LED (green)	--	1	1	1	1	1	1	1	1	
	status LED (red, controllable by firmware)	--	1	1	1	1	1	1	1	1	
	applications-specific LED L1 (yellow)	--	1	1	1	1	1	1	1	1	
	LED L2 (reserved)	--	1	1	1	1	1	1	1	1	
	bus status LEDs (for isolated RS485-1 interface)	--	2	2	2	2	2	2	2	2	
Socket for CLEAHMI21	RJ45 socket for connection of CLEAHMI21 External HMI	5 m	--	X	--	X	--	X	--	X	

<sup>(1)</sup> In the case of the CLEA2014B21 and CLEA2014B31, at least one of the two RS485 interfaces must be assigned to BACnet MS/TP. The other RS485 interface can then be assigned to either Panel Bus, Modbus, or BACnet MS/TP.

<sup>(2)</sup> Depending upon baud rate. For max. cable lengths, refer to the EAGLE – Installation & Commissioning Instructions (EN1Z-0970GE51).

**DIMENSIONS**

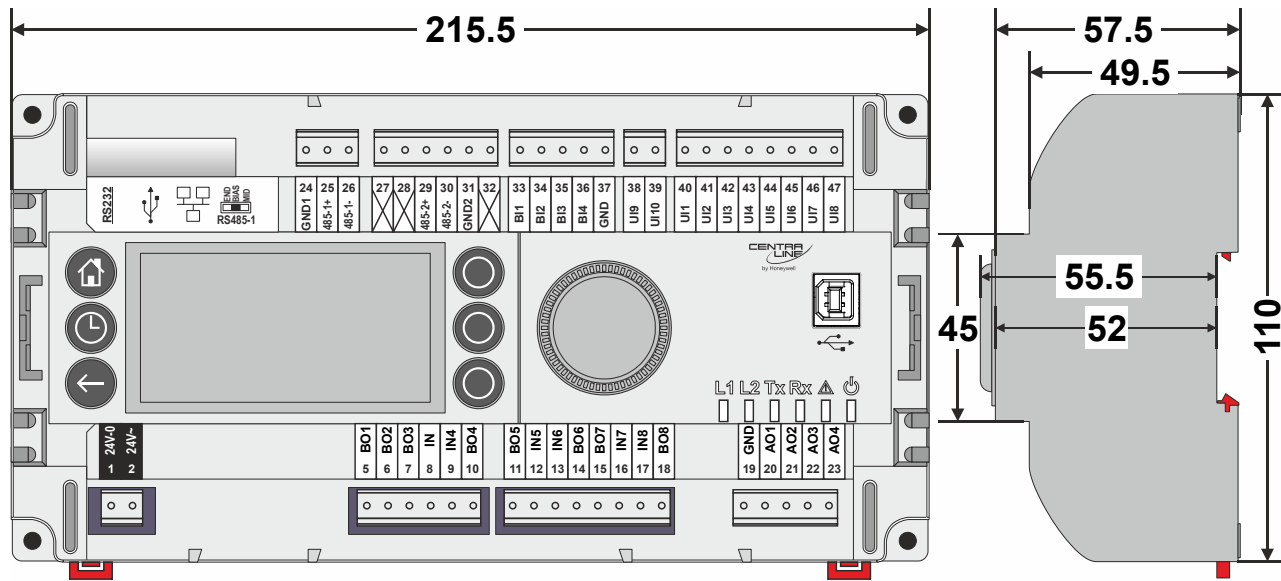

**Fig. 10. EAGLE Controller with built-in HMI, dimensions (in mm)**

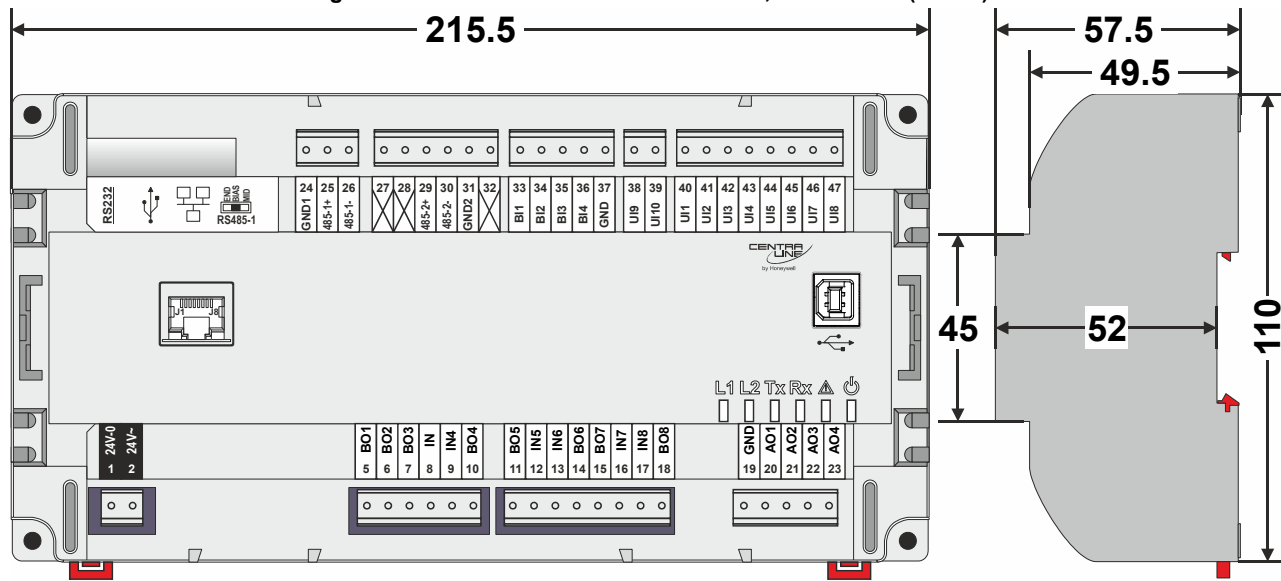

**Fig. 11. EAGLE Controller with RJ45 socket for connection of CLEAHMI21 External HMI, dimensions (in mm)**

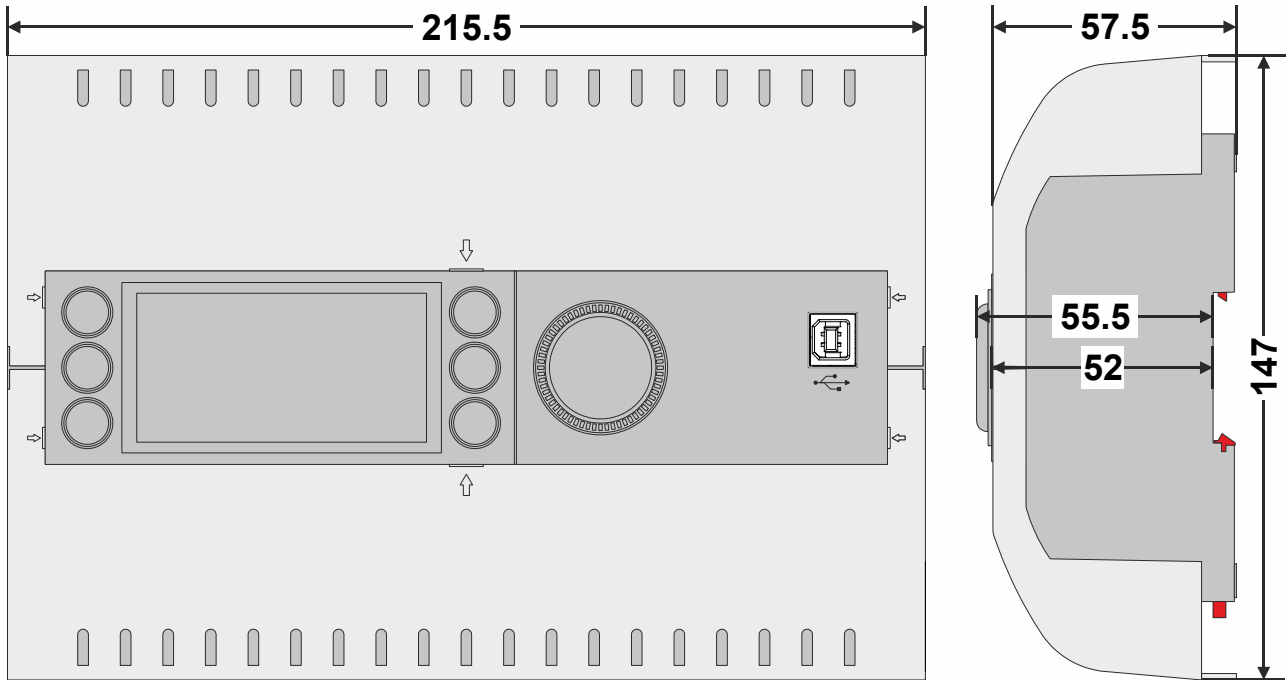

Fig. 12. EAGLE Controller with built-in HMI (with MVC-80-AC1), dimensions (in mm)

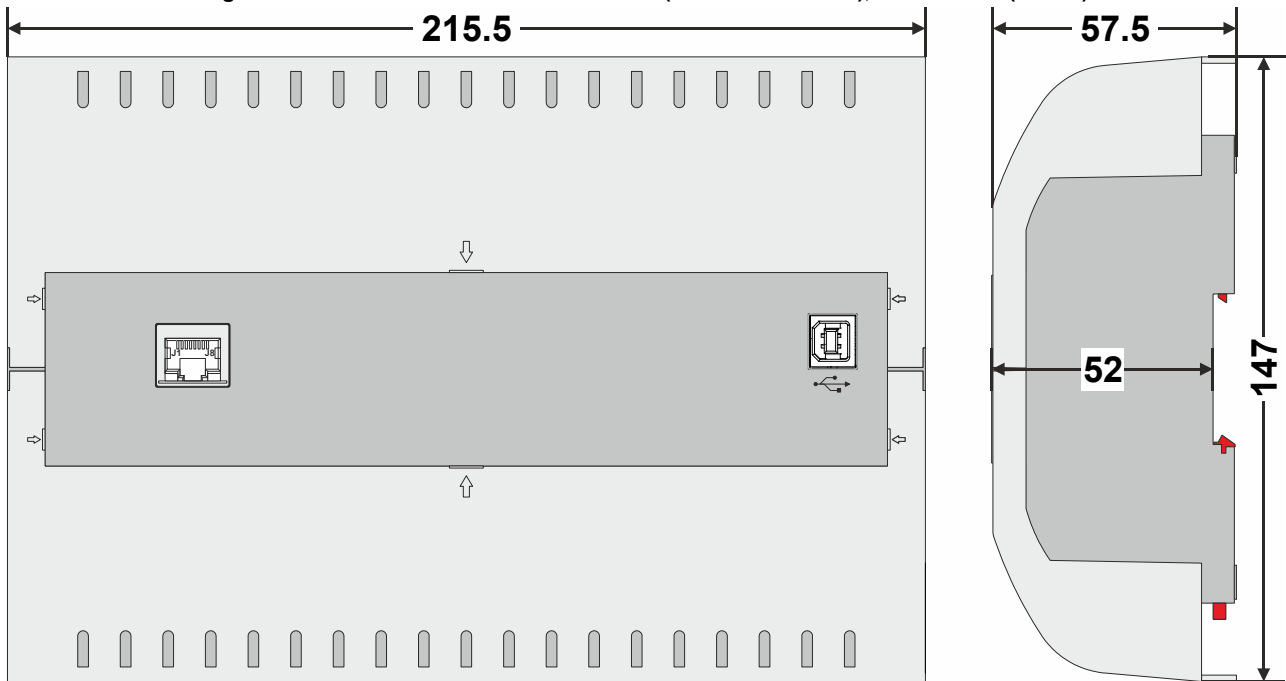

Fig. 13. EAGLE Controller with RJ45 socket for CLEAHMI21 External HMI (with MVC-80-AC1), dimensions (in mm)

**NOTE:** Use of the covers (MVC-80-AC1) obstructs access to the Ethernet and USB 2.0 Host Interfaces and RS232 socket.

Manufactured for and on behalf of the Environmental & Energy Solutions Division of Honeywell Technologies Sàrl, Rolle, Z.A. La Pièce 16, Switzerland by its Authorized Representative:

CentraLine  
 Honeywell GmbH  
 Böblinger Strasse 17  
 71101 Schönaich, Germany  
 Phone +49 (0) 7031 637 845  
 Fax +49 (0) 7031 637 740  
[info@centraline.com](mailto:info@centraline.com)  
[www.centraline.com](http://www.centraline.com)

Subject to change without notice  
 EN0Z-0970GE51 R0918

