

VF00, VF01, VF10, VF20

IMMERSION AND AIR-DUCT TEMPERATURE SENSORS

PRODUCT DATA



GENERAL

These immersion and air-duct temperature sensors can be employed for hot and cold water as well as for air-duct applications in systems using Ni 1000, Pt 1000, NTC 10k, or NTC 20k temperature sensing elements.

The sensors with a stainless steel immersion well are also suitable for registering potable water temperature.

FEATURES

- Pt 1000, Ni 1000, NTC 10k, or NTC 20k temperature sensing element
- Wide sensing range
- High accuracy
- Choice of three different probe lengths: 65, 150, and 300 mm
- Models available with either IP54 or IP65 rating
- Bayonet ¼ turn cover screws for fast installation
- External mounting holes, no need to remove cover

SENSOR SPECIFICATION

Nominal value

Pt 1000 / Ni 1000	1000 Ω at 0 °C (32 °F)
NTC 10k	10 kΩ at 25 °C (77 °F)
NTC 20k	20 kΩ at 25 °C (77 °F)

Accuracy

Pt 1000 (IEC751 Class B)	±0.3 K at 0 °C (32 °F)
Ni 1000	±0.4 °C at 0 °C (32 °F)
NTC 10k, NTC 20k	±0.2 K at 25 °C (77 °F)

Sensitivity

Pt 1000	≈ 3.85 Ω / K (linear)
Ni 1000	≈ 6.18 Ω / K (non-linear)
NTC 10k	-440 Ω / K at 25 °C (non-linear)
NTC 20k	≈ -934.5 Ω / K at 25 °C (non-lin.)

NOTE: See also Temperature Sensors / Temperature-Resistance Curves - Product Data (EN0B-0476GE51).

Time constant < 30 s (using brass / stainless steel immersion well)

Electrical connection

Connection terminals for 2 x 1.5 mm² cable
Cable gland M16x1.5, UL 94-V2

Ambient limits (housing)

Storage temperature -30...+70 °C (-22...+158 °F)
Humidity 5...95% rh, non-condensing

Safety (terminal box)

Protection class IP54 / IP65 as per EN 60529

Flame retardant

UL94-V0 rated plastic enclosure
T_{max} = 120 °C (enclosure)

Dimensions

See section "Dimensions" below.

IMMERSION WELL SPECIFICATION

Operating temperature	-40 ... +150 °C
Humidity	5...95% rh, non-condensing
Material	
WB	brass, nickel-plated tube: CuZn37-CW508L (Ms63) nipple: CuZn39Pb3 (Ms58)
WS	stainless steel tube: 1.4571 / 316Ti nipple: 1.4404 / 316L

Sensor Models

OS-no.	length mm (inch) L _{PROBE}	IP rating	sensor type	sensing temperature limits (probe)	immersion well (ordered separately)
VF00-1B54NW	150 (5.91)	IP54	Pt 1000	-40...+150 °C	WB150, WS150
VF00-1B65NW	150 (5.91)	IP65	Pt 1000	-40...+150 °C	WB150, WS150
VF00-3B54NW	300 (11.81)	IP54	Pt 1000	-40...+150 °C	WB300, WS300
VF00-3B65NW	300 (11.81)	IP65	Pt 1000	-40...+150 °C	WB300, WS300
VF00-5B54NW	65 (2.56)	IP54	Pt 1000	-40...+150 °C	WB50, WS50
VF00-5B65NW	65 (2.56)	IP65	Pt 1000	-40...+150 °C	WB50, WS50
VF01-1B54NW	150 (5.91)	IP54	Ni 1000	-40...+150 °C	WB150, WS150
VF01-1B65NW	150 (5.91)	IP65	Ni 1000	-40...+150 °C	WB150, WS150
VF01-3B54NW	300 (11.81)	IP54	Ni 1000	-40...+150 °C	WB300, WS300
VF01-3B65NW	300 (11.81)	IP65	Ni 1000	-40...+150 °C	WB300, WS300
VF01-5B54NW	65 (2.56)	IP54	Ni 1000	-40...+150 °C	WB50, WS50
VF01-5B65NW	65 (2.56)	IP65	Ni 1000	-40...+150 °C	WB50, WS50
VF10-1B54NW	150 (5.91)	IP54	NTC 10k	-40...+110 °C	WB150, WS150
VF10-1B65NW	150 (5.91)	IP65	NTC 10k	-40...+110 °C	WB150, WS150
VF10-3B54NW	300 (11.81)	IP54	NTC 10k	-40...+110 °C	WB300, WS300
VF10-3B65NW	300 (11.81)	IP65	NTC 10k	-40...+110 °C	WB300, WS300
VF10-5B54NW	65 (2.56)	IP54	NTC 10k	-40...+110 °C	WB50, WS50
VF10-5B65NW	65 (2.56)	IP65	NTC 10k	-40...+110 °C	WB50, WS50
VF20-1B54NW	150 (5.91)	IP54	NTC 20k	-40...+150 °C	WB150, WS150
VF20-1B65NW	150 (5.91)	IP65	NTC 20k	-40...+150 °C	WB150, WS150
VF20-3B54NW	300 (11.81)	IP54	NTC 20k	-40...+150 °C	WB300, WS300
VF20-3B65NW	300 (11.81)	IP65	NTC 20k	-40...+150 °C	WB300, WS300
VF20-5B54NW	65 (2.56)	IP54	NTC 20k	-40...+150 °C	WB50, WS50
VF20-5B65NW	65 (2.56)	IP65	NTC 20k	-40...+150 °C	WB50, WS50

Immersion Well Models (sold separately)

OS-no.	material	length mm (inch) L _{WELL}	connection	P _{max}	max. flow speed*
WS50	stainless steel	50 (1.97)	R1/2" / ISO, PN25	25 bar	30 m/s
WB50	brass, nickel-plated	50 (1.97)		13 bar	26 m/s
WS150	stainless steel	135 (5.31)		25 bar	7.5 m/s
WB150	brass, nickel-plated	135 (5.31)		13 bar	5 m/s
WS300	stainless steel	285 (11.22)		25 bar	2 m/s
WB300	brass, nickel-plated	285 (11.22)		13 bar	1.2 m/s

*At flow speeds above 1 m/s, the temperature profile in the water is flat, thus reducing the required immersion depth.

Flanges (compatible with all devices; sold separately)

OS-no.	description
LF-MF	Mounting flange for air-duct use, BULK – 10 pieces

DIMENSIONS

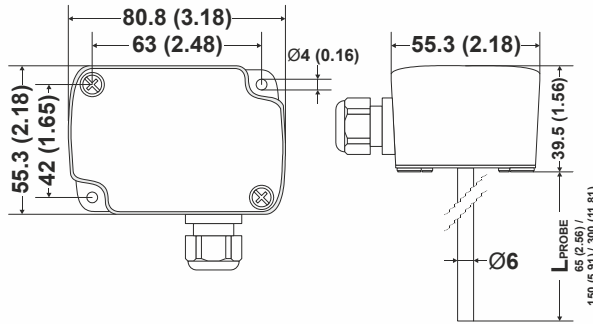
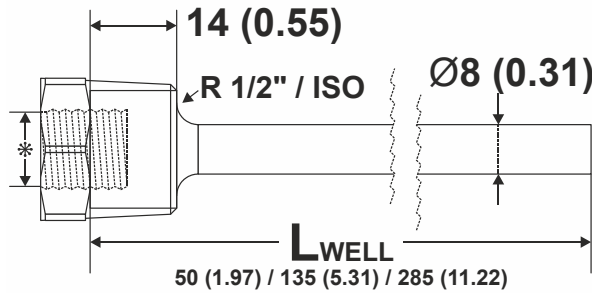

Fig. 1. Housing, dimensions in mm (inches)



* THREAD FOR CABLE GLAND M12x1.5
ACCESSIBLE AFTER REMOVING SPRING

Fig. 2. Immersion well, dimensions in mm (inches)

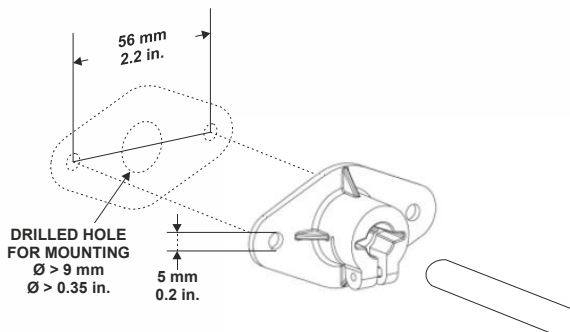

Fig. 3. Flange mounting on duct (mm, inches)

INSTALLATION

wiring run	max. length
Sensor to controller	200 m (660 ft)

Offset due to wire resistance per 10 m of distance from sensor to controller, when using the VF00 (Pt 1000):

type of wire	temperature offset Pt 1000
0.5 mm ² (AWG20)	0.18 °C (0.324 °F)
1.0 mm ² (AWG17)	0.09 °C (0.162 °F)
1.5 mm ² (AWG15)	0.06 °C (0.108 °F)

NOTE: Use shielded wiring in areas with high EMI.
Keep 15 cm (5.9") minimum distance between sensor lines and 230 Vac power lines.

ELECTRICAL CONNECTION

The wiring of the temperature sensor must be in accordance with the overall wiring circuit diagram.
The terminals are not polarized. Thus, connecting the wires in reverse will not result in any malfunction.

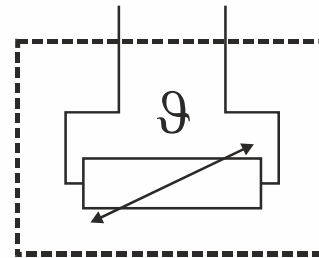

Fig. 4. VF00, VF01, VF10, VF20 wiring

Home and Building Technologies

Honeywell GmbH
Böblinger Strasse 17
71101 Schönaich, Germany
Phone +49 (0) 7031 637 01
Fax +49 (0) 7031 637 740
<http://ecc.emea.honeywell.com>