

HVAC230-xxx-xxT

SMARTDRIVE HVAC INVERTERS FOR 230V 3~ IT NETWORKS

PRODUCT DATA



GENERAL

The SmartDrive HVAC inverter is an easy-to-use solution for all Heating, Ventilation and Air Conditioning applications in which speed control of the motor can be applied. The software also offers extensive possibilities for stand-alone PID control and Pump and Fan Cascade control. The drive is suitable for induction and permanent magnet motors.

Main applications in HVAC:

- Pumps
- Fans
- Compressors

HARDWARE FEATURES

- Compact size
- Multilanguage HMI with text display
- Increased cabling space
- Stress removal and 360° grounding possibility for cabling inside the unit – no need for cable glands
- Configured as standard for IT networks
- Integrated DC Choke to comply with EN 61000-3-12
- Varnished printed circuit boards as standard to maximize reliability
- Wide input and output connection possibilities
- Several integrated field buses:
 - Ethernet(IP): BACnet IP, Modbus TCP/IP
 - RS485(MS/TP): BACnet MS/TP, Modbus RTU, N2
- Wide range of I/O expansion and field bus option boards

- Integrated real-time clock with battery back-up for timed functions and fault time stamps
- USB connection to PC with SMARTDRIVE-USBC cable

SOFTWARE FEATURES

- 30s Start-Up Wizard
- Mini wizards: PID, cascade control, and resonance sweep wizards
- Very silent motor operation with high switching frequency
- Over-temperature ride-through
- Power ride-through
- Trip-free operation with maintenance/safety switch between the inverter and the motor
- Configurable auto-reset
- RTO – Ramp Time Optimizer
- PID controller with advanced functionality: sleep mode, pump soft fill, feed forward, pressure loss compensation, etc.
- Extra PID controller for controlling other devices
- Pump and Fan Cascade (PFC) controller with full auto-change functionality

SPECIFICATIONS

Mains Connection

Input voltage U_{in}	208...240 Vac (-10...+10%), 3~
Input frequency	47...66 Hz
Connection to mains	Once per minute or less

Motor Connection

Output voltage	0 - U_{in} , 3~
Output current	I_N : Continuous output current with maximum +40 °C ambient temperature, overloadability 1.1 x I_N (1min/10min)

Output frequency	0...320 Hz
Frequency resolution	0.01 Hz

Control Characteristics

Control method	Frequency control U/f
Switching frequency	1.5...16 kHz; default 6 kHz (1.1-30 kW) default 4 kHz (18.5-55 kW)
Field weakening point	8...320 Hz
Acceleration time	0.1...3000 sec
Deceleration time	0.1...3000 sec

Ambient Conditions

Operating temperature -10 °C (no frost)...+40 °C
ambient: rated loadability I_N (also higher ambient with derating)

Storage temperature -40...+70 °C

Air Quality

Tested according to: IEC 60068-2-60 Flowing mixed gas corrosion test, Method 1 (H₂S [hydrogen sulfide] and SO₂ [sulfur dioxide])

Designed according to: Chemical vapors: IEC 60721-3-3, unit in operation, class 3C2
Mechanical particles: IEC 60721-3-3, unit in operation, class 3S2

Altitude 100% load capacity (no derating) up to 1000 m
1% derating for each 100 m above 1000 m; max. 4500 m
Allowed voltage for I/O signals:
Up to 2000 m: max 240V
2000-4500 m: max 120V

Relative humidity 0...95% RH, non-condensing, non-corrosive, no dripping water

Mechanical vibration 5...150 Hz
EN 50178, EN 60068-2-6 Displacement amplitude 1 (peak) mm at 5...15.8 Hz
Max acceleration amplitude 1 G at 15.8...150 Hz

Mechanical shock UPS Drop Test (for applicable UPS weights)
EN 50178, IEC 68-2-27 Storage and shipping: max 15 g, 11 ms (in package)

Enclosure class IP21 and IP54 models available
NOTE! IP54 fulfilled only when the HMI is in place

Electromagnetic Compatibility (EMC)

RFI Immunity EN 61800-3 1st and 2nd environment (industrial and public electrical networks)

RFI Emissions EN 61800-3 for IT networks

Harmonics emissions EN 61000-3-12

Safety

EN 61800-5-1 CE

UL508C UL, cUL

(See unit nameplate for more detailed approvals.)

Control Connections

Analog inputs 2 inputs as standard selection for mA or V with dip switches:
0(2)...+10 V (R_i = 200 kΩ)
0(4)...20 mA (R_i = 250 Ω)
Resolution 0.1%, accuracy ±1%, short-circuit protected

Digital inputs 6 inputs as standard with positive or negative logic:
0...5 V = "0"
15...30 V = "1"
R_i = min. 5 kΩ

Motor thermistor input R_{TRIP}=4.7 kΩ (PTC); measuring voltage 3.5 V

Aux. DC-voltage input 24 Vdc, ±10%; can be used for power backup of the control unit

Analog output 1 output as standard selection for mA or V with dip-switches:
0(2)...+10 V
0(4)...20 mA
Load <500 Ω, resolution 0,1%, accuracy ±2%, short-circuit protected

Digital outputs 2 programmable relay outputs (NO/NC) as standard.
Max. switching load: 24 Vdc / 8 A, 250 Vac / 8 A or 125 Vdc / 0.4 A
Min. switching load: 5 V / 10 mA

24V aux. voltage outputs 2 outputs: +24 Vdc, ±10%, max. load 250 mA, short-circuit protected

10V ref. voltage output +10 Vdc, +3%, max. load 10 mA

Protections		Motor overload	YES
Overvoltage	456 Vdc (~340 Vac) in HVAC230	Motor stall	YES
Undervoltage	Depends on supply voltage ($0.8775 \cdot V_{IN}$) 160 Vdc (~120 Vac) with 230 V V_{IN}	<i>(Fan/pump blocked)</i>	
		Motor underload	YES
Overcurrent	Trip limit $4.0 \cdot I_N$ instantaneously	<i>(Pump dry / Belt broken detection)</i>	
Earth-fault	YES	Short-circuit of +24V and +10V ref. voltages	YES
Inverter over temperature	YES	Pump soft fill timeout	YES
Input phase loss	YES		
Output phase loss	YES		

PRODUCT IDENTIFICATION CODE

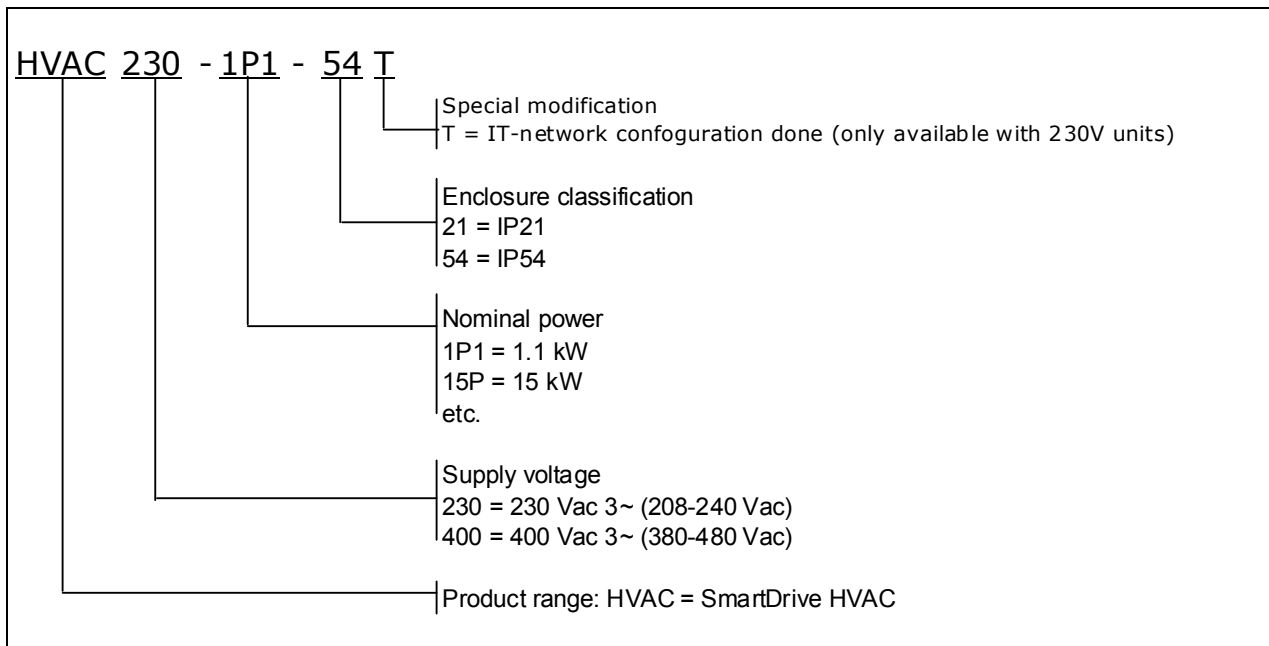

Fig. 1. Product Identification Code

MODELS

Mains voltage 230 V 3~ IT networks (208-240 V), 50/60 Hz							
Inverter type *)	Motor nominal shaft power 230V supply 40°C P[kW]	Loadability		Enclosure class	Mechanical size	Dimensions WxHxD [mm]	Weight [kg]
		Rated continuous current I _N [A]	10% overload current [A]				
HVAC230- P55 -xxT	0.55	3.7	4.1	IP21/54	MR4	128x328x190	6
HVAC230- P75 -xxT	0.75	4.8	5.3	IP21/54	MR4	128x328x190	6
HVAC230- 1P1 -xxT	1.1	6.6	7.3	IP21/54	MR4	128x328x190	6
HVAC230- 1P5 -xxT	1.5	8	8.8	IP21/54	MR4	128x328x190	6
HVAC230- 2P2 -xxT	2.2	11	12.1	IP21/54	MR4	128x328x190	6
HVAC230- 3P0 -xxT	3.0	12.5	13.8	IP21/54	MR4	128x328x190	6
HVAC230- 4P0 -xxT	4.0	18	19.8	IP21/54	MR5	144x419x214	10
HVAC230- 5P5 -xxT	5.5	24	26.4	IP21/54	MR5	144x419x214	10
HVAC230- 7P5 -xxT	7.5	31	34.1	IP21/54	MR5	144x419x214	10
HVAC230- 11P -xxT	11.0	48	52.8	IP21/54	MR6	195x557x229	20
HVAC230- 15P -xxT	15.0	62	68.2	IP21/54	MR6	195x557x229	20
HVAC230- 18P -xxT	18.5	75	82.5	IP21/54	MR7	237x660x259	37.5
HVAC230- 22P -xxT	22.0	88	96.8	IP21/54	MR7	237x660x259	37.5
HVAC230- 30P -xxT	30.0	105	115.5	IP21/54	MR7	237x660x259	37.5
HVAC230- 37P -xxT	37.0	143	154.0	IP21/54	MR8	290x966x343	66
HVAC230- 45P -xxT	45.0	170	187.0	IP21/54	MR8	290x966x343	66
HVAC230- 55P -xxT	55.0	208	225.5	IP21/54	MR8	290x966x343	66

*) xx in inverter type can be 21 for IP21 units and 54 for IP54 units. The sizes of both models are exactly the same.

HONEYWELL EMC CLASSES AND MARKET REQUIREMENTS

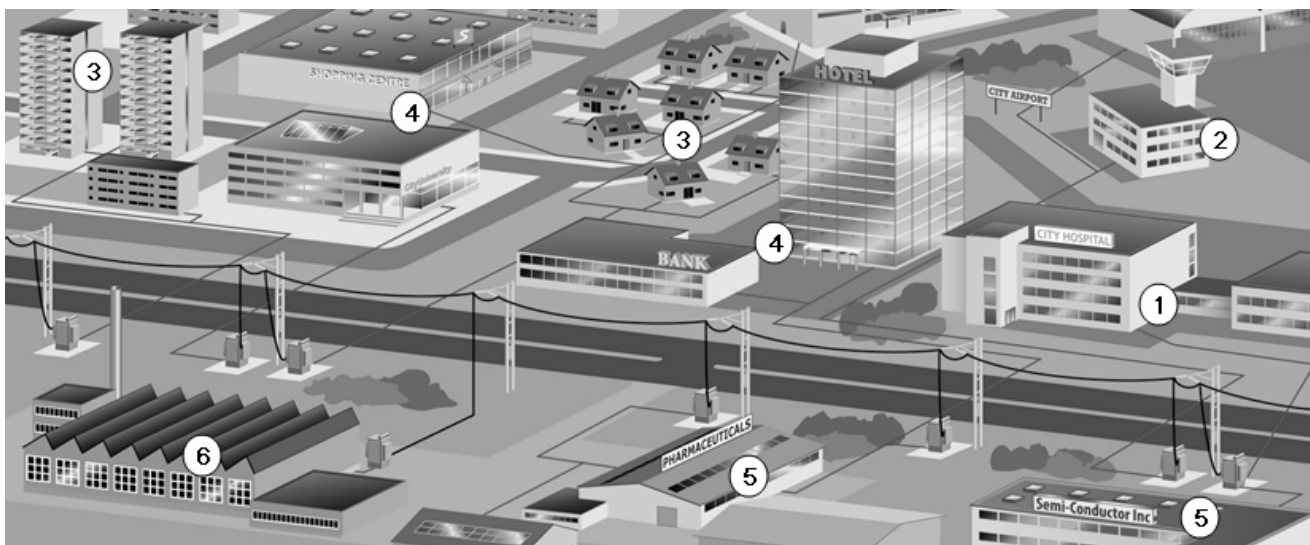

Fig. 2. EMC classes in practice

	1	2	3	4	5	6
EMC levels	Hospital	Airport	Residential Area	Commercial	Light Industry Area	Heavy Industry
C1	O	O	-	-	-	-
C2	R	R	R	R	O	O
C3	-	-	-	-	R	R
T						R (IT Network)

O = Optional, R= Required

C1 = EN61800-3 Category C1

C2 = EN61800-3 Category C2 (standard in SmartDrive HVAC)

C3 = EN61800-3 Category C3 (standard in Honeywell inverters >160 kW)

T = EN61800-3 IT network (e.g., ships) requirements fulfilled, units can be easily converted to T-class from standard EMC. Instructions for this can be found from manuals which can be downloaded from **Download Center** on the Honeywell inverter page <http://inverter.ecc.emea.honeywell.com>

MECHANICAL DIMENSIONS

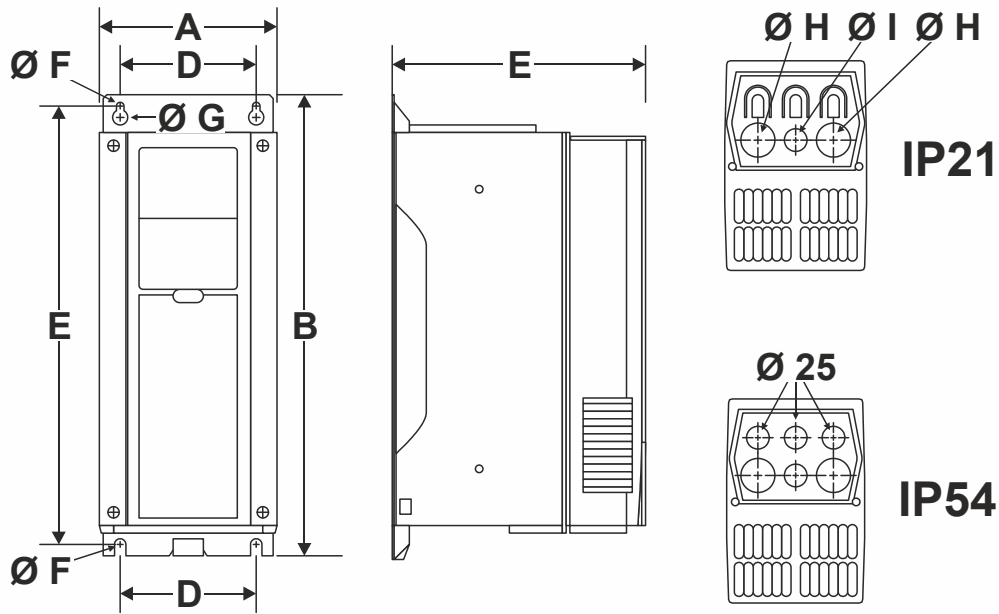

Fig. 3. Dimensions in millimeters

Mechanical size	Unit dimensions			Mounting hole distances		Hole sizes Ø			
	A	B	C	D	E	F	G	H	I
MR4	128	328	190	100	313	7	13	25	25
MR5	144	419	214	115 (*)	406	7	14	33	25
MR6	195	557	229	148	541	9	16	40	33
MR7	237	660	259	190	645	9	16	50	50
MR8	290	966	343	217	947	9	16	60	60

(* Two mounting hole options: 100 mm also available for Honeywell NX_ replacements

NOTE! All units have mounting holes equal to Honeywell NX_ products to ensure trouble-free replacement

COOLING

Forced-air flow cooling is used in all SmartDrive HVAC drives. Enough free space shall be left around the inverter to ensure sufficient air circulation and cooling. SmartDrive HVAC IP54 products can be mounted side by side. You will find the required dimensions for free space and cooling air in the tables below:

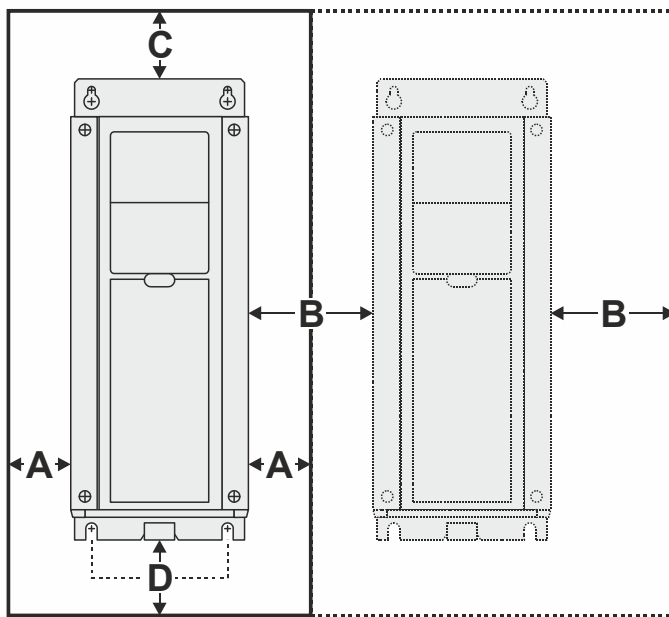

Fig. 4. Distances to ensure proper cooling

Mechanical size	Dimensions [mm]			
	A *)	B *)	C	D
MR4	20	20	100	50
MR5	20	20	120	60
MR6	20	20	160	80
MR7	20	20	250	100
MR8	20	20	300	150

- A** = clearance around the freq. converter (see also **B**)
- B** = distance from one frequency converter to another or distance to cabinet wall
- C** = free space above the frequency converter
- D** = free space underneath the frequency converter

*) No free space needed for A and B for IP54 models

Note! If several units are mounted above each other, the outlet air used for cooling by the lower unit must be directed away from the air intake of the upper unit by means of, e.g., a piece of metal plate fixed to cabinet wall between the drives. Cooling air required for each model can be found from the table below. For maximum heat losses in each product, check the SmartDrive HVAC installation manual (<http://inverter.ecc.emea.honeywell.com>)

Mechanical size	Cooling air requirements (m ³ / h)
MR4	45
MR5	75
MR6	190
MR7	185
MR8	335

CABLING AND FUSES

Use cables with a heat resistance of at least +70 °C. The cables and the fuses must be dimensioned according to the following tables. The fuses function also as cable overload protection. These instructions apply only to cases with one motor and one cable connection from the inverter to the motor. In any other case, ask the technical support for more information.

Connection	Cable type
Mains cable	Power cable intended for fixed installation and the specific mains voltage. Shielded cable not required. (MCMK or similar recommended).
Motor cable	Power cable equipped with compact low-impedance shield and intended for the specific mains voltage. (NKCABLES /MCCMK, SAB/ÖZCUY-J or similar recommended). 360° grounding of both motor and inverter connections required to meet the standards.
Control cable	Screened cable equipped with compact low-impedance shield (NKCABLES /Jamak, SAB/ÖZCuY-O or similar).

Cable and fuse sizes						
Size	Type (voltage-power)	I _N [A]	Fuse [A]	Mains cable Cu [mm ²]	Terminals cable size (min/max)	
					Main terminal [mm ²]	Earth terminal [mm ²]
MR4	230-P55 – 230-P75	3.7 – 4.8	6	3x1.5 + 1.5	1 – 6 (solid) 1 – 4 (stranded)	1 – 6
	230-1P1 – 230-1P5	5.6 – 8.0	10	3x1.5 + 1.5	1 – 6 (solid) 1 – 4 (stranded)	1 – 6
	230-2P2 – 230-3P0	9.6 – 12.5	16	3x2.5 + 2.5	1 – 6 (solid) 1 – 4 (stranded)	1 – 6
MR5	230-4P0	16.0 – 18.0	20	3x6 + 6	1 – 10 Cu	1 – 10
	230-5P5	23.0 – 24.0	25	3x6 + 6	1 – 10 Cu	1 – 10
	230-7P5	31.0	32	3x10 + 10	1 – 10 Cu	1 – 10
MR6	230-11P	38.0	40	3x10 + 10	2.5 – 50 Cu/Al	2.5 – 35
	230-15P	46.0 – 48.0	50	3x16 + 16 (Cu) 3x25 + 16 (Al) (*)	2.5 – 50 Cu/Al	2.5 – 35
	230-18P	61.0 – 62.0	63	3x25 + 16 (Cu) 3x35 + 16 (Al) (*)	2.5 – 50 Cu/Al	2.5 – 35
MR7	230-22P	72.0 – 75.0	80	3x35 + 16 (Cu) 3x50 + 16 (Al) (*)	6 – 70 Cu/Al	6 – 70
	230-30P	87.0 – 88.0	100	3x35 + 16 (Cu) 3x70 + 21 (Al) (*)	6 – 70 Cu/Al	6 – 70
	230-37P	105.0	125	3x50 + 25 (Cu) 3x70 + 21 (Al) (*)	6 – 70 Cu/Al	6 – 70
MR8	230-45P	140.0	160	3x70 + 35 (Cu) 3x95 + 29 (Al) (*)	Bolt size M8	Bolt size M8
	230-55P	170.0	200	3x95 + 50 (Cu) 3x150 + 41 (Al) (*)	Bolt size M8	Bolt size M8
	230-P55 – 230-P75	205.0	250	3x120 + 70 (Cu) 3x185 + 57 (Al) (*)	Bolt size M8	Bolt size M8

(* Note! In the case of aluminum (Al) cables, only the phase cables are of aluminum; the earthing cable size is for copper (Cu).

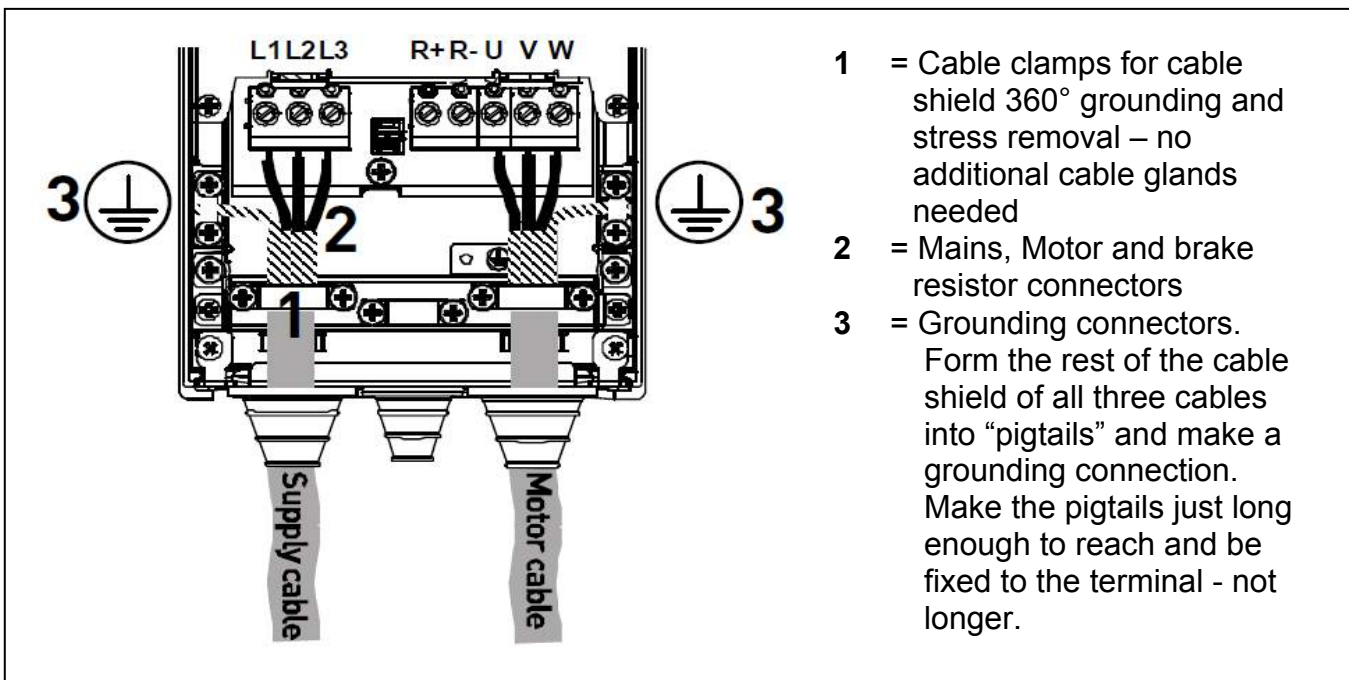

- 1 = Cable clamps for cable shield 360° grounding and stress removal – no additional cable glands needed
- 2 = Mains, Motor and brake resistor connectors
- 3 = Grounding connectors. Form the rest of the cable shield of all three cables into “pigtails” and make a grounding connection. Make the pigtails just long enough to reach and be fixed to the terminal - not longer.

Fig. 5. SmartDrive HVAC power connections

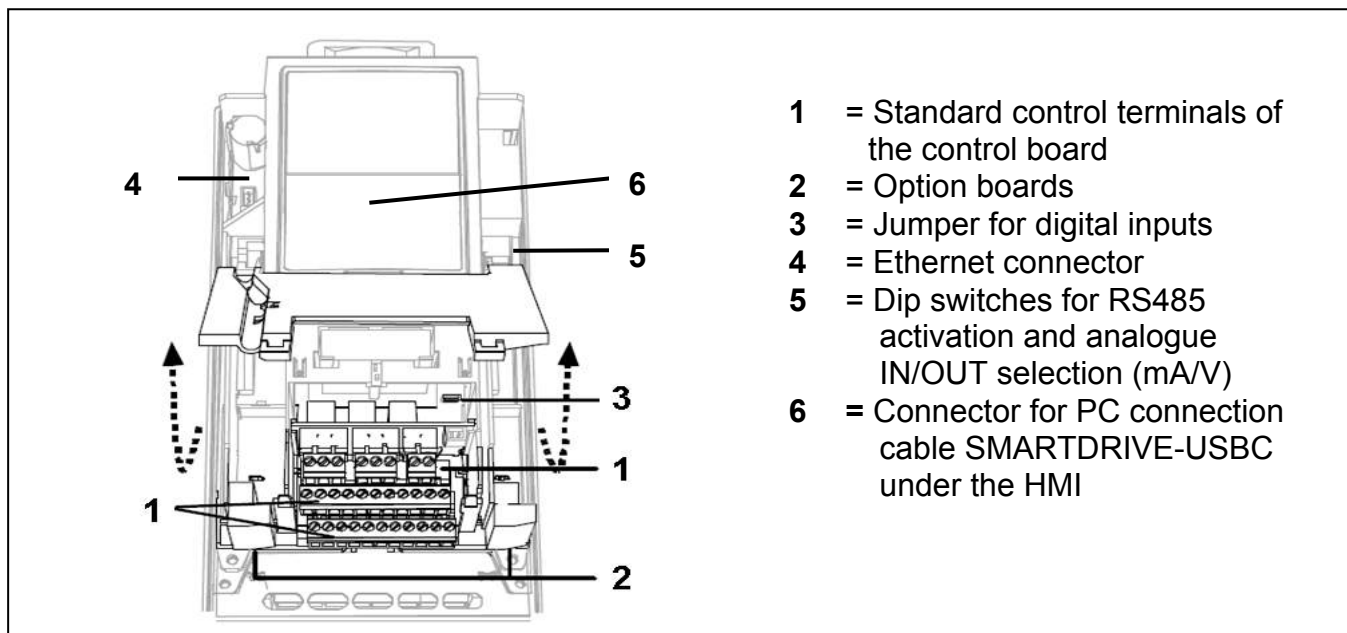

- 1 = Standard control terminals of the control board
- 2 = Option boards
- 3 = Jumper for digital inputs
- 4 = Ethernet connector
- 5 = Dip switches for RS485 activation and analogue IN/OUT selection (mA/V)
- 6 = Connector for PC connection cable SMARTDRIVE-USBC under the HMI

Fig. 6. SmartDrive HVAC control connections location

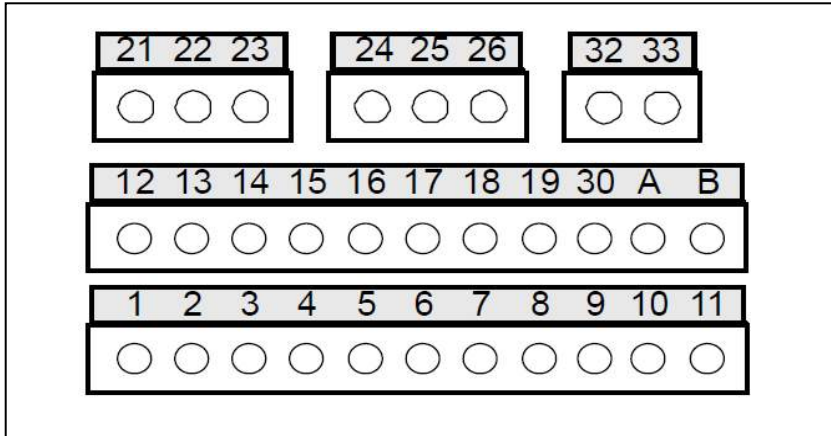

Terminal	Signal	Factory setting	
1	+10V _{RE}	+10Vdc Reference Voltage output	
2	AI1+	Analog Input 1 (mA or V)	Speed reference, 0-10V (P)
3	AI1-	Analog Input 1 common (mA)	
4	AI2+	Analog Input 2 (mA or V)	PID actual value 1, 4-20 mA (P)
5	Ai2-	Analog Input 2 common (mA)	
6	24V _{OUT}	24Vdc Auxiliary Voltage Output	
7	GND	I/O Signal Ground	
8	DI A.1	Digital Input A.1	Start forward (P)
9	DI A.2	Digital Input A.2	No function (P)
10	DI A.3	Digital Input A.3	External Fault, close (P)
11	CM	Common for DI A.1 - 6	
12	24V _{OUT}	24Vdc Auxiliary Voltage Output	
13	GND	I/O Signal Ground	
14	DI A.4	Digital Input A.4	Preset speed select B0 (P)
15	DI A.5	Digital Input A.5	Preset speed select B1 (P)
16	DI A.6	Digital Input A.6	Fault Reset (P)
17	CM	Common for DI A.1 - 6	
18	AO1+	Analog Output A.1	Output frequency, 0-20mA (P)
19	AO1- / GND	Analog Output A.1 common	
30	+ 24 V _{IN}	24 Vdc auxiliary input for backup power	
A	A	RS485 Signal A (negative)	Field bus communication
B	B	RS485 Signal B (positive)	Field bus communication
21	RO1/1		Active = RUN (P)
22	RO1/2		
23	RO1/3		
24	RO2/1		Active = FAULT (P)
25	RO2/2		
26	RO2/3		
32	TI+	Motor Protection Thermistor Input;	
33	TI-	R _{TRIP} = 4.7 kΩ (PTC)	

(P) = programmable function, see parameter lists in SmartDrive HVAC manuals (<http://inverter.ecc.emea.honeywell.com>)

Fig. 7. SmartDrive HVAC control connection terminals

FEATURES / FUNCTIONS

- Easy-to-set-up features**

Feature	Functions	Benefit
Start-up wizard	Similar Start-up wizard as in Honeywell NXL HVAC and SmartDrive Compact inverters for basic pump and fan applications. <ol style="list-style-type: none"> 1. Language selection 2. Real time clock setting 3. Select mode (Fan or Pump) 4. Tune the motor nominal speed 5. Tune the motor nominal current DONE	<ul style="list-style-type: none"> • Fully configured inverter for the application in question • Ready to accept 0-10V analog speed signal in just 30 seconds
Quick Setup Menu	Only the most commonly used parameters visible in this menu to provide easier navigation.	<ul style="list-style-type: none"> • Easy navigation through the most common parameters
Mini wizards	Also following mini wizards for quick and easy setup of more demanding applications. All accessible from the Quick setup menu: <ol style="list-style-type: none"> 1. PID wizard 2. Pump and Fan Cascade wizard 3. Resonance sweep wizard (for easy elimination of possible resonance points in the system) 	<ul style="list-style-type: none"> • Easy guided set-up for even more demanding applications
“Local – Remote” button	Dedicated push button on the HMI to enter the control place change selection and manual control view.	<ul style="list-style-type: none"> • Single button operation to change the control to manual (keypad) and back. Useful function when commissioning and testing applications
Honeywell Drive Care – PC tool	Easy-to-use PC-tool for commissioning the SmartDrive Inverters. Connection with SMARTDRIVE-USBC cable directly to the USB port of the PC. PC-tools available for download free of charge from http://inverter.ecc.emea.honeywell.com (download center)	<ul style="list-style-type: none"> • Parametering with PC • Saving settings to PC • Creating commissioning documentation • Comparing parameter settings • Monitoring view with graphics • Diagnostics
Parameter copy with HVAC-HMI-A	Parameter sets can be copied from one SmartDrive HVAC unit to another with the help of Advanced Commissioning HMI	<ul style="list-style-type: none"> • Fast and easy setup of several similar applications

- Compact and robust design with easy installation**

Feature	Functions	Benefit
Compact size	One of the most compact and light products in the market place. Available both IP21 and IP54 enclosures.	<ul style="list-style-type: none"> • Space savings • Easy handling and mounting
Integrated RFI-filters	The units comply with EN61800-3 category C2 as standard. This level is the required level for public electricity networks such as buildings.	<ul style="list-style-type: none"> • Easy selection and installation of products • Space savings • Cost savings
Integrated DC-choke	To minimize harmonics (THD) from the device, all products equipped with chokes as standard.	<ul style="list-style-type: none"> • Low THD • Fulfils EN61000-3-12
Varnished Printed Circuit Boards	All SmartDrive HVAC PCBs (also option boards) are varnished.	<ul style="list-style-type: none"> • Increased reliability
Integrated stress removal	Stress removal and 360° grounding of power cables inside the unit with clamps. No need for extra glands.	<ul style="list-style-type: none"> • Cost saving • Easy Installation

• **Uninterruptible operation and energy saving functions**

Feature	Functions	Benefit
Over-temperature ride-through	Automatically adjusts switching frequency and speed of the motor to adapt to unusual increase in ambient.	• Uninterruptible operation
Power ride-through	Automatically lowers motor speed to adapt to sudden voltage drop such as power loss.	• Uninterruptible operation
RTO – Ramp Time Optimizer	When problematic areas are identified in acceleration or deceleration, the drive automatically expands the times needed for this to avoid mechanical stress to the system.	• Decreased mechanical stress to the system
Motor switch function	Ensures trip-free operation when an output switch (e.g., safety switch) is operated between the motor and the VFD. Truly intelligent and highly reliable function to ensure better functionality than with any other VFD.	• Uninterruptible operation
Energy Saving function	Automatically minimizes energy consumption by optimizing the voltage/frequency curve.	• Up to 5% increase in energy savings.
Configurable auto reset function	Auto restart function can be configured to make VFD restart automatically once fault is addressed.	• Uninterruptible operation

• **VFD and motor control features**

Feature	Functions	Benefit
Single input control	Analog signal rising edge can be used to start the device without additional start signal to a digital input.	• Cost and time savings
Flying start	Ability to get an already spinning fan under speed control.	• Improved performance • Very important in clean room production
Automatic torque boost function	Boosts initial voltage to start high inertia fans.	• Avoids tripping and enables smooth starts even to high inertia loads
High Switching Frequency	Honeywell SmartDrive COMPACT is capable of providing the maximum power with high switching frequency.	• Low audible noise from the motor
Prohibit frequency	Overriding the critical frequencies to avoid resonance. Can be set with the help of resonance sweep wizard.	• Elimination of resonance
Maintenance counters/alarms	The drive can be programmed to notify on upcoming maintenance for the system or the drive itself.	• Reliability
Temperature-controlled fans	Fan stops operating when not needed.	• Less audible noise from the VFD itself • Energy savings

• **Advanced HVAC control features**

Feature	Functions	Benefit
Time-based control	With the help of the real time clock and calendar functionality the drive can be programmed to perform functions based on time.	• Cost savings • Flexibility
Inbuilt PID controller	<ul style="list-style-type: none"> • Normal and Inverse Regulation • Delta P regulation with 2 standard pressure transmitters • Feed forward control • Less wiring since sensor normally close to inverter 	• Cost saving • Faster response to process closed loop
Sleep Mode	Shutting down the motor, when no demand	• Energy savings
Pressure loss compensation	For compensating, e.g., incorrectly placed sensor in the system	• Time and cost saving
Pump Soft fill	Feature to prevent the overpressures when filling empty pipe work.	• Longer lifetime of the system
Fire override mode	Keeps fan/pump running in case of fire.	• Legal requirement
Pump and Fan Cascade control with full auto-change	Controls total pumping system with several parallel pumps by equally sharing the load. Also the master pump can be included in auto-change loop.	• Longer lifetime of the system • Cost savings

OPTIONAL ACCESSORIES AND SPARE PARTS

Option boards	Order type code
6 selectable digital IN/OUT	OPTB1
1 analog IN and 2 analog OUT, 0(4)-20 mA, galvanically isolated	OPTB4
3 relay (NO) OUT	OPTB5
1 relay (NO) OUT and 5 high voltage (41-240Vac) digital IN	OPTB9
1 analog OUT (0/2-10V or 0/4-20mA), 2 digital OUT: 1 open collector and 1 relay (NO)	OPTBF
Field bus: LONWORKS	OPTC4

Keypads and Keypad mounting kits	Order type code
Standard text HMI for SmartDrive HVAC	HVAC-HMI-S
Advanced Commissioning HMI for SmartDrive HVAC with parameter copy function	HVAC-HMI-A
Door mounting kit for SmartDrive HVAC HMI with 3.0 m connection cable	HVAC-DOOR-KIT
Hand Held kit for SmartDrive HVAC HMI with 3.0 m connection cable	HVAC-HAND-KIT

PC connection options	Order type code
SmartDrive 3.0m USB PC connection cable	SMARTDRIVE-USBC

Spare parts	Order type code
Main cooling fan spare part for SmartDrive HVAC size MR4 (HVAC230-P55 to 3P0)	HVAC-FAN-4
Main cooling fan spare part for SmartDrive HVAC size MR5 (HVAC230-4P0 to 7P5)	HVAC-FAN-5
Main cooling fan spare part for SmartDrive HVAC size MR6 (HVAC230-11P to 15P)	HVAC-FAN-6
Main cooling fan spare part for SmartDrive HVAC size MR7 (HVAC230-18P to 30P)	HVAC-FAN-7
SmartDrive HVAC control unit spare part with preloaded firmware	HVAC-CONTROL
SmartDrive HVAC control terminal spare part set, includes all control cable terminals	HVAC-TERM-KIT

Honeywell

Manufactured for and on behalf of the Environmental and Combustion Controls Division of Honeywell Technologies Sàrl, Rolle, Z.A. La Pièce 16, Switzerland by its Authorized Representative:

Automation and Control Solutions

Honeywell GmbH
 Böblinger Strasse 17
 71101 Schönaich, Germany
 Phone +49 (0) 7031 637 01
 Fax +49 (0) 7031 637 740
<http://ecc.emea.honeywell.com>

EN0B-0673GE51 R0414

Subject to change without notice