

M7061

ROTARY VALVE ACTUATORS

PRODUCT DATA

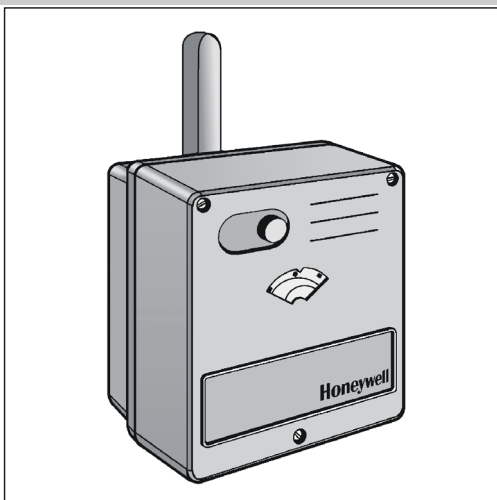

FEATURES

- Protected against overload and blocking
- Maintenance-free electrical actuator for rotary valves
- Clear position indicator
- Direct mounting on rotary valves
- Manual operation
- High torque
- Large wiring cabinet
- Long lifetime

TECHNICAL DATA

Power supply	24 Vdc ($\pm 10\%$) 24 Vac (+15% / -20%, 50/60 Hz)
Power consumption	100 mA
Control signal	0...10 V / 2...10 V
Angle of rotation	90°
Run time	model-dependent; see table
Nominal torque	model-dependent; see table
Protection standard	IP 54 per EN 60529
Insulation class	I per EN 60730
Ambient operating temperature	0...45 °C
Water temperatures in valve	2...110 °C
Relative humidity	non-condensing
Weight	1.5 kg

APPLICATION

The Honeywell M7061 actuator is designed to provide modulating control in heating and air conditioning systems. High control performance and a robust design are standard for this actuator. In combination with Honeywell valves, it is possible to control very exact heating and cooling water temperatures. The mechanical interface between actuator and valve is designed for reliable operation. Actuators with torques from 10 Nm up to 20 Nm are available for a wide range of rotary mixing valves (DN 15 up to DN 80) and 2-port valves (DN15 up to DN65).

Model-Specific Technical Data

torque	run time	valve dimension	OS number
10 Nm	~ 1.5 min	DN15 to DN40	M7061E1012
20 Nm	~ 3.0 min	DN15 to DN80	M7061E1020

Suitable Valves

2-port: V5004TY, V5421B, VBG2

3-port: VBG3, DRxxxGMLA, DRxxxGFLA

OPERATION

The actuator is powered by a DC-motor. The spindle of the actuator rotates 90°. The position is controlled by internal electronics.

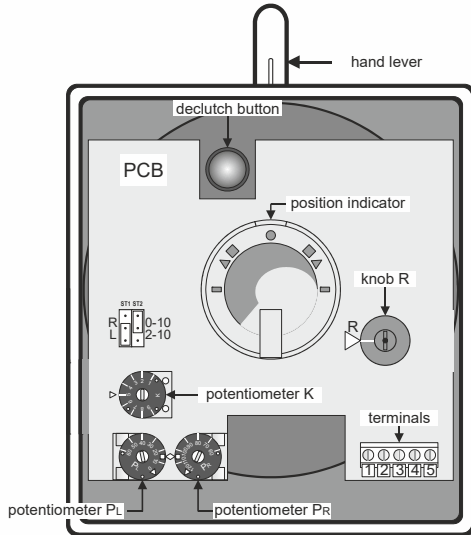

Fig. 1. Main features

The angle of rotation is electronically limited and can be adjusted (see section "Angle of Rotation"). The spindle can also be rotated manually by using the declutch button (see Fig. 1) to disengage the gear and then turning the hand lever. As soon the actuator is powered, the valve is driven by the actuator again.

An electrical overload circuit protects the actuator. If the rated torque is exceeded, the actuator is switched OFF automatically.

The actuator is maintenance-free.

Commissioning and Service

Direction of Motor Rotation

The direction of rotation can be defined using jumper **ST1** (see Fig. 1).

- ST1 in "L" (left) position (factory setting): clockwise rotation 0 → 100% (i.e. when Y = 0 Vdc, the hand lever is at the left end)
- ST1 in "R" (right) position: counterclockwise rotation 100% ← 0 (i.e. when Y = 0 Vdc, the hand lever is at the right end).

Input Signal Y

The input signal Y can be set using jumper **ST2** (see Fig. 1):

- ST2 in the upper position (factory setting): Y = 0...10 Vdc
- ST2 in lower position: Y = 2...10 Vdc

Adjusting Spindle to Feedback Potentiometer

The position of the spindle can be adjusted to match the signal from the feedback potentiometer using **knob R** (see Fig. 1). With the motor in the center position (the mark on the hand lever must line up with the mark on the motor housing),

the graduation on knob R must point to the triangle on the PCB (factory setting). Adjustment is required only if the printed circuit board is changed for servicing.

Actuator Characteristic

The actuator characteristic, i.e. the relation between motor rotation and the input signal Y, can be altered to suit the given valve using **potentiometer K** (see Fig. 1). The curve of the characteristic between its start and end points can be adjusted infinitely between convex, linear and concave (see Fig. 2). Potentiometer K is marked with the numerals 1 through 9. The linear characteristic K = 5 is the factory setting.

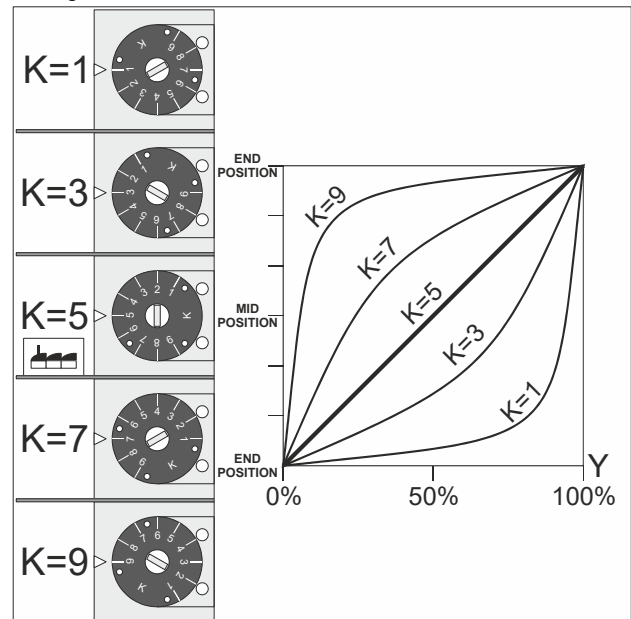

Fig. 2. Characteristic curve

Examples

When mounting the proportional actuator onto a valve with a linear characteristic, an equal percentage characteristic on the controlled unit can be achieved by setting a concave curve ($K \approx 3$).

An actuator used together with an oversized mixing valve is a further application requiring a concave curve ($K \approx 3$).

If Y = 50% and $K \neq 5$, then the actuator will not stop at the mid position.

If, however, Y = 50% and $K = 5$, then the actuator will stop at the mid position.

Angle of Rotation

The angle of rotation is adjustable via the **potentiometers PL and PR** (see Fig. 1). Start and end points can be adjusted independently.

The nominal angle is 90° ($105^\circ - 15^\circ = 90^\circ$); the potentiometers are factory set as follows: PL = 15 and PR = 105.

These settings are marked by a square ■.

The desired angle can be adjusted by changing the start and end points; within the total range, all angles are possible.

The start point can be adjusted between 0 and 60° using potentiometer P_L, while the end point is adjustable between 60° and 120° using potentiometer P_R.

Fig. 3 shows an example setting of the angle rotation in which the start point has been set to 15° and the end point to 105°, and Fig. 4 shows the corresponding relation between the input signal and the angle of rotation.

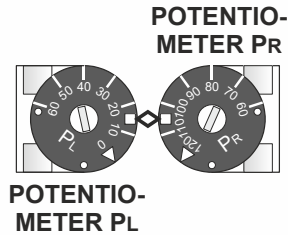

Fig. 3. Example setting of angle of rotation (P_L and P_R)

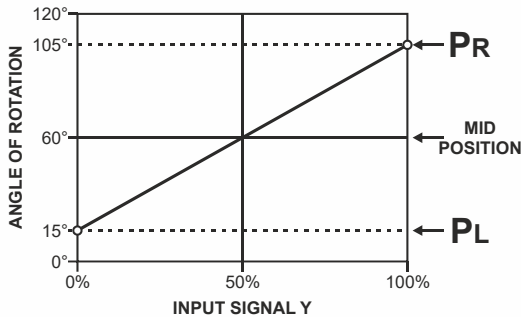

Fig. 4. Input signal Y and angle of rotation

NOTE: Setting angles of rotation which cause the actuator to drive against the mechanical end-stop will decrease the actuator's effective lifetime.

Limitation of Angle of Rotation

To limit the flow through a 2-port valve, the open portion can be limited using the potentiometer P_L. The settings for V5004TY and V5421B are listed in Table 1.

Table 1. Setting the potentiometer P_L

	100%	90%	80%	70%	60%	50%	40%	30%
P _L	15°	24°	33°	42°	51°	60°	--	--
Cm	-6.0	-4.4	-3.1	-1.9	-1.0	0.0	+1.0	+1.9
V5421B	90°	80°	70°	60°	50°	45°	30°	20°
P _L	15°	25°	35°	45°	55°	60°	--	--
Cm	-6.0	-4.2	-2.8	-1.6	-0.5	0.0	+1.6	-2.8

The settings can be verified by measuring the angle using a protractor or by measuring the distance from the central marking using a ruler (see Fig. 5).

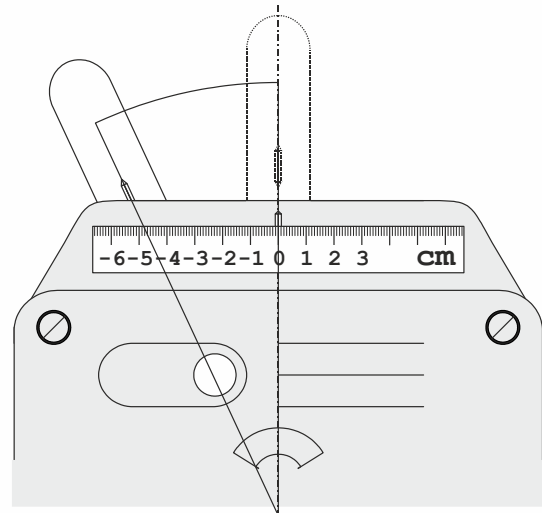

Fig. 5. Verifying setting at lever

Accessory

VMU1

The VMU1 is an optional accessory which provides a feedback value (output signal) indicating the actuator's current position.

After removing the M7061's cover, the VMU1 is pushed onto the M7061's printed circuit board in the desired position until it locks itself.

The switch located at the upper edge of the housing of the VMU1 adjusts the direction of rotation of the M7061. It must be adjusted to correspond with the position of jumper ST1.

The angle of rotation of the M7061 is then set using potentiometer Y on the VMU1 housing. Potentiometer Y must be adjusted to the same symbol (square or triangle) as potentiometer P_L or P_R.

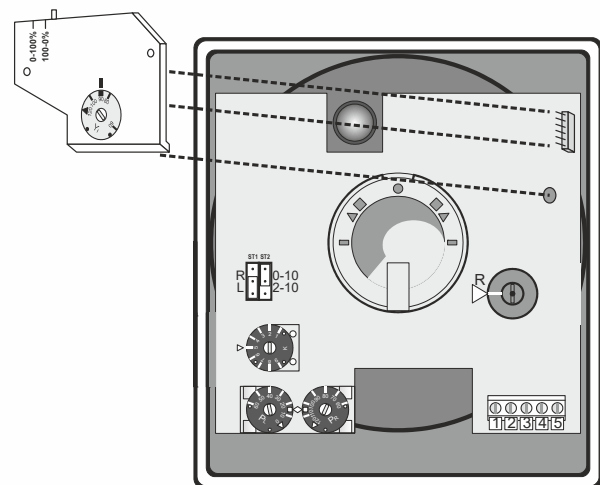

Fig. 6. Mounting VMU1

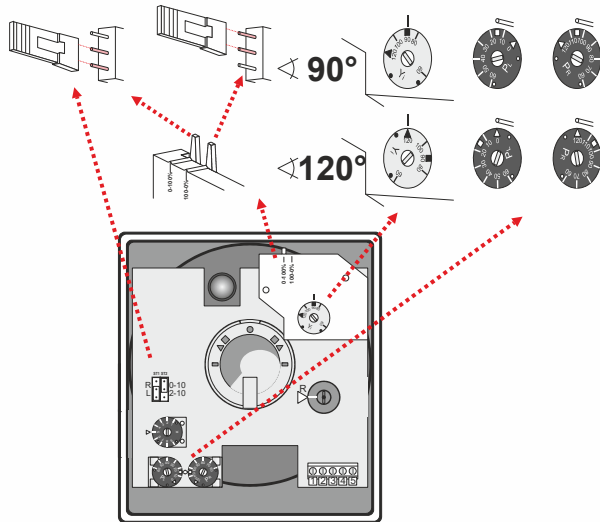

Fig. 7. Adjusting settings

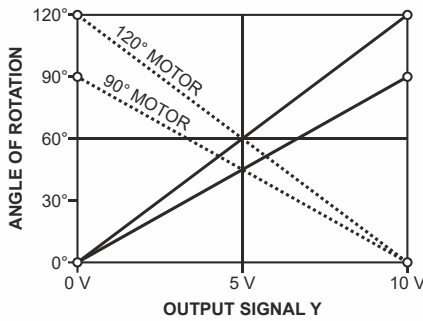

Fig. 8. Output signal Y and angle of rotation with VMU1

Mounting on the Valve

Before mounting the actuator, position the rotary valve as appropriate.

Table 2. Typical assembly positions

	Stroke	Operator
Mixing valves	50%	Center
Ball valves	0%	Right
Butterfly valves	0%	Right
V5004 valves	100%	left

For more information, see also M7061 - Installation Instructions (MU1B-0243GE51).

Electrical Connection

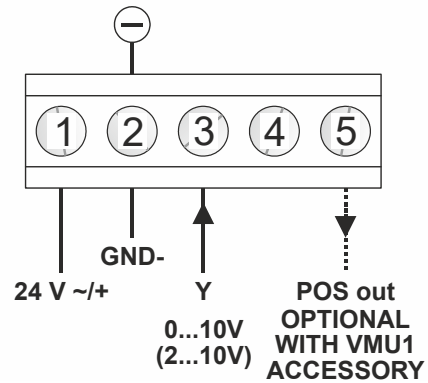

Fig. 9. Wiring

To override the input signal Y, i.e. in order to control the position from an external source, connect to motor terminals as follows:

- for a signal variable of 100%, connect terminal 3 to terminal 4
- for a signal variable of 0%, connect terminal 3 to terminal 2 (system ground or ground wire).

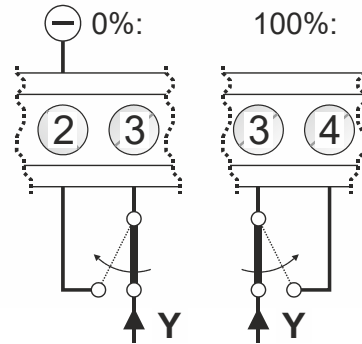

Fig. 10. Overriding the input signal Y

DIMENSIONS M7061

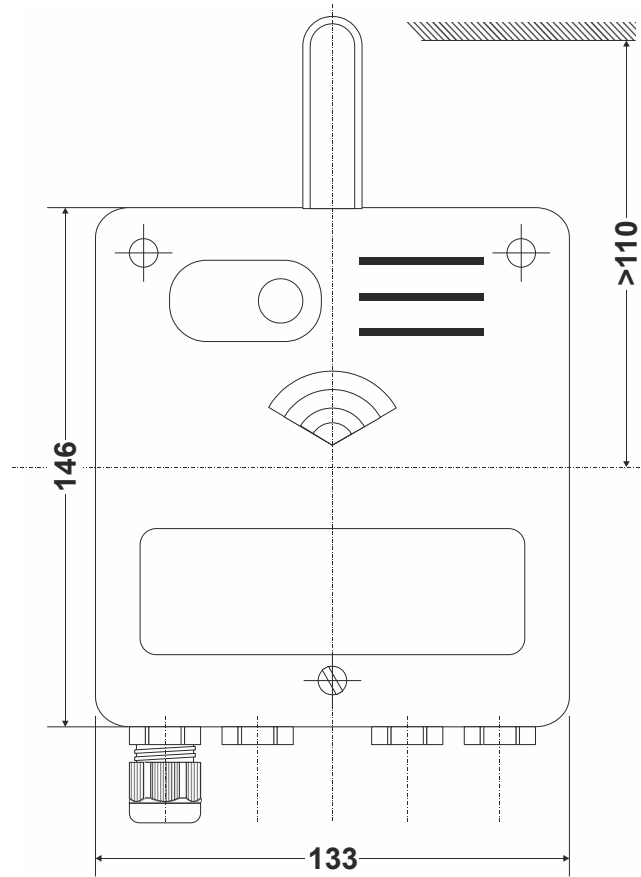

Fig. 11. M7061, dimensions (in mm)

Home and Building Technologies

Honeywell GmbH
Böblinger Strasse 17
71101 Schönaich, Germany
Phone +49 (0) 7031 637 01
Fax +49 (0) 7031 637 740
<http://ecc.emea.honeywell.com>