

## Electrical Energy Meter with integrated S0-interface EEM400-D-P

Electrical energy meter with LCD display and integrated S0 interface. The S0 interface (pronounced S-O-interface) is a hardware interface for the transmission of measured values in building automation.

### Main features:

- 3-phase energy meter, 3 × 230 / 400 VAC 50 Hz
- Direct measurement up to 65 A
- Display of active power, voltage and current for every phase
- Display of active power for all phases
- S0 output
- 7-digits display for 1 or 2 tariffs
- Lead seal possible with cap as accessory
- Accuracy class B according to EN50470-3, accuracy class 1 according to IEC62053-21

### Order Number

Standard Version:	EEM400-D-P
MID Version:	EEM400-D-P-MID
Sealing caps:	EEM400-SEALCAP (Bulk with 20 units)



### Technical data

Precision class	B according to EN50470-3, 1 according to IEC62053-21
Operating voltage	3 × 230 / 400VAC, 50 Hz Tolerance -20% / +15%
Reference/ measurement current	$I_{ref} = 10 \text{ A}$ , $I_{max} = 65 \text{ A}$
Starting/ minimum current	$I_{st} = 40 \text{ mA}$ , $I_{min} = 0.5 \text{ A}$
Power consumption	Active 0.4 W per phase
Counting range	00'000.00...99'999.99 100'000.0...999'999.9
Display	LCD backlit, digits 6 mm high
Display without mains power	Capacitor based LCD, max. 2 times over 10 days
S0 output (interface)	Optocoupler max. 30V / 20 mA and at least 5V, impedance 100Ω, pulse width 30 ms
Transmission distance, S0 output	Max. 1000 m (at 30 V / 20 mA)
Pulses per kWh	LED: 100 pulses/kWh S0 output: 1000 pulses/kWh

### Mounting

Mounting	On 35 mm rail, according to EN60715TH35
Terminal connections main circuit	Conductor cross-section 1.5...16 mm <sup>2</sup> , screwdriver Pozidrive no. 1, slot no.2, torque 1.5...2 Nm
Terminal connections control circuit	Conductor cross-section max. 2.5 mm <sup>2</sup> , screwdriver Pozidrive no.0, slot no.2, torque 0.8 Nm
Insulation characteristics	4 kV / 50 Hz test according to VDE0435 6 kV 1.2 / 50 μs surge voltage according to IEC255-4 Device protection class II
Ambient temperature	-25°...+55 °C
Storage temperature	-30°...+85 °C
Relative humidity	95% at 25°...+40 °C, without condensation
EMC/interference immunity	Surge voltage according to IEC61000-4-5 at main circuit, 4 kV Burst voltage according to IEC61000-4-4, 4 kV ESD according to IEC61000-4-2, contact 8 kV, air 15 kV

## Error display

Example: Connection error at L3

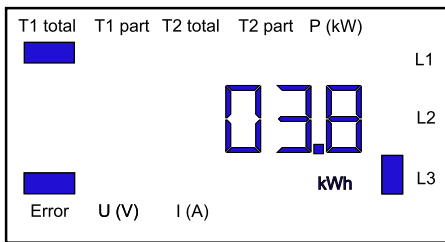

Example: Connection error at L1 and L3

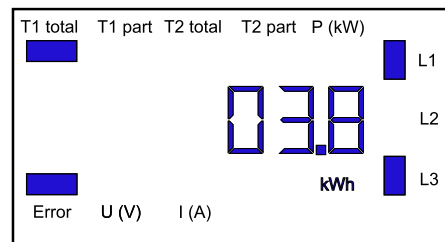

## Dimension drawings

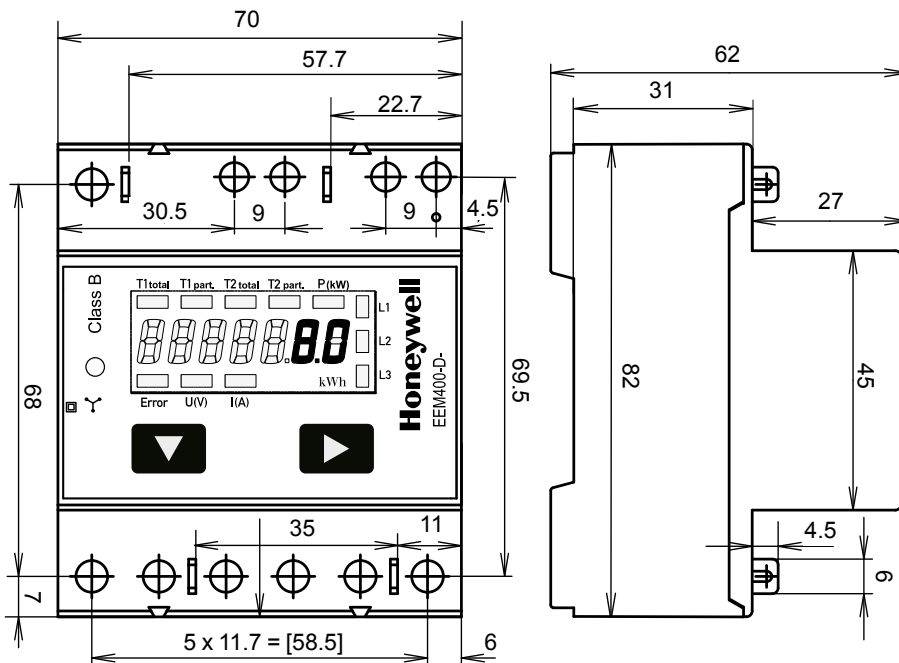

## Display elements, direct measurement

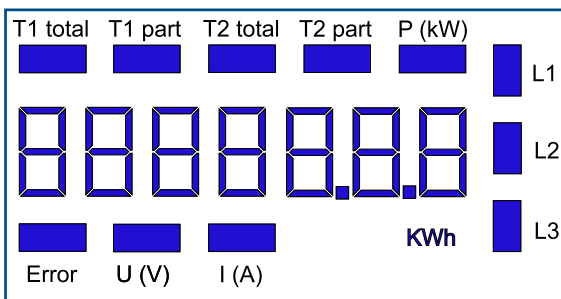

- T1 total (kWh) Indicates the total consumption for tariff 1
- T1 part (kWh) Indicates the partial consumption for tariff 1. This value can be reset
- T2 total (kWh) Indicates the total consumption for tariff 2
- T2 part (kWh) Indicates the partial consumption for tariff 2. This value can be reset
- P (kW) Indicates the instantaneous output per phase or for all phases
- U (V) Indicates the voltage per phase
- I (A) Indicates the current per phase
- kWh Indicates the unit kWh for display of consumption
- L1 / L2 / L3 Whenever the display shows P, U, I or Error. The corresponding phase will be indicated
- Error When phase is absent or current direction is wrong. The corresponding phase will also be indicated

## Menu to display the values on the LCD

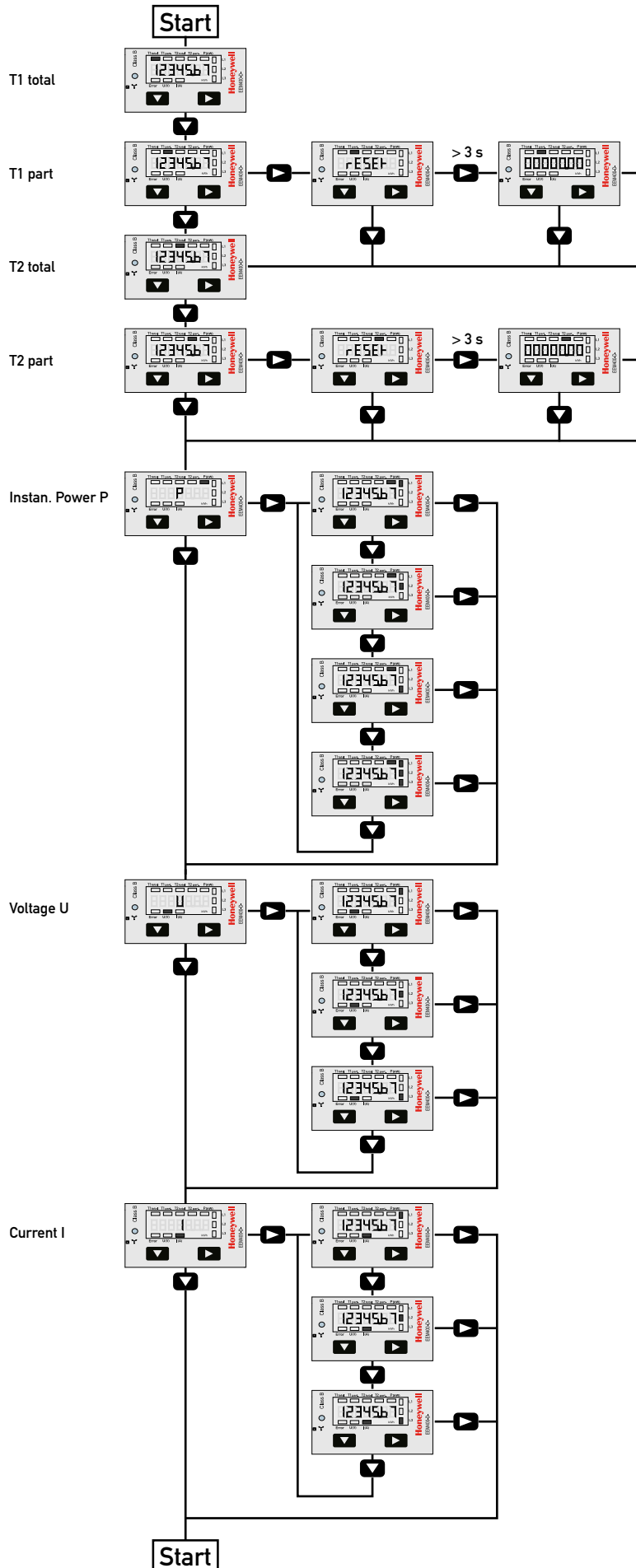

## Wiring diagram

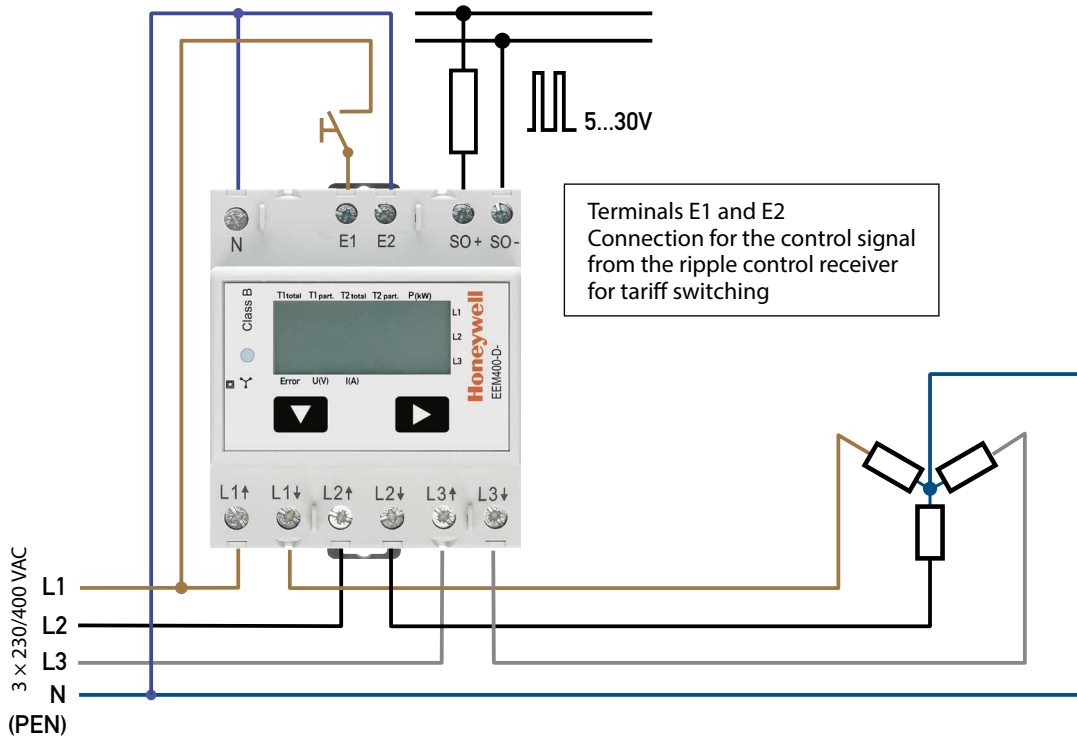

# Honeywell

Manufactured for and on behalf of the Environmental and Combustion Controls Division of Honeywell Technologies Sàrl, Rolle, Z.A. La Pièce 16, Switzerland by its Authorized Representative:

### Saia-Burgess Controls AG

Bahnhofstrasse 18  
3280 Murten / Switzerland

Phone +41 26 580 30 00  
Fax +41 26 580 34 99

Subject to change without notice. Printed in Switzerland  
PP26-591 EN02 07.2015