

Excel 10 W7751B,D,F VAV Controllers



INSTALLATION INSTRUCTIONS

BEFORE INSTALLATION

The Excel 10 VAV Controller is a Free Topology Transceiver (FTT) LonMark® compliant device that is available in three versions: See Fig. 1.

1. W7751B—OEM Snaptrack-Mount, reference part number 207912. Use a 3-1/4 inch by 9 inch (82 mm by 228 mm) section for each installation.
2. W7751D—Internally Wired Subbase mounts on a standard four by four, a standard five by five conduit box or on DIN Rail 1-3/8 by 9/32 (35 mm by 7.5 mm) EN 50 022.
3. W7751F—Externally Wired Subbase, can be mounted in a ring cabinet or on DIN Rail 1-3/8 by 9/32 (35 mm by 7.5 mm) EN 50 022.

The models all contain a Microbridge air flow sensor and communicate via the 78 Kilobaud Echelon® LonWorks® E-Bus Network. They differ only in mounting and terminations.

Any hardware that will be driven by the Triac outputs must have a minimum current draw, when energized, of 25 mA at 20 Vac, a maximum of 500 mA at 30 Vac for the W7751B and 1 A at 30 Vac for the W7751D,F.

INSTALLATION

Mount the VAV controllers in locations that allow clearance for wiring, servicing and module removal. (See Fig. 3 and 4 for mounting options used with the W7751D,F Subbase and Fig. 5 for mounting dimensions.)

W7751B

The W7751B OEM model is implemented on a snaptrack compatible printed wiring board (PWB). Terminal blocks are used to make connections to the digital input terminals (13 through 17) the wall module terminals (19 through 25), and the communications terminals 29 and 30. Connection for to access the E-Bus is provided by plugging the connector into the communications jack. Digital outputs, earth ground and 24 Vac power connections are made with quarter inch (6.35 mm) quick connects.

Mount the VAV controller onto the snaptrack. Attach all wiring to the appropriate quarter inch (6.35 mm) quick connects and terminal blocks. See Wiring section.

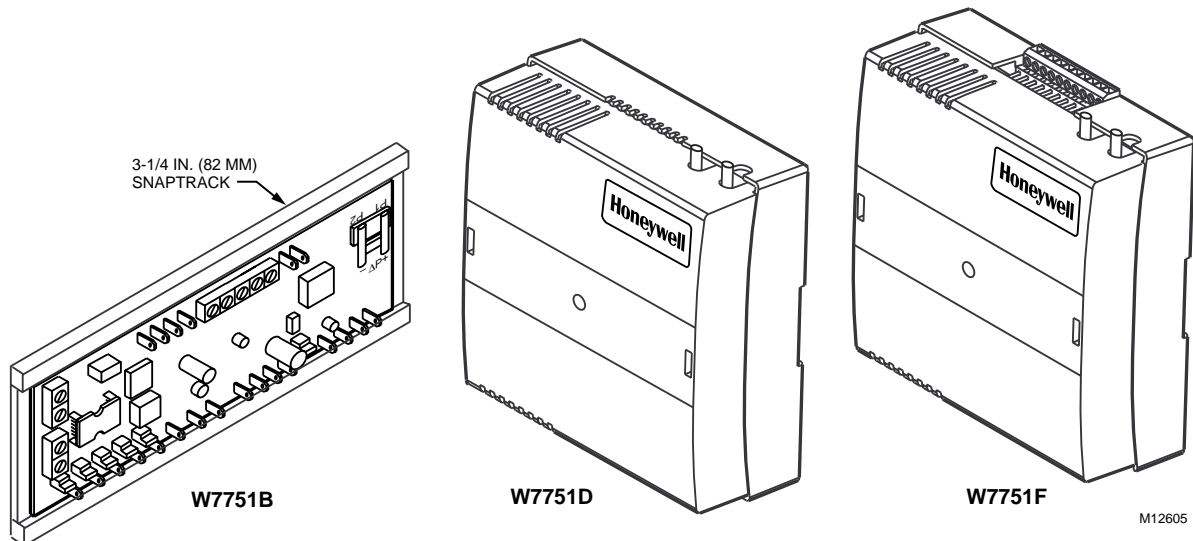

W7751D

The W7751D uses a two-piece construction controller module and an internally wired subbase. Remove the controller module from the subbase (see Fig. 2). Field wiring 14 to 22 AWG (2.0 to 0.34 mm²) comes through a conduit into the four by four or five by five conduit box and is connected to the terminal blocks on the subbase. When wiring is complete, the controller module activates by plugging into the subbase.

The internally wired subbase either mounts on a standard 4 inch by 4 inch electrical junction box or a standard 5 inch by 5 inch electrical junction box using No. 6 (3.5 mm) screws. See Fig. 3. Attach all wiring to the appropriate terminal blocks on the subbase. See Wiring section. After checking out all wiring, plug the controller module into the subbase. Wiring checkout and troubleshooting can also be performed with the controller module installed, by placing a probe through the slots in the subbase.

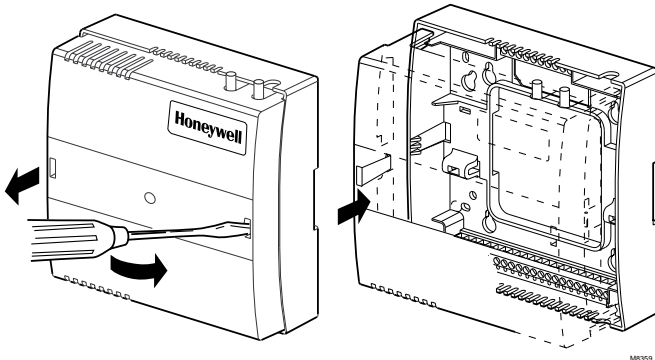

Fig. 2. W7751D,F controller module removal/replacement (W7751D shown).

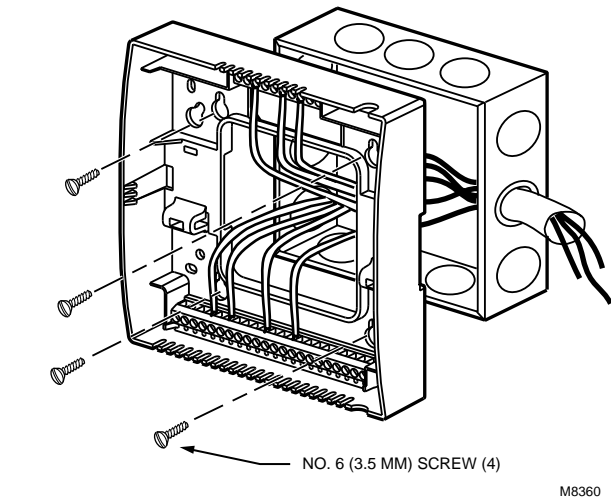

Fig. 3. W7751D Subbase four by four or five by five conduit box mounting options (proper orientation is vertical with terminals at top and bottom as shown).

W7751F

The W7751F uses a two-piece construction controller module and an externally wired subbase. Remove the controller module from the subbase (see Fig. 2). This subbase either mounts into a panel with screws or snaps onto standard EN 50 022 DIN rail 35 mm by 7.5 mm (1-3/8 in. by 5/16 in.). See Fig. 4. DIN rail is available through local suppliers. Mount the subbase to the appropriate surface. Type of screws (sheet metal, self-tapping or thread forming) and length is determined by the type of mounting material at the job site. Field wiring 14 to 22 AWG (2.0 to 0.34 mm²) is connected to the terminal blocks on the top and bottom external edges of the subbase. When wiring is complete, the controller module activates by plugging into the subbase.

Attach all wiring to the appropriate terminal blocks on the externally wired subbase. See Wiring section. After checking out all wiring, plug the controller module into the subbase.

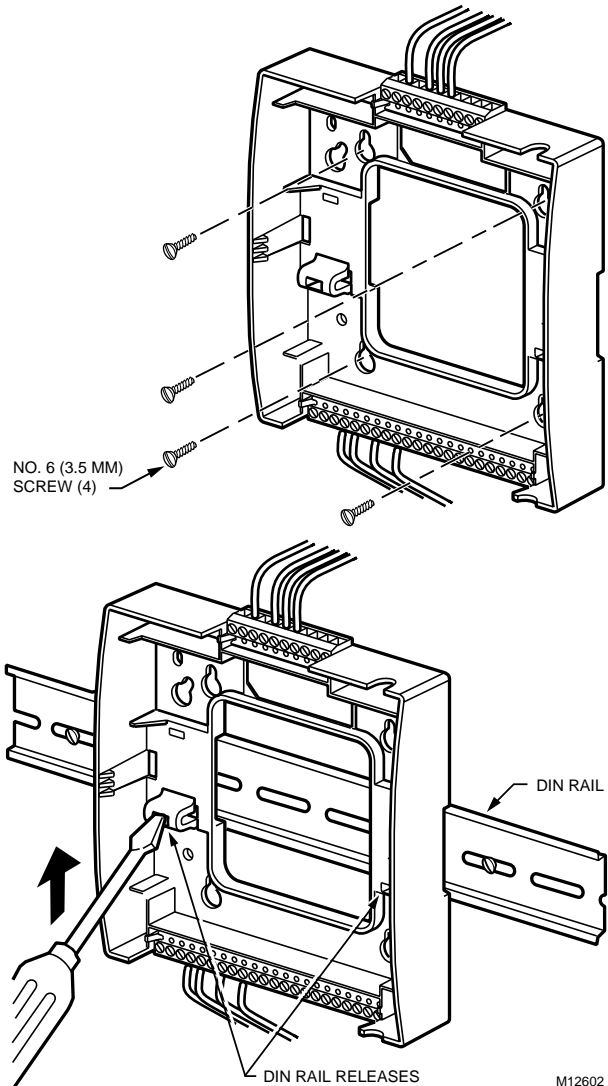

Fig. 4. W7751F Subbase wall and DIN rail mounting options (proper orientation is vertical with terminals at top and bottom as shown).

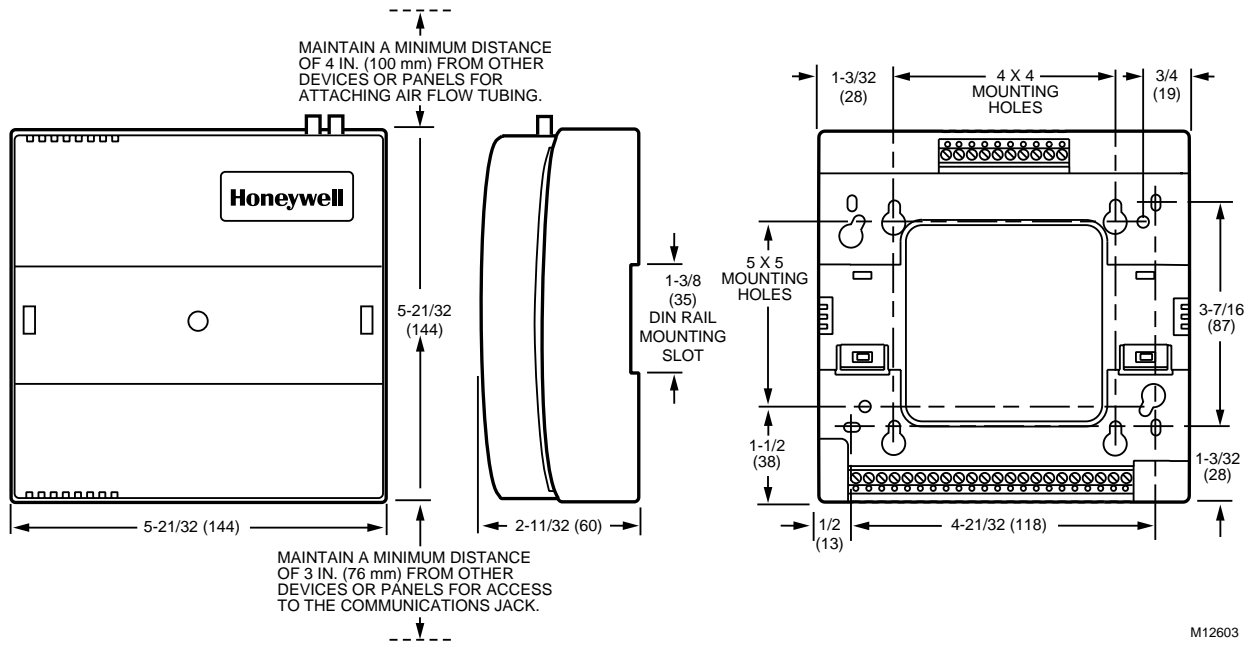

Fig. 5. W7751D,F Subbase mounting dimensions (W7751D shown).

M12603

Piping

Air flow Pickup

Connect the air flow pickup to the two connectors on the VAV controller. See Fig. 6.

NOTES:

- Use 1/4 inch (6 mm) outside diameter with 0.040 in. (1 mm) wall thickness plenum rated 1219 FR (94V-2) tubing.
- Always use a fresh cut on the end of the tubing that connects to the air flow pickups and the connectors on the VAV controllers.

Connect the high pressure or upstream tube to the plastic restrictor labeled (+) or P1 and the low pressure or downstream tube to the restrictor labeled (-) or P2. See labeling in Fig. 6.

NOTE: If controllers are mounted in unusually dusty or dirty environments, a 5-micron disposable air filter is recommended for the high pressure line (marked as +) connected to the air flow pickup. This applies to all controller models.

When twin tubing is used from the pickup, split the pickup tubing a short length to accommodate the connections.

NOTES:

- The tubing from the air flow pickup to the VAV controller should not exceed three feet (0.914m). Any length greater than this will degrade the flow sensing accuracy.
- Use caution when removing tubing from a VAV connector. Always pull straight away from the connector; never remove by pulling at an angle.

Wiring

All wiring must comply with applicable electrical codes and ordinances or as specified on installation wiring diagrams.

NOTES:

- For multiple controllers operating from a single transformer, the same side of the transformer secondary must be connected to the same input terminal in each controller and the ground terminals (28 on the W7751B, and 32 on the W7751D,F) must be connected to a verified earth ground for each controller in the group. See Fig. 7. (Controller configurations will not necessarily be limited to three devices, but the total power draw including accessories can not exceed 100 VA when powered by the same transformer (U.S. only). See System Engineering form, 74-2949, for power wiring recommendations.)
- The following pairs of terminals are electrically equivalent for 24 Vac power wiring:
W7751D,F terminals 1 and 3, 2 and 4.
- All loads on an Excel 10 controller must be powered by the same transformer that powers the Excel 10 controller.
- Keep the earth ground connection (terminal 28 on the W7751B, and terminal 32 on the W7751D,F) wire run as short as possible. Refer to Fig. 11 and 17.
- Do *not* connect the Analog ground nor Digital ground terminals (13, 16, 22 and 24 on the W7751B and 13, 18, 26, 28 and 31 on the W7751D,F) to earth ground. Refer to Fig. 11 and 17.

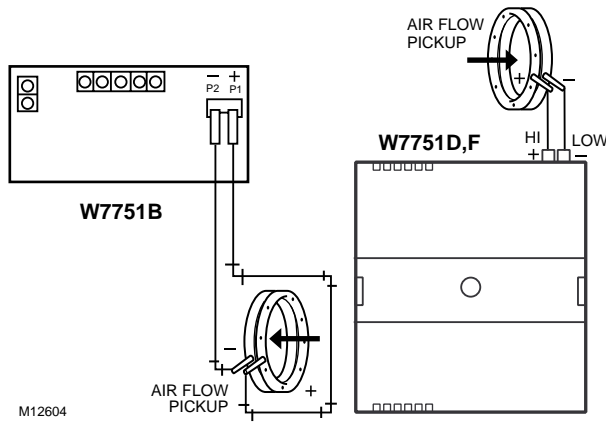

Fig. 6. VAV air flow pickup connections.

Power

The 24 Vac power from an energy limited Class II Power Source must be provided to each VAV controller. To conform to Class II restrictions, transformers must not be larger than 100 VA (U.S. only). A transformer that meets CE mark requirements and that meets the Low Voltage Directive (LVD) requirements must be used in Europe for all installations of this product.

IMPORTANT

Power must be off prior to connecting to or removing connections from terminals 9 and 10 on the W7751B and terminals 1 and 2 or 3 and 4 on the W7751D,F.

Use the heaviest gauge wire available, up to 14 AWG (2.0 mm²) with a minimum of 18 AWG (1.0 mm²) for all power and earth ground wiring. For nonplenum, open areas, run cables exposed (or in conduit if required).

See the following **IMPORTANT** on Heating and Cooling Equipment (UL 1995, U.S. only).

IMPORTANT

If the W7750 Controller is used on Heating and Cooling Equipment (UL 1995, U.S. only) and the transformer primary power is more than 150 volts, connect the transformer secondary to earth ground, see Fig. 7.

NOTES:

- Unswitched 24 Vac power wiring can be run in the same conduit as the E-Bus cable.
- Maintain a three-inch (76 mm) separation between Triac outputs and E-Bus wiring throughout installation.

Communications

Refer to E-Bus Wiring Guidelines form, 74-2865, for a complete description of E-Bus network topology rules. Approved cable types for E-Bus communications wiring are Level IV 22 AWG (0.34 mm²) plenum or non-plenum rated unshielded, twisted pair, solid conductor wire. For nonplenum areas, U.S. part AK3781 (one pair) or U.S. part AK3782 (two pair) can be used. In plenum areas, U.S. part

AK3791 (one pair) or U.S. part AK3792 (two pair) can be used. Communications wiring can be run in a conduit, if needed, with non-switched 24 Vac or sensor wiring. If a longer E-Bus network is required, a Q7740A 2-way or Q7740B 4-way repeater can be added to extend the length of the E-Bus. A Q7751A Router can be added to partition the system into two segments and effectively double the length of the E-Bus. Only one router is allowed with each Excel 10 Zone Manager, and each network segment can have a maximum of one repeater.

Pull the cable to each controller on the E-Bus and connect to communication terminals 29 and 30 (W7751B), 19 and 20 (W7751D,F).

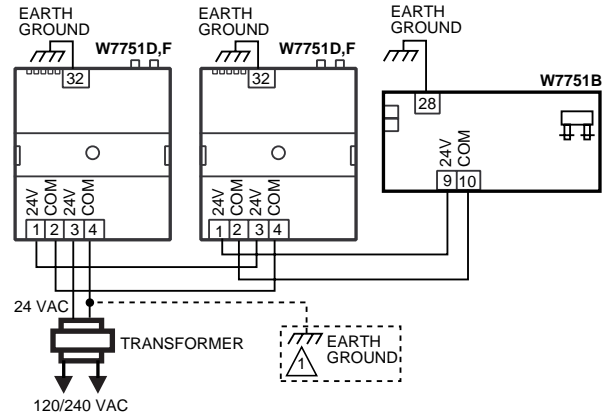

IF THE W7751 CONTROLLER IS USED IN UL 1995 EQUIPMENT AND THE PRIMARY POWER IS MORE THAN 150 VOLTS, GROUND ONE SIDE OF TRANSFORMER SECONDARY.

M12606

Fig. 7. Power wiring for multiple controllers.

Notes on Communications Wiring:

- All field wiring must conform to local codes and ordinances (or as specified on the installation drawings).
- Approved cable types for E-Bus communications wiring are Level IV 22 AWG (0.34 mm²) plenum or non-plenum rated unshielded, twisted pair, solid conductor wire. For nonplenum areas, U.S. part AK3781 (one pair) or U.S. part AK3782 (two pair) can be used. In plenum areas, U.S. part AK3791 (one pair) or U.S. part AK3792 (two pair) can be used. See Table 11 for part numbers in System Engineering form, 74-2949.
- Unswitched 24 Vac power wiring can be run in the same conduit as the E-Bus cable.
- Do not bundle output wires with sensor, digital input or communications E-Bus wires.
- Do not use different wire types or gauges on the same E-Bus segment. The step change in line impedance characteristics would cause unpredictable reflections on the E-Bus. When using different types is unavoidable, use a Q7751A Router at the junction.
- In noisy (high EMI) environments, avoid wire runs parallel to noisy power cables, motor control centers, or lines containing lighting dimmer switches, and keep at least 3 in. (76 mm) of separation between noisy lines and the E-Bus cable.
- Make sure that neither of the E-Bus wires is grounded.

NOTE: If a 209541B Termination Module is required at the VAV controller, connect two of the three termination module wires to the E-Bus terminals. Selecting the appropriate two wires depends on the E-Bus network topology. Refer to the *E-Bus Wiring Guidelines* form, 74-2865, and the *Excel 10 FTT Termination Module Installation Instructions*, form 95-7554. For example, using a doubly terminated daisy-chained bus topology, if controllers are on either end of an E-Bus wire run, mount the termination module on the appropriate terminals as shown in Fig. 8.

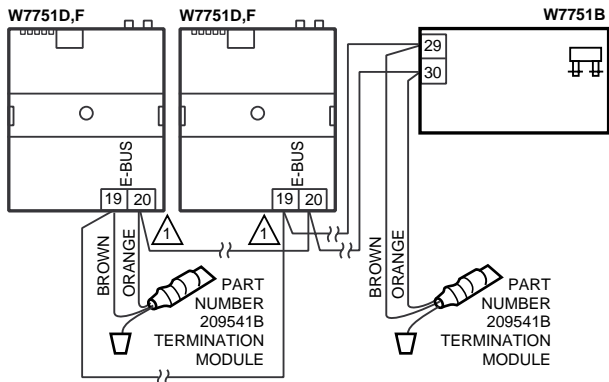

⚠ TO ASSURE PROPER ELECTRICAL CONTACT, WIRES MUST BE TWISTED TOGETHER BEFORE INSERTION INTO THE TERMINAL BLOCK. M12607

Fig. 8. Termination modules (place a wire nut on each remaining wire that is not connected to a controller or device).

Wire to the terminal blocks as follows:

1. Strip 3/16 in. (5 mm) insulation from the conductor.
2. Insert the wire in the required terminal location and tighten the screw to complete the termination.
3. If two or more wires are being inserted into one terminal location, first strip the wires to 1/2 in. (13 mm), then twist the wires together and cut to 3/16 in. (5 mm) before inserting them.

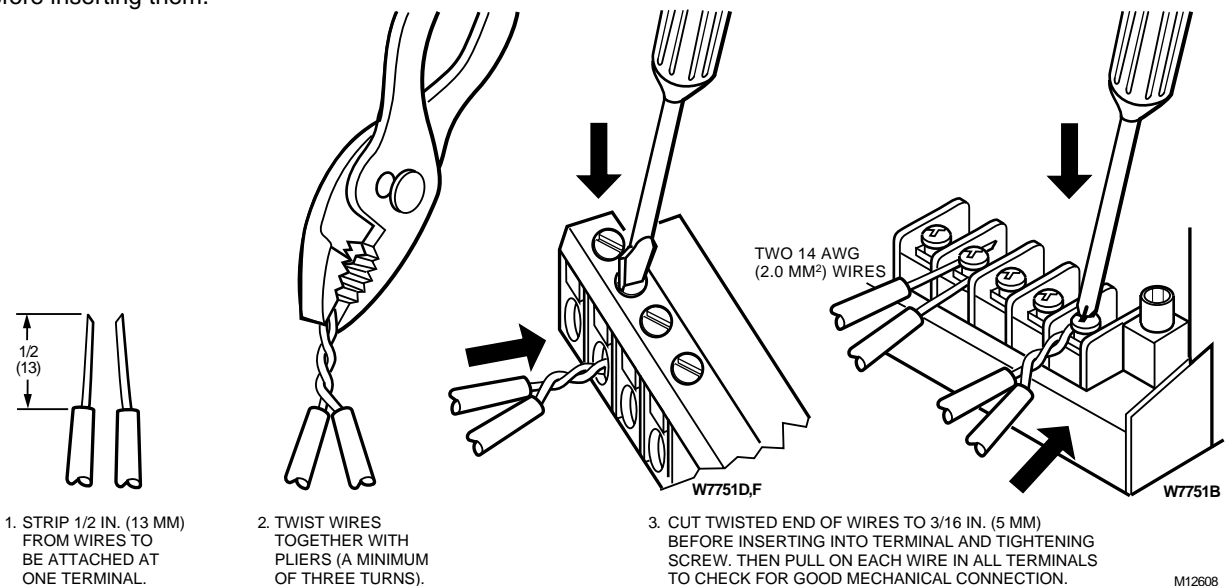

Fig. 9. Attaching two or more wires at terminal blocks.

IMPORTANT

Screw type terminal blocks on the W7751D,F are designed to accept no more than one 14 AWG (2.0 mm²) conductor. Multiple wires that are 14 AWG (2.0 mm²) can be connected with a wire nut. Include a pigtail with this wire group and attach the pigtail to the individual terminal block.

NOTE: When two or more wires are to be attached to the same terminal, other than 14 AWG (2.0 mm²), be sure to twist them together. Deviation from this rule can result in improper electrical contact. See Fig. 9.

Wire to quarter inch quick connects as follows:

1. Strip 3/16 in. (5 mm) insulation from the conductor(s).
2. Select appropriate size quarter-inch (6.35 mm) quick connect that will accept the number of wire(s) needed for terminal.
3. Crimp the quarter-inch (6.35 mm) quick connect and attach it to the appropriate terminal location.

Wiring Details

Fig. 11 and 17 illustrate the terminal arrangement on the W7751B and W7751D,F Controllers. Fig. 11 through 16 provide detailed wiring diagrams for the W7751B Controller, and Fig. 17 through 22 provide detailed wiring diagrams for the W7751D,F Controllers. Refer to job drawings for specific installation wiring diagrams.

The W7751B VAV Controller must have two complete loops of the wires coming from the T7770 Wall Modules that pass through the split ferrite cores (Fair-Rite® 044316451 or equivalent Honeywell part 229997CB). The W7751B VAV Controller and the split ferrite cores must also be in a metal enclosure to ensure compliance with CE requirements. See Fig. 10.

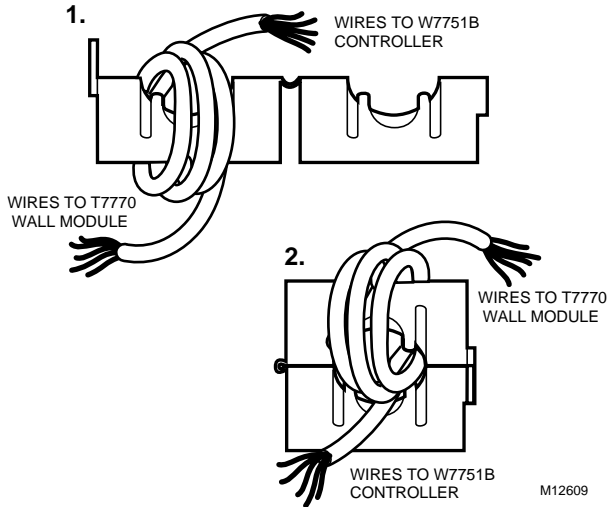
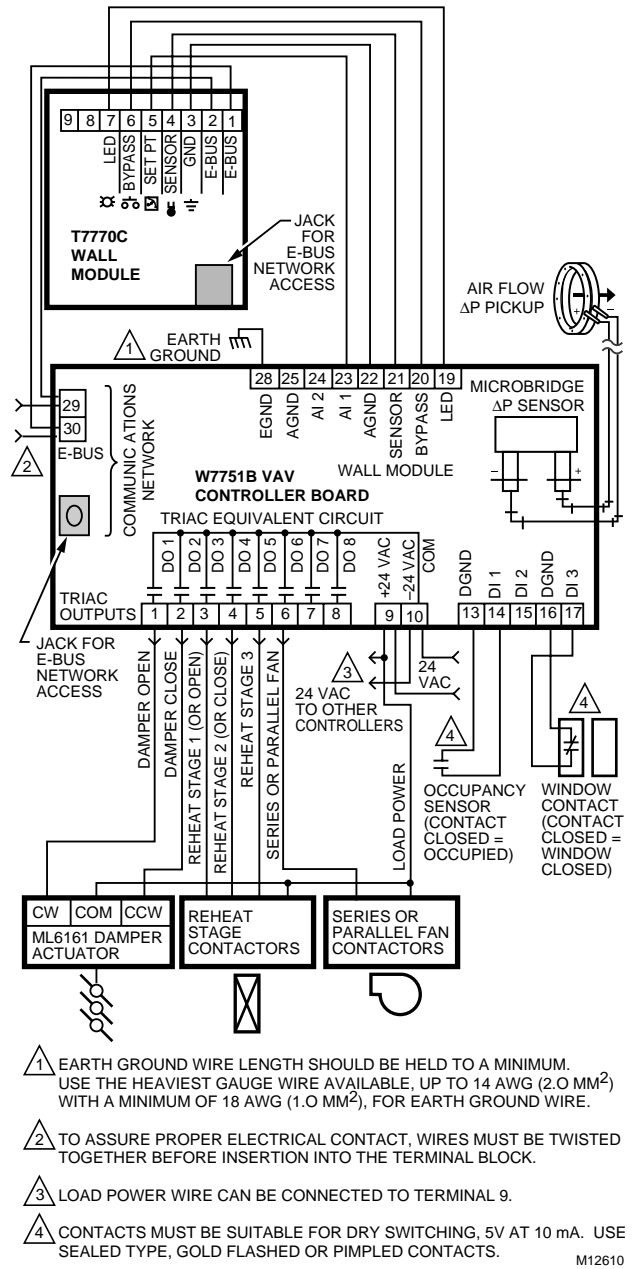
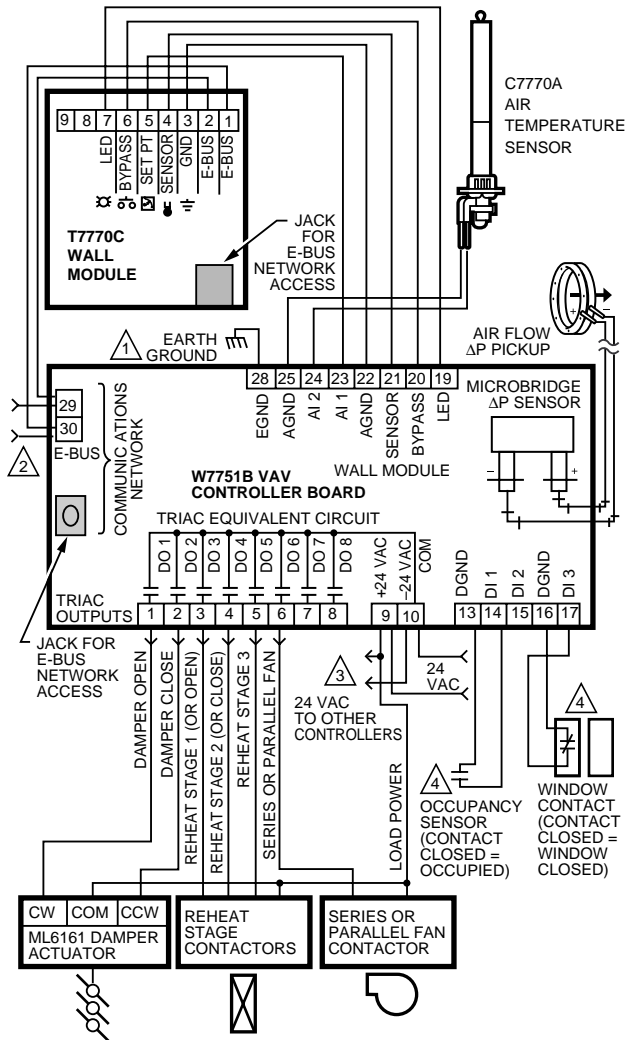

Fig. 10. Ferrite core for T7770 Wall Module wires going to a W7751B VAV Controller.



- ⚠️ 1 EARTH GROUND WIRE LENGTH SHOULD BE HELD TO A MINIMUM. USE THE HEAVIEST GAUGE WIRE AVAILABLE, UP TO 14 AWG (2.0 MM²) WITH A MINIMUM OF 18 AWG (1.0 MM²), FOR EARTH GROUND WIRE.
- ⚠️ 2 TO ASSURE PROPER ELECTRICAL CONTACT, WIRES MUST BE TWISTED TOGETHER BEFORE INSERTION INTO THE TERMINAL BLOCK.
- ⚠️ 3 LOAD POWER WIRE CAN BE CONNECTED TO TERMINAL 9.
- ⚠️ 4 CONTACTS MUST BE SUITABLE FOR DRY SWITCHING, 5V AT 10 mA. USE SEALED TYPE, GOLD FLASHED OR PIMPLED CONTACTS.

Fig. 11. Typical W7751B application wiring diagram. (For notes 2 and 3, refer to Fig. 9.)



- 1 EARTH GROUND WIRE LENGTH SHOULD BE HELD TO A MINIMUM. USE THE HEAVIEST GAUGE WIRE AVAILABLE, UP TO 14 AWG (2.0 MM²) WITH A MINIMUM OF 18 AWG (1.0 MM²), FOR EARTH GROUND WIRE.
- 2 TO ASSURE PROPER ELECTRICAL CONTACT, WIRES MUST BE TWISTED TOGETHER BEFORE INSERTION INTO THE TERMINAL BLOCK.
- 3 LOAD POWER WIRE CAN BE CONNECTED TO TERMINAL 9.
- 4 CONTACTS MUST BE SUITABLE FOR DRY SWITCHING, 5V AT 10 mA. USE SEALED TYPE, GOLD FLASHED OR PIMPLED CONTACTS.

Fig. 12. Typical W7751B application wiring diagram using the T7770C Wall Module and a C7770A Air Temperature Sensor. (For notes 2 and 3, refer to Fig. 9.)

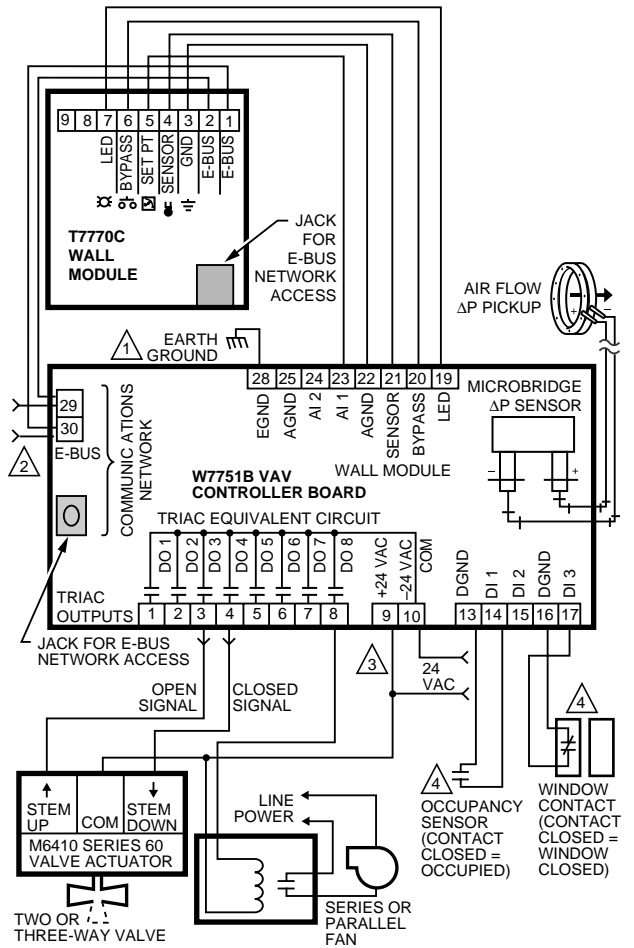

- 1 EARTH GROUND WIRE LENGTH SHOULD BE HELD TO A MINIMUM. USE THE HEAVIEST GAUGE WIRE AVAILABLE, UP TO 14 AWG (2.0 MM²) WITH A MINIMUM OF 18 AWG (1.0 MM²), FOR EARTH GROUND WIRE.
- 2 TO ASSURE PROPER ELECTRICAL CONTACT, WIRES MUST BE TWISTED TOGETHER BEFORE INSERTION INTO THE TERMINAL BLOCK.
- 3 LOAD POWER WIRE CAN BE CONNECTED TO TERMINAL 9.
- 4 CONTACTS MUST BE SUITABLE FOR DRY SWITCHING, 5V AT 10 mA. USE SEALED TYPE, GOLD FLASHED OR PIMPLED CONTACTS.

Fig. 13. Typical W7751B modulating reheat valve and a series/parallel fan wiring diagram. (For notes 2 and 3, refer to Fig. 9.)

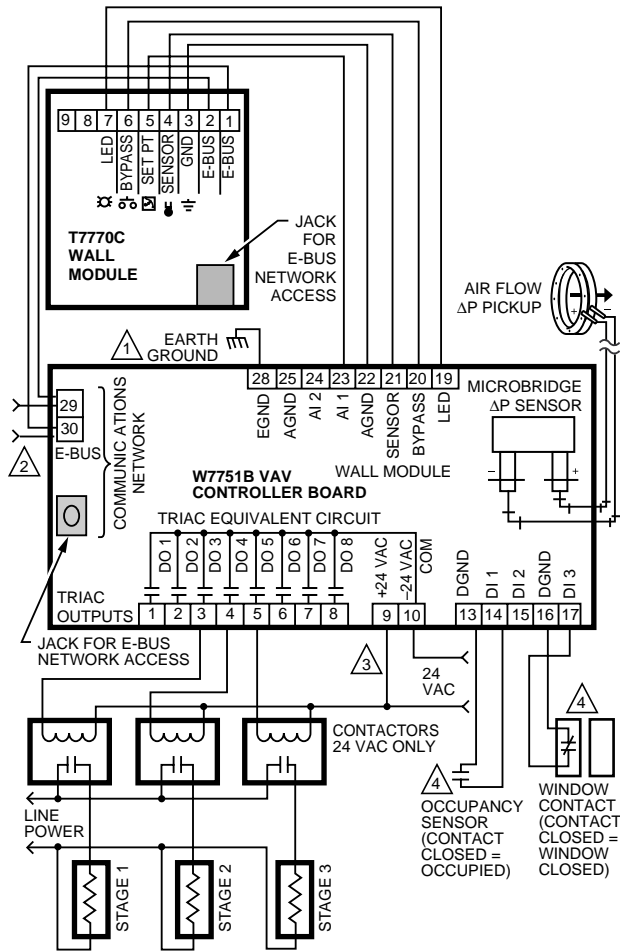

- 1 EARTH GROUND WIRE LENGTH SHOULD BE HELD TO A MINIMUM. USE THE HEAVIEST GAUGE WIRE AVAILABLE, UP TO 14 AWG (2.0 MM²) WITH A MINIMUM OF 18 AWG (1.0 MM²), FOR EARTH GROUND WIRE.
- 2 TO ASSURE PROPER ELECTRICAL CONTACT, WIRES MUST BE TWISTED TOGETHER BEFORE INSERTION INTO THE TERMINAL BLOCK.
- 3 LOAD POWER WIRE CAN BE CONNECTED TO TERMINAL 9.
- 4 CONTACTS MUST BE SUITABLE FOR DRY SWITCHING, 5V AT 10 mA. USE SEALED TYPE, GOLD FLASHED OR PIMPLED CONTACTS.

Fig. 14. Typical W7751B staged reheat wiring diagram. (For notes 2 and 3, refer to Fig. 9.)

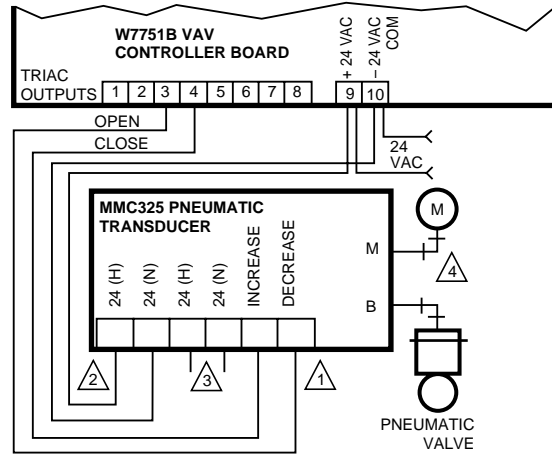

- 1 REVERSE WIRES (INCREASE/DECREASE) TO REVERSE ACTION (DIRECT/REVERSE).
- 2 MAKE SURE ALL TRANSFORMER/POWER WIRING IS AS SHOWN: REVERSING TERMINATIONS WILL RESULT IN EQUIPMENT MALFUNCTION.
- 3 OPTIONAL 24 VAC WIRING TO NEXT CONTROLLER.
- 4 USE 1/4 IN (6 MM) PNEUMATIC TUBING. MINIMUM BRANCH LINE MUST BE 6 FT. (1.8M) OR LONGER.

Fig. 15. Typical W7751B pneumatic transducer wiring diagram. (For notes 2 and 3, refer to Fig. 9.)

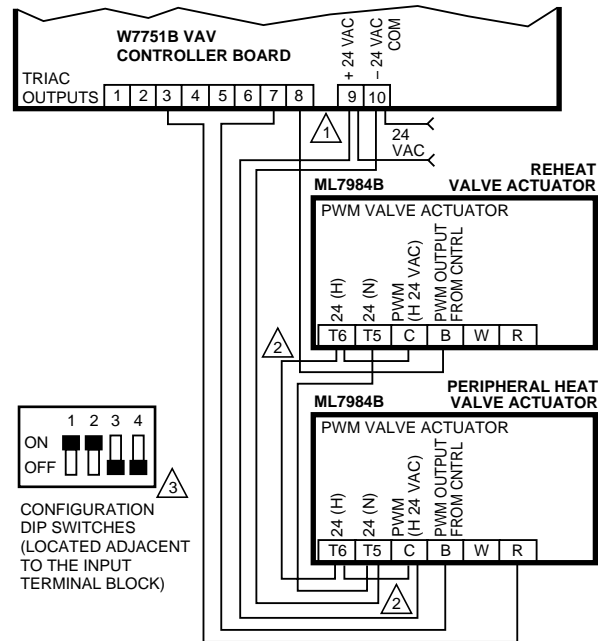

- 1 MAKE SURE ALL TRANSFORMER/POWER WIRING IS AS SHOWN: REVERSING TERMINATIONS WILL RESULT IN EQUIPMENT MALFUNCTION.
- 2 TO ASSURE PROPER ELECTRICAL CONTACT, WIRES MUST BE TWISTED TOGETHER BEFORE INSERTION.
- 3 TURN POWER OFF BEFORE SETTING THE DIP SWITCHES.

Fig. 16. Typical W7751B PWM reheat and PWM peripheral heat valve actuator wiring diagram. (For notes 2 and 3, refer to Fig. 9.)

NOTE: Make sure to set the Configuration DIP Switch as shown in Fig. 16. Switches 1 through 3 set the timing of the ML7984B valve actuator to match the W7751B outputs (0.1 sec. Min. with a max. time of 25.6 sec.). Switch 4 determines the action of the actuator (Off = Direct Acting, On = Reverse Acting).

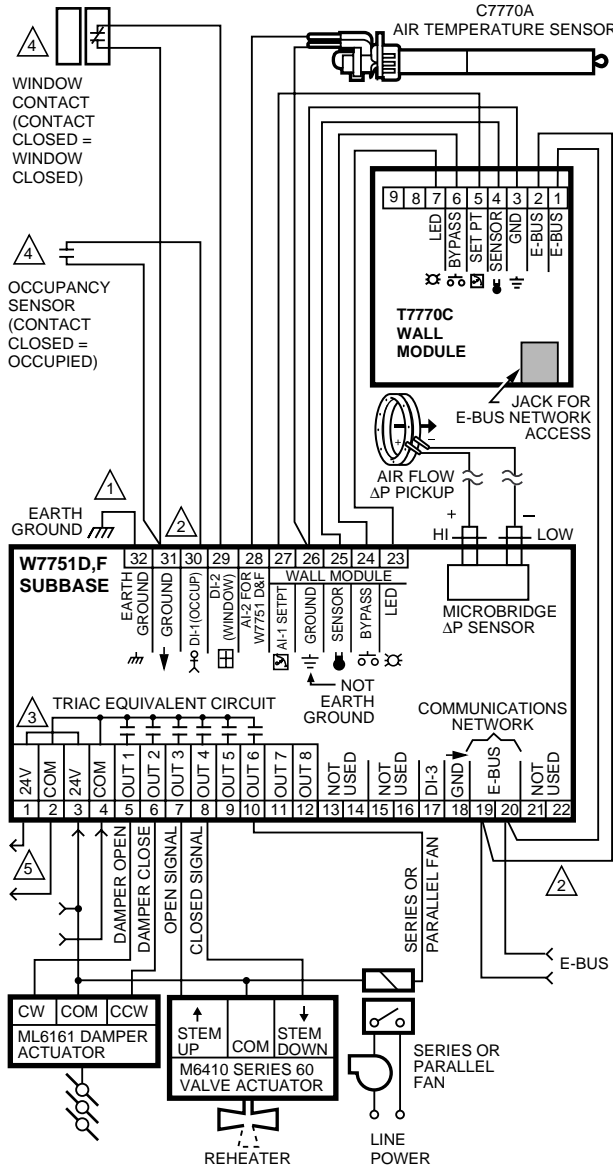

- 1 EARTH GROUND WIRE LENGTH SHOULD BE HELD TO A MINIMUM. USE THE HEAVIEST GAUGE WIRE AVAILABLE, UP TO 14 AWG (2.0 MM²) WITH A MINIMUM OF 18 AWG (1.0 MM²), FOR EARTH GROUND WIRE.
- 2 TO ASSURE PROPER ELECTRICAL CONTACT, WIRES MUST BE TWISTED TOGETHER BEFORE INSERTION INTO THE TERMINAL BLOCK.
- 3 TERMINALS 1 AND 3 LOAD POWER.
- 4 CONTACTS MUST BE SUITABLE FOR DRY SWITCHING, 5V AT 10 mA. USE SEALED TYPE, GOLD FLASHED OR PIMPLED CONTACTS.
- 5 24 VAC TO OTHER CONTROLLERS.

M12616

Fig. 17. Typical W7751D,F VAV box wiring diagram using the T7770C Wall Module and a C7770A Air Temperature Sensor. (For note 2, refer to Fig. 9.)

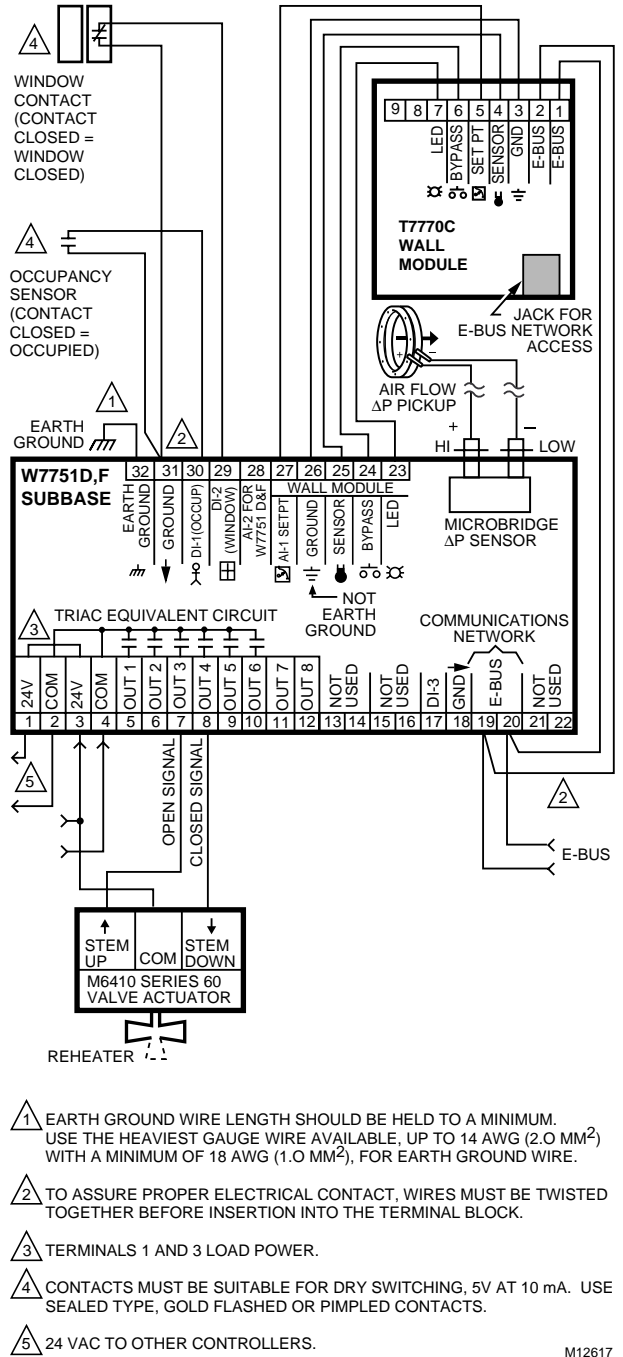

- 1 EARTH GROUND WIRE LENGTH SHOULD BE HELD TO A MINIMUM. USE THE HEAVIEST GAUGE WIRE AVAILABLE, UP TO 14 AWG (2.0 MM²) WITH A MINIMUM OF 18 AWG (1.0 MM²), FOR EARTH GROUND WIRE.
- 2 TO ASSURE PROPER ELECTRICAL CONTACT, WIRES MUST BE TWISTED TOGETHER BEFORE INSERTION INTO THE TERMINAL BLOCK.
- 3 TERMINALS 1 AND 3 LOAD POWER.
- 4 CONTACTS MUST BE SUITABLE FOR DRY SWITCHING, 5V AT 10 mA. USE SEALED TYPE, GOLD FLASHED OR PIMPLED CONTACTS.
- 5 24 VAC TO OTHER CONTROLLERS.

M12617

Fig. 18. W7751D,F modulating reheat valve wiring diagram. (For note 2, refer to Fig. 9.)

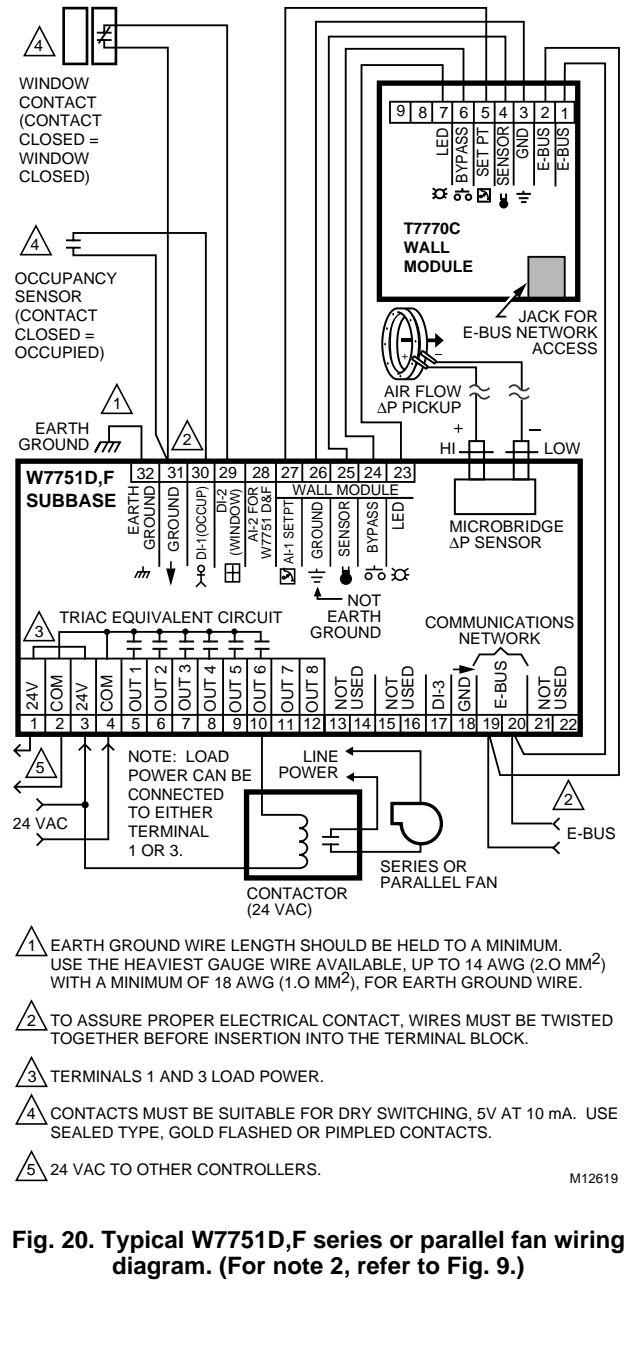
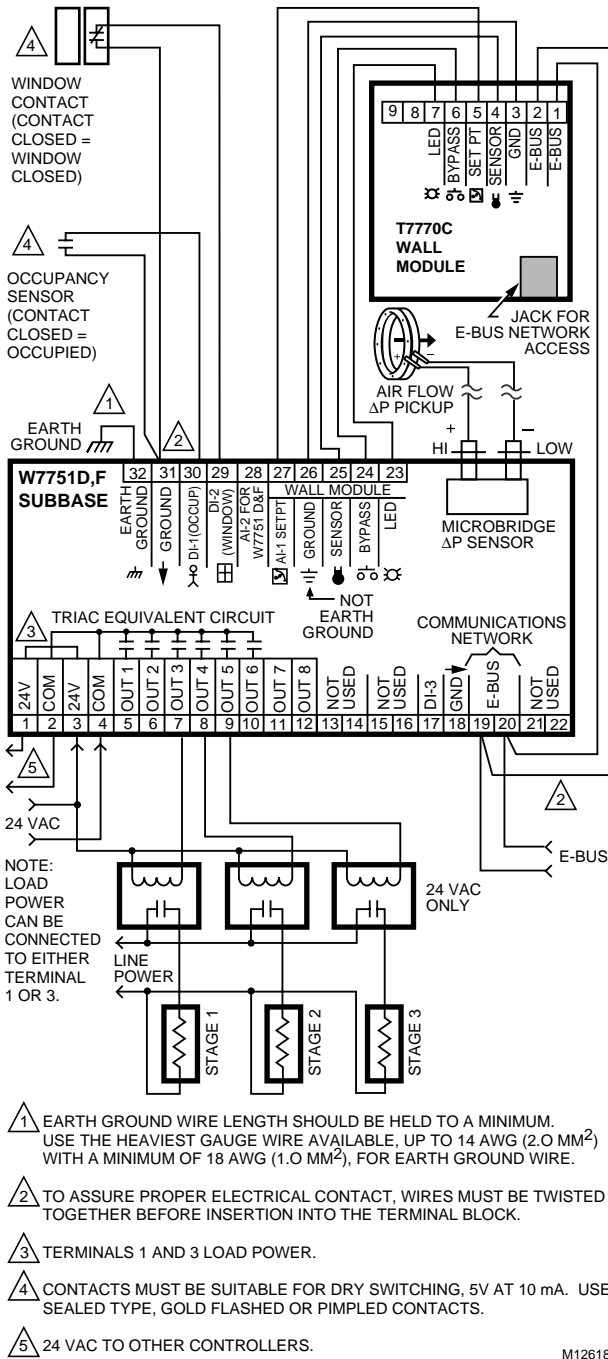

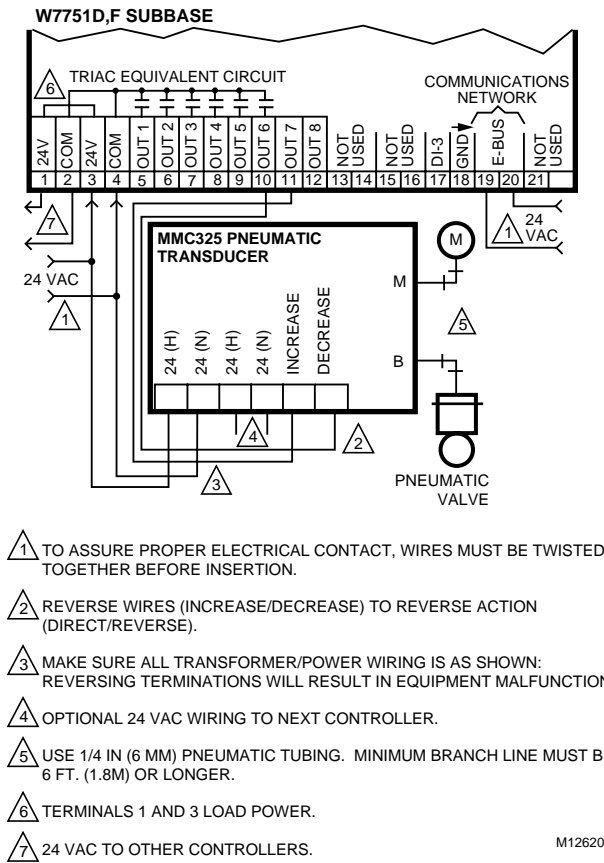

Fig. 21. Typical W7751D,F pneumatic transducer wiring diagram. (For notes 2 and 3, refer to Fig. 9.)

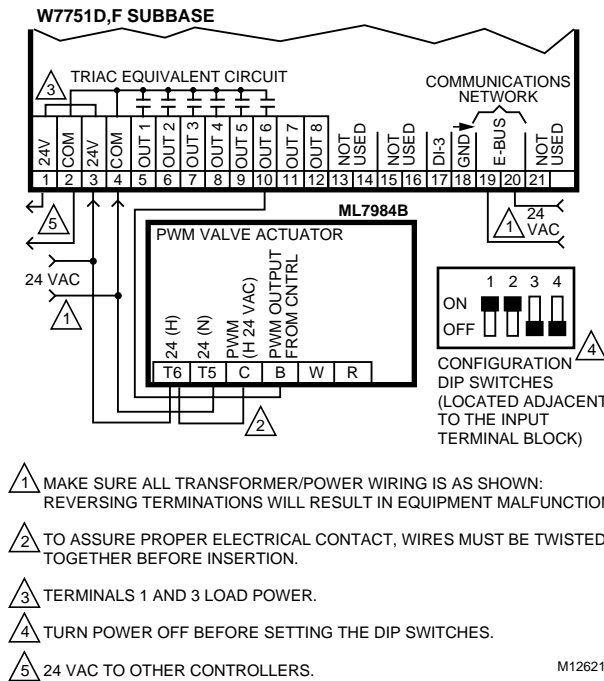

Fig. 22. Typical W7751D,F PWM reheat and PWM peripheral heat valve actuator wiring diagram. (For notes 2 and 3, refer to Fig. 9.)

NOTE: Make sure to set the Configuration DIP Switch as shown in Fig. 22. Switches 1 through 3 set the timing of the ML7984B valve actuator to match the W7751D,F outputs (0.1 sec. Min. with a max. time of 25.6 sec.). Switch 4 determines the action of the actuator (Off = Direct Acting, On = Reverse Acting).

CHECKOUT

W7751B,D,F Checkout

Step 1. Wiring Connections

Inspect all wiring connections at the W7751B,D,F and the T7770 terminals, and verify compliance as specified on installation wiring diagrams. If any wiring changes are required, *first* be sure to remove power from the controller *before* starting work. Pay particular attention to:

- 24 Vac power connections. Verify multiple controllers being powered by the same transformer are wired with the transformer secondary connected to the same input terminal numbers on each W7751. See Fig. 7. (Controller configurations are not necessarily limited to three devices, but the total power draw including accessories cannot exceed 100 VA (U.S. only) when powered by the same transformer. See System Engineering form, 74-2949 for power wiring recommendations.)
- Controller wiring. Be sure that each controller is wired (28 on the W7751B, 32 on the W7751D,F and terminal 3 on the W7751H) to a verified earth ground using a wire run as short as possible with the heaviest gauge wire available, up to 14 AWG (2.0 mm²) with a minimum of 18 AWG (1.0 mm²) for each controller in the group. (See Fig. 11 or 17.)
- Verify Triac wiring to external devices uses the proper load power/24 Vac Hot terminal (see Fig. 11 through 22).

Verify Termination Module Placement

The installation wiring diagrams should indicate the locations for placement of 209541B Termination Modules on each E-Bus segment (refer to the E-Bus Wiring Guidelines form, 74-2865, or see the rules described in the Excel 10 System Engineering form, 74-2949). The FTT E-Bus Termination Module (209541B) may be attached to the network at a controller node, a wall module, or at a wiring junction. The module has 3 lead wires (refer to Fig. 8), 2 of which are attached to the network (place a wire nut on the unused wire), depending on which type of network termination is required. If the E-Bus segment is singly terminated use the brown and orange wires, if the E-Bus segment uses doubly terminated daisy-chain use the brown and yellow wires.

Correct placement of the termination modules is required for proper E-Bus communications.

Step 2. Startup

Broadcasting the Service Message

The Service Message allows a device on the E-Bus to be positively identified. The Service Message contains the controller ID number and, therefore, can be used to confirm the physical location of a particular Excel 10 VAV Controller in a building.

When an *Assign ID* command is issued from the CARE commissioning tool (E-Vision), the node goes into the SERVICE_MESSAGE mode for five minutes. In the SERVICE_MESSAGE mode, pressing the occupancy override button on a wall module causes the Service Message to be broadcast on the network. All other functions are normal in the SERVICE_MESSAGE mode. If an Excel 10 VAV Controller does not have an override button connected, it can still broadcast the Service Message on the network by temporarily shorting the controller Bypass Input terminal to the Sensor Ground (on the W7751B short terminals 20 and 22 or on the W7751D,F short terminals 24 and 26).

Alarms

The CARE commissioning tool (E-Vision) is used to perform the ID Assignment task (see E-Vision User Guide form, 74-2588). Once the ID Assignment and commissioning has been done, check the controller status LED to determine if there are any alarms.

W7751 Controller Status LEDs

The LED on the front of a W7751B,D,F Controller, provides a visual indication of the status of the device. When the W7751B,D,F receives power, the LED appears in one of the following allowable states:

1. Off—no power to the processor.
2. Continuous on—processor is in initialized state.
3. Slow blink—controlling, normal state.
4. Fast blink—when the Excel 10 VAV Controller has an alarm condition.

When an Excel 10 has an alarm condition, it reports it to the central node on the E-Bus (typically, the Excel 10 Zone Manager). Also, the Excel 10 VAV Controller variables (*AlarmLogX*, where *X* is 1 through 5) that store the last five alarms to occur in the controller, are available. These points can be viewed through XBS, XI584 or E-Vision. Refer to the VAV System Engineering form, 74-2949, Table 12 for a description of the Excel 10 Alarms.

NOTE: The node can be reset by switching the node to MANUAL and then to the normal operating mode (using DestManMode).

T7770C or D Wall Module Override LED

The remote override LED, located on either the T7770C or T7770D Wall Module will display the Manual Override mode of the controller. The modes are:

1. LED = Off. No override active.
2. LED = Continuously On. Bypass mode (timed Occupied override).
3. LED = One flash per second. Continuous Unoccupied override.
4. LED = Two flashes per second. Remote only, continuous Occupied override.

Step 3. I/O Tests

The controller must be configured using the Excel 10 E-Vision PC configuration tool. Once this is done, the W7751B,D,F can be commanded to MANUAL mode, and each output and input can be exercised/viewed to verify proper wiring connections and equipment operation. See the Excel 10 E-Vision Users Guide form, 74-2588, for details on configuring W7751B,D,F Controllers.

Step 4. Verify Sequences of Operation

For the detailed descriptions of the sequences of operation, see the Excel 10 VAV System Engineering form, 74-2949.

Home and Building Control
Honeywell Inc.
Honeywell Plaza
P.O. Box 524
Minneapolis, MN 55408-0524

Home and Building Control
Honeywell Limited-Honeywell Limitee
155 Gordon Baker Road
North York, Ontario
M2H 3N7

Home and Building Control Products
Honeywell AG
Böblinger Straße 17
D-71101 Schönaich
Phone (49-7031) 637-01
Fax (49-7031) 637-493

Honeywell

Helping You Control Your World®

