

## Excel 10

### W7763C,D,E CHILLED CEILING CONTROLLERS

#### SPECIFICATION DATA



#### GENERAL

The W7763C, D and E Controllers are Chilled Ceiling Controllers belonging to the Excel 10 product line. They cover a wide range of control applications, including radiators, induction units, and fan coil units with manual fan switching, chilled ceiling, and chilled beam and are suitable for either wall mounting or unit mounting. The controllers can operate as stand-alone units or be networked using the standard Echelon LONWORKS bus. Interfaces are provided for a wide range of actuator types. Heating systems can be water or electric, and cooling systems can be chilled water supply or compressors. Extensive timing and interlock features make the W7763 especially suitable for systems using electric heat and compressors.

#### FEATURES

- LONMARK® HVAC profile #8020.
- Stand-alone operation or on high-speed 78 kilobit Echelon® LONWORKS® network.
- Uses Echelon LonTalk® protocol.
- FTT10A Transceiver.
- Direct connection of thermal actuators.
- Factory-configured default parameters.
- Wide range of supported valves and actuators.
- Available with setpoint knob for wall mounting.
- Built-in E-Bus jack for easy network access.
- LonWorks service pin and LED accessible without disassembly.

#### DESCRIPTION

The W7763C, D and E are LONMARK-compliant Chilled Ceiling Controllers in the Excel 10 family product line. These controllers provide room temperature control using different heating and cooling sequences. The controller is provided with default configuration settings from the factory and is fully operable on installation. Using standard Echelon configuration tools, the controller can be configured with job-specific settings. A variety of optional wall modules interface with the Chilled Ceiling Controllers and provide any or all of the following: setpoint adjustment, and an occupancy bypass button. All wall modules include a space temperature sensor; however, a remote C7068A return air sensor can also be used.

**Table 1. Supported output types**

output	options
heating	floating, thermal, PWM, on/off, multi-stage electric.
cooling	floating, thermal, PWM, on/off, multi-stage compressor.

**Table 2. Chilled Ceiling Controller models**

model	inputs	control outputs	setpoint knob	internal sensor	bypass button
W7763C	3	2	X	X	X
W7763D	4	2	X	--	--
W7763E	4	2	--	--	--

## Sequences

Heat and cool sequences can be selected to be active or not active, giving a total of four different sequence options:

- Heat only
- Cool only
- Heat/cool changeover
- Heat and cool sequence

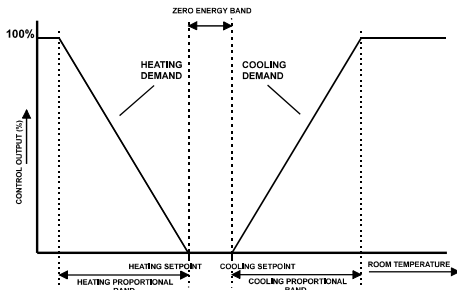

Fig. 1. Operational sequence

## Modes of Operation

The controller has the following modes of operation.

### Occupied Mode

This is the normal operating condition for a room or zone when it is occupied. The controller can be switched into this mode by a network command, by the room occupancy sensor, or by a bypass button on the wall module.

### Standby Mode

The standby mode saves energy by reducing heating or cooling demand during periods where the room is temporarily unoccupied.

### Unoccupied Mode

This mode is used for longer unoccupied periods, such as at night or during weekends and holidays.

### Window Open

If the controller is configured for window open detection, the controller automatically disables heat and cool control until the window is closed again. Frost protection remains active.

### Frost Protection

If the temperature drops below 46°F (8°C), the controller enables the heating circuit as frost protection.

### Fan Fail

When configured with an airflow detector, the controller protects equipment by disabling the system when the fan fails (for fan coil units with manual fan speed control).

### Changeover

The controller operates two-pipe units configured with a changeover input.

### Dewpoint

When configured with a chilled water temperature sensor, the controller will close the cool valve when the chilled water temperature falls below the dewpoint. The dewpoint may be a fixed value or calculated based upon input from a humidity sensor.

## Condensation

When configured with a condensation switch, the controller will close the cool valve when condensation is detected.

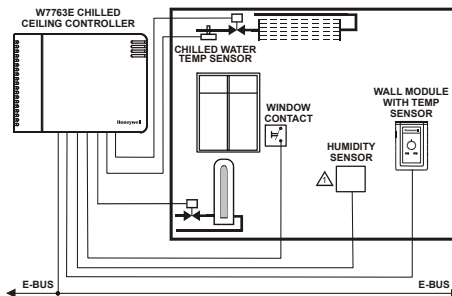

⚠ Digital wall module T7560B is equipped with an internal humidity sensor.

Fig. 2. Typical application

Table 3. Input/output specifications

inputs	function	pin no.	characteristics
digital	window / occupancy / changeover / air-flow / condensation	4	closed $\leq 400$ ohm (1.5 mA), open $\geq 10k$ ohm (4.8 V)
digital <sup>1,2</sup>	override	7	closed $\leq 400$ ohm, open $\geq 3.3K$ ohm
analog	humidity sensor	1	0 ... 10 Vdc
analog	temperature sensor <sup>4</sup>	9,10	20k ohm NTC (25°C)
analog <sup>1</sup>	setpoint adjustment	8	10k ohm
<b>outputs</b>			
digital <sup>1</sup>	override LED	6	0/5 Vdc (I<10 mA)
triac (2 pairs) <sup>3</sup>	heat and cool	14,15 17,18	24 Vac, 250 mA max. continuous, 650 mA max surge ( $\leq 30$ sec)

<sup>1</sup> Wall module connection, only.

<sup>2</sup> Wall modules with fan speed switches must not be used.

<sup>3</sup> See Table 1 for output type options.

<sup>4</sup> If an external temperature sensor is connected, the internal temperature sensor of the W7763C is not used.

## SPECIFICATIONS

### Models

See Table 2 for summary of models. The W7763C and D can be ordered with setpoint adjustment in °C or °F absolute or °C relative.

### Input/Output

See Table 3.

### Power Supply

24 Vac  $\pm 20\%$ , 50/60 Hz.

### Power Consumption

0.5 VA maximum (no load). See Excel 10 Chilled Ceiling Controller System Engineering Guide, form number 74-2990 for transformer sizing information.

### Hardware Design

**Processor:**  
 Neuron 3150<sup>®</sup> running at 5 MHz, with 2 Kbyte of RAM and 0.5 Kbyte of EEPROM on chip.  
**External memory:**  
 EPROM, 64 Kbyte by 8.  
**Communication Interface:**  
 Echelon transceiver FTT10A.  
 Compatible to Echelon Link Power Network.  
 LONWORKS service pin accessible on underside of housing.  
 LONWORKS LED visible through air vents on front of housing.

### Specified Sensing Temperature Range

32° to 158 °F (0° to 70 °C)

### Environmental Ratings

**Operating temperature:**  
 32 ... 122 °F (0 ... 50 °C)  
**Shipping/storage temperature:**  
 -4 ... 158 °F (-20 ... 70 °C)  
**Relative humidity:**  
 5% to 95% noncondensing

### Dimensions

3-3/8 x 4-9/16 x 1-13/16 in. (86 x 116 x 46 mm)

### Communications

The W7763 controllers use Link Power-compatible free topology transceivers (FTT) and LonTalk bus protocol for communications. The LONWORKS Bus is insensitive to polarity, eliminating wiring errors during installation. A 3.5 mm LONWORKS jack is provided on the controllers for easy network access.

The recommended wire size to be used for the LONWORKS is level IV 22 AWG (Belden part number 9D220150) or plenum rated level IV 22 AWG (Belden part number 9H2201504) nonshielded, twisted pair, solid conductor wire.

FTT networks can be in bus, star, loop or any combination of these topologies. See LONWORKS Mechanisms – Interface Description (Product Literature No.: EN0B-0270GE51) for more information including maximum lengths.

### LONMARK Functional Profile

W7763 Chilled Ceiling Controllers support the LONMARK Functional Profile #8020 “Fan Coil Unit Controller”, version 2.0 (see Fig. 3).

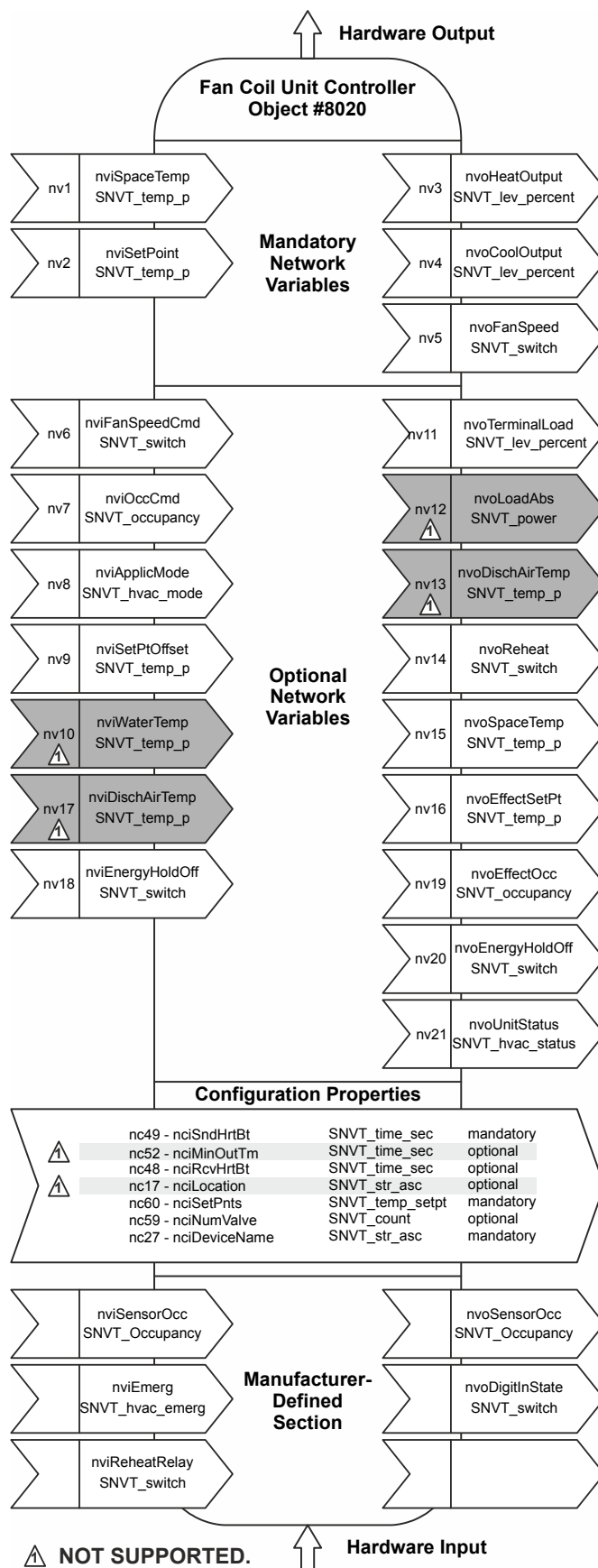

Fig. 3. LONMARK object details

### Mounting Options

W7763 Controllers can be mounted directly on a panel or wall with two screws or it can be mounted with four screws on a standard 60 mm junction box. They can be mounted in any orientation desired – with the exception of the W7763C, which may not be mounted on the ceiling (horizontally).

### Approvals and Standards

CE  
 EN50081-1  
 EN50082-1  
 meets FCC part 15 class B requirements

### Accessories

- Excel 10 T7460 Wall Modules
- Excel 10 T7560 Wall Modules
- Excel 10 T7770 Wall Modules
- XAL Term Termination Module
- C7068A Return Air Sensor (Europe, only)
- VF20A Strap-on Temperature Sensor
- M7410C Small Electric Linear Valve Actuator (Europe, only)
- Z100 Thermoelectric Actuator (Europe, only)
- H7011, H7012 Humidity Sensors
- HKF1, HRF1 Humidity Sensors

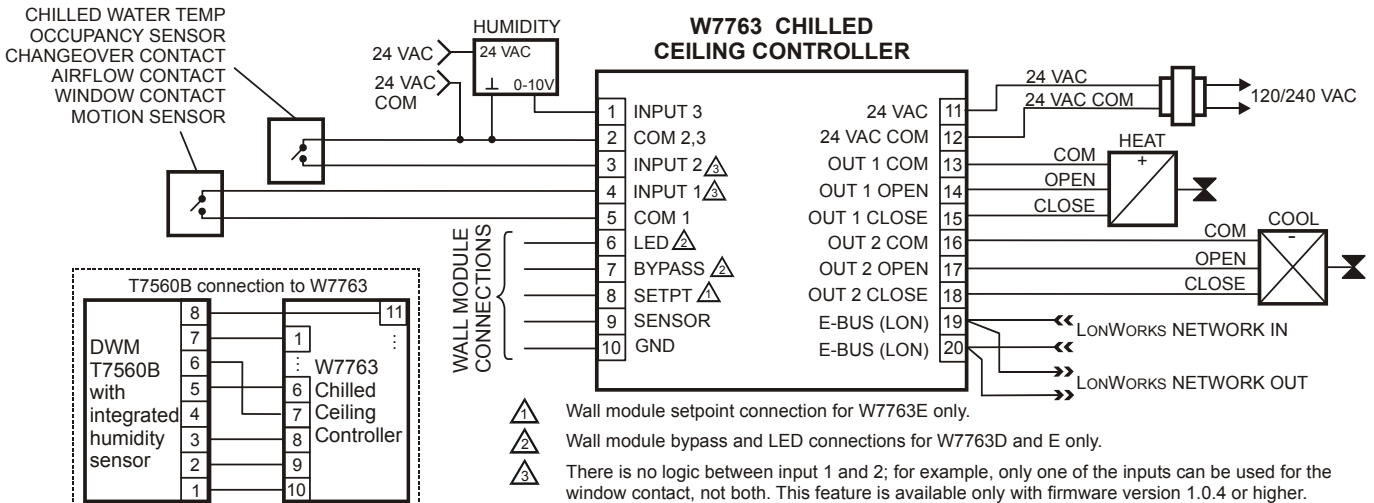

Fig. 4. Input/output details

Table 4. Output assignments for various actuator types

output type	Out 1 terminal			Out 2 terminal		
	13	14	15	16	17	18
Floating	24 Vac	open	close	24 Vac	open	close
1-stage	24 Vac	on/off	—	24 Vac	on/off	—
2-stage	24 Vac	stage 1	stage 2	24 Vac	stage 1	stage 2
3-stage	24 Vac	stage 1	stage 2	24 Vac	stage 1	stage 2
		stage 3			stage 3	
PWM	24 Vac	PWM	—	24 Vac	PWM	—
Thermal	24 Vac	on/off	—	24 Vac	on/off	—



Manufactured for and on behalf of the Environmental and Combustion Controls Division of Honeywell Technologies Sàrl, Rolle, Z.A. La Pièce 16, Switzerland by its Authorized Representative:

#### Automation and Control Solutions

Honeywell GmbH  
 Böblinger Strasse 17  
 71101 Schönaich  
 Germany  
 Phone: (49) 7031 63701  
 Fax: (49) 7031 637493  
<http://ecc.emea.honeywell.com>  
 Subject to change without notice. Printed in Germany